



KOLBENSCHMIDT



PIERBURG



TRW

EngineComponents



turbo by INTEC

KATALOG PRODUKTÓW

CZĘŚCI ZAMIENNE DO
ELEKTROCIĘPŁOWNI I SILNIKÓW GAZOWYCH

TAKING RESPONSIBILITY IN A CHANGING WORLD



RHEINMETALL

WAŻNE WSKAZÓWKI

Wszystkie informacje zawarte w tym katalogu są niewiążące. Nie możemy przyjąć żadnej odpowiedzialności za ich poprawność i kompletność. Informacje o ewentualnych błędach w katalogu są zawsze mile widziane i będą poprawiane w kolejnych wydaniach.

Nazwy, opisy i numery pojazdów lub producentów itp., podobnie jak oryginalne numery części producentów pojazdów i silników, są wymienione tylko w celach porównawczych. Odpowiednie dane nie są określeniami pochodzenia i nie mogą być stosowane w stosunku do osób trzecich. Prosimy uwzględnić to, że zmiany wyposażenia przez producentów pojazdów lub silników bądź zmiany nazw nie mogą zostać wykluczone, dlatego nie odpowiadamy za zastosowanie list porównawczych.

Wyraźnie zastrzegamy sobie prawo do zmiany specyfikacji produktów, materiałów, wyglądu i zakresu dostawy naszych produktów w dowolnym momencie. Ilustracje w katalogu nie są więc wiążące.

Przed montażem należy zawsze sprawdzić, czy zakupiony produkt nadaje się do zamierzonego zastosowania. Z naszych informacji nie można wyprowadzić stwierdzenia o określonym stanie lub przydatności do określonego celu. W szczególności należy zaznaczyć, że produkty oferowane w katalogu nie są przeznaczone do stosowania w statkach powietrznych lub kosmicznych. W przypadku zastosowania w silnikach pozadrogowych (np. morskich, stacjonarnych lub kolejowych) należy pamiętać, że przy tym samym oznaczeniu silnika mogą być stosowane różne części silnika (np. tłoki). W razie potrzeby przed instalacją produktów należy zasięgnąć fachowej porady producenta lub jego autoryzowanego warsztatu. Pragniemy również zwrócić uwagę na to, że montaż musi być zawsze przeprowadzany przez poinstruowany personel specjalistyczny. Ilustracje, rysunki schematyczne i inne informacje mają charakter objaśniający i poglądowy i nie mogą stanowić podstawy do montażu.

Wszelkie powielanie, naśladowanie, rozpowszechnianie lub publiczne odtwarzanie tego katalogu, w całości lub w części, jest dozwolone tylko za naszą uprzednią pisemną zgodą i odpowiednim podaniem źródła. Wraz z publikacją tego katalogu tracą ważność wszystkie poprzednie wydania.

CERTYFIKATY

Firma MS Motorservice International GmbH ma certyfikowany system zarządzania jakością ISO 9001 oraz certyfikowany system zarządzania środowiskiem ISO 14001.



Wykluczenie odpowiedzialności

Nazwy, opisy, numery silników, pojazdów, produktów, producentów itd. są podane tylko do celów porównawczych. Części zawarte w katalogu są częściami zamiennymi do wymienionych zastosowań.

 ZAWARTOŚĆ KATALOGU
 ZNAJDUJE SIĘ RÓWNIEŻ
 W NASZYM KATALOGU
 INTERNETOWYM, W NASZEJ
 APLIKACJI I NA TECALLIANCE.

Dalsze informacje:
catalog.ms-motorservice.com
[motorservice.app](https://play.google.com/store/apps/details?id=com.motorservice)



TecDoc®
 DATA SUPPLIER

SPIS TREŚCI	STRONA
Ważne wskazówki	2
Zarządzanie jakością	2
Części silnikowe do elektrociepłowni i silników gazowych	4
Tłoki bez wgłębienia – artykuły i wskazówki dotyczące obróbki	6
Pierścienie gniazd zaworów – zalecenia dotyczące stosowania	8
Pierścienie gniazd zaworów – instrukcja montażu	9
Pierścienie gniazd zaworów – artykuły i wymiary	10
Głowice cylindrów do silników gazowych	11
Tuleje wałów – instrukcja montażu	12
Tuleje wałów – artykuły i wymiary	14
1. GAMA PRODUKTÓW	18
2. LISTA PORÓWNAWCZA	77
Transfer wiedzy – wiedza fachowa od eksperta	90
Postępowanie w przypadku roszczeń gwarancyjnych	92
Postępowanie w przypadku reklamacji nowych części	93
Warunki sprzedaży i dostaw	94

GRUPA MOTORSERVICE

JAKOŚĆ I SERWIS Z JEDNEJ RĘKI

Grupa Motorservice to organizacja zajmująca się dystrybucją w ramach międzynarodowej działalności firmy Rheinmetall na rynku wtórnym. Jest ona czołowym dostawcą podzespołów silników na niezależnym rynku części zamiennych. Pod markami premium Kolbenschmidt, Pierburg, TRW Engine Components oraz markami BF i Turbo by Intec grupa Motorservice oferuje dealerom i warsztatom szeroki i bogaty asortyment najwyższej jakości części.

RHEINMETALL

INNOWACYJNE TECHNOLOGIE W DZIEDZINIE MOBILNOŚCI

Międzynarodowy dostawca części motoryzacyjnych Rheinmetall zajmuje czołowe pozycje na poszczególnych rynkach dzięki kompetencjom w zakresie układów doprowadzania powietrza, redukcji substancji szkodliwych oraz pomp, a także projektowania, produkcji i dostawy części zamiennych do tłoków, bloków silnika oraz łożysk ślizgowych.

Projektowanie produktów przebiega w ścisłej współpracy z renomowanymi producentami samochodów.



CZĘŚCI SILNIKOWE DO ELEKTROCIĘPŁOWNI I SILNIKÓW GAZOWYCH

PRODUKTY OD EKSPERTÓW

ASORTYMENT DO ELEKTROCIĘPŁOWNI I SILNIKÓW GAZOWYCH

Części silnikowe dla wszystkich rodzajów gazu, zastosowań i producentów

- Głowice cylindra: prowadnica zaworów smarowana olejem / niesmarowana (Ex)
- Tłoki, tuleje cylindrowe, zestawy: tłoki z dostosowaną kompresją, tłoki bez wgłębienia do swobodnej konfiguracji denka tłoka, tuleje cylindrowe z pierścieniem ogniowym
- Pierścienie tłokowe: na życzenie z powłoką DC
- Łożysko ślizgowe: łożysko metalizowane metodą napyłania katodowego 360 stopni
- Zawory: z opancerzeniem gniazda, azotowanie plazmowe
- Prowadnice zaworów: chłodzone olejem, ze smarowaniem olejem
- Gniazda zaworowe: Stellite, Tribaloy
- Korbowody, skrzynia korbowa i inne produkty

WSKAZÓWKA

W przypadku niektórych producentów lub serii silników produkty muszą być wybierane za pomocą numeru silnika w celu dokładnego przypisania.

PRODUCENT

- Doosan
- Energie 2G
- Liebherr
- MAN

- Mitsubishi
- MTU
- Scania
- więcej na życzenie

ZASTOSOWANIA

- Elektrociepłownie
- Silniki stacjonarne
- Silniki przemysłowe
- Maszyny rolnicze
- Maszyny leśne
- Maszyny budowlane

RODZAJE GAZU

- Biogaz
- Gaz drzewny
- Gaz ziemny
- Gaz kopalniany
- Gaz gnilny



INDYWIDUALNE ROZWIĄZANIA

Części specjalne od specjalistów

Wytwarzamy produkty na zamówienie i części specjalne, które nie są dostępne w standardzie, aby spełnić wymagania naszych klientów.

Informacja dotyczące zamawiania

Na życzenie można otrzymać ofertę na produkt wykonany na zamówienie. W tym celu prosimy o załączenie rysunku lub próbki części i podanie jak najdokładniejszych informacji o typie silnika, numerach części, wymiarach i wymaganej ilości.

Części specjalne

- **Tłoki** – minimalne zamówienie: od 300 sztuk
- **Zawory** – minimalne zamówienie: od 300 sztuk
- **Prowadnice zaworów** – minimalne zamówienie: od 100 sztuk
- **Gniazda zaworowe** – minimalne zamówienie: od 500 sztuk

Półfabrykaty: tłoki bez wgłębienia

Do indywidualnej obróbki końcowej przez specjalistyczną firmę, tłoki bez wgłębienia są dostępne na życzenie.



TŁOKI BEZ WGŁĘBIENIA — DOPASOWANE DO SILNIKÓW GAZOWYCH

Silniki gazowe wymagają tłoków dostosowanych do procesu spalania. W przypadku specjalnych wymagań standardowe tłoki są czasami niedostępne.

W Motorservice dostępne są tłoki gazowe bez wgłębienia marki Kolbenschmidt. W przypadku tych tłoków konfiguracja denka tłoka może być dowolnie zaprojektowana. Denko tłoka może być zatem obrabiane dokładnie według wymagań klienta.

WSKAZÓWKA

Tłoka nie wolno montować bez obróbki denka tłoka. W razie potrzeby będziemy obrabiać tłoki gazowe zgodnie z rysunkiem lub próbką zgodnie z wymaganiami i specyfikacjami klienta. Nasz zespół ds. sprzedaży z przyjemnością przedstawi wycenę przetwarzania.

Nr art.:	Silnik	Konstrukcja tłoka	Gniazdo korbowodu	dopasowane do
40 822 600	E2676xxxxx	Z kanałem chłodzącym	Korbowód trapezowy	MAN
41 495 600	E2876xxxxx	Bez kanału chłodzącego		
42 136 600	E083xxxxx			
41 499 600	E2842xxxxx E2848xxxxx		Korbowód równoległy	
42 139 600	MTU 400 MDE B/E 30xx	Bez kanału chłodzącego	Korbowód trapezowy	MTU MDE

ZAKRES DOSTAWY

Tłoki są dostarczane wraz z dołączonym zestawem pierścieni tłokowych, sworzniem tłokowym i pierścieniami zabezpieczającymi.



TŁOKI GAZOWE BEZ WGŁĘBIENIA — WSKAZÓWKI DOTYCZĄCE OBRÓBK

Przed obróbką tłoka

Należy zapisać wszystkie funkcjonalnie istotne wymiary jako rozmiar referencyjny do porównania przed obróbką i po niej. W tym celu należy zmierzyć tłok w określonych punktach pomiarowych D1 i D2 (patrz rysunek). Zmierzyć tłok przed obróbką i po niej w tych samych warunkach otoczenia, np. w tej samej temperaturze.

Po obróbce i przed montażem tłoka

Oczyszczyć obrobione tłoki, w tym wszystkie kanały olejowe.

- Zmierzyć tłok w określonych punktach pomiarowych D1 i D2 (patrz rysunek) w takich samych warunkach otoczenia jak przed obróbką. Porównać pomiary z wartościami zmierzonymi przed obróbką.
- Po zamontowaniu tłoka należy sprawdzić jego występ. Należy przestrzegać wartości zadanych producenta dotyczących maksymalnego występu tłoka (zastosowanie standardowe).
- Należy przestrzegać ogólnych instrukcji dotyczących profesjonalnego montażu tłoków. Można je znaleźć w katalogu Motorservice „Tłoki i komponenty” nr art. 50 003 945.
- Należy postępować zgodnie z instrukcjami producenta silnika.

Obróbka tłoka gazowego bez wgłębienia

- W przypadku stopów o zawartości krzemu > 10% należy użyć odpowiedniego środka tnącego.
- Należy używać odpowiedniego sprzętu mocującego, który nie wpływa na kontur tłoka i powłokę powierzchni bieżnej.
- Podczas obróbki element musi być odpowiednio chłodzony i smarowany.



PIERŚCIENIE GNIAZD ZAWORÓW — ZALECENIA DOTYCZĄCE STOSOWANIA

Material	Właściwość	Rodzaj paliwa / spalanie	Materiały głowicy cylindra	Silniki
HT*	bardzo wysoka odporność na temperaturę i zużycie	CNG, LPG, flex-fuel, propan	Aluminium, żeliwo szare	Zastosowania gazowe, takie jak LPG, CNG, propan, flex-fuel
HCR	bardzo wysoka odporność na temperaturę i zużycie, wysoka odporność na korozję	CNG, LPG, flex-fuel, propan	Aluminium, żeliwo szare	Zastosowania gazowe, takie jak LPG, CNG, propan, flex-fuel
G7	Wysoka odporność na zużycie i korozję	Otto (benzyna bezołowiowa), Diesel, CNG, LPG, flex-fuel	Aluminium, żeliwo szare	silniki mocno obciążone, silniki o podwyższonej wydajności, zastosowania gazowe, takie jak LPG, CNG, flex-fuel
HWR	zwiększona odporność na temperaturę i zużycie, zmniejszone tarcie	CNG, LPG, flex-fuel, propan	Aluminium, żeliwo szare	Zastosowania gazowe, takie jak LPG, CNG, propan, flex-fuel
G4	bardzo wysoka odporność na temperaturę i zużycie, wysoka odporność na utlenianie	Otto (benzyna bezołowiowa), Diesel, CNG, LPG, flex-fuel	Aluminium, żeliwo szare	silniki mocno obciążone, silniki o podwyższonej wydajności, zastosowania gazowe, takie jak LPG, CNG, flex-fuel
G5, G6	bardzo wysoka odporność na temperaturę i zużycie, wysoka odporność na deformację	Otto (benzyna bezołowiowa), Diesel, CNG, LPG, flex-fuel	Aluminium, żeliwo szare	silniki mocno obciążone, silniki o podwyższonej wydajności, zastosowania gazowe, takie jak LPG, CNG, flex-fuel

PIERŚCIEŃ GNIAZD ZAWORÓW — INSTRUKCJA MONTAŻU

UWAGA

Ekstremalne warunki pracy, jak również wysokie obciążenia danego silnika muszą być brane pod uwagę i leżą w zakresie odpowiedzialności serwisanta silników.

Wybór specyfikacji części silnika musi być starannie przemyślany przez serwisanta silników.

UWAGA

Przy przebudowie należy przestrzegać specyfikacji zaworu.

WSKAZÓWKA

Wymiana pierścieni gniazd zaworów i zaworów w ramach konwersji gazowej zawsze stanowi ingerencję w oryginalne specyfikacje silnika. To, czy nowe pary materiałów będą harmonizować i przynosić pożądane rezultaty w zmienionych warunkach, można tylko oszacować. Należy wziąć pod uwagę ekstremalne warunki pracy i specyficzne obciążenia silnika. Odpowiedzialność za nie spoczywa wyłącznie na osobie doposażającej silnik.

INSTRUKCJA MONTAŻU

Pierścienie gniazd zaworów Kolbenschmidt i TRW Engine Components są zeszlifowane na średnicy zewnętrznej. Wymiar otworu ustalającego w głowicy cylindra można ustalić na podstawie poniższej tabeli nakładek. W przypadku pierścieni gniazd zaworów ze spiekanego metalu kąt gniazda musi być obrobiony po włożeniu. Odlewane pierścienie gniazda są wykończone.

Montaż pierścieni gniazd zaworów z metalu spiekanego

Należy zwrócić uwagę, aby wkładany pierścień gniazda był zawsze montowany stroną z promieniem w dół. Ze względu na promień i „efekt sprężynujący” materiału spiekanego pierścień gniazda zaworu firmy Kolbenschmidt nie wymaga chłodzenia ciekłym azotem ani podgrzewania głowicy cylindra w celu wciśnięcia pierścieni gniazda zaworu do głowicy cylindra. Pierścienie gniazd są wciskane za pomocą odpowiedniego narzędzia w temperaturze pokojowej.

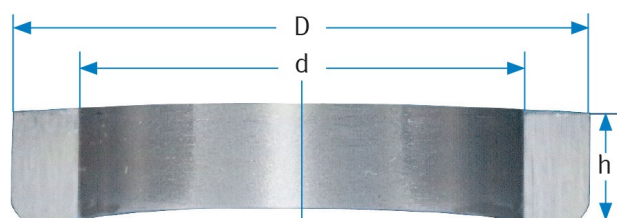

Główne wymiary pierścienia gniazda zaworu

D = średnica zewnętrzna, d = średnica wewnętrzna, h = wysokość

Firmy Kolbenschmidt i TRW Engine Components zalecają następujące nakładki / pasowania wtłaczane

Średnica zewnętrzna pierścienia gniazda zaworu		Głowica cylindra z żeliwa		Głowica cylindra z aluminium	
[mm]	[cal]	[mm]	[cal]	[mm]	[cal]
20–30	0.7874–1.1811	0,06	0,0024	0,08	0,0031
30–40	1.1811–1.5748	0,08	0,0031	0,10	0,0040
40–50	1.5748–1.9685	0,10	0,0040	0,12	0,0047
50–60	1.9685–2.3622	0,12	0,0047	0,14	0,0055
60–70	2.3622–2.7559	0,14	0,0055	0,16	0,0063

PIERŚCIENIE GNIAZD ZAWORÓW – ARTYKUŁY I WYMIARY

Nr art.	Średnica zewnętrzna Ø D (mm)	Średnica wewnętrzna Ø d (mm)	Wysokość h (mm)	Materiał
50 009 500	35,500	28,000	10,000	HT*
50 009 501	37,500	30,000	10,000	HT*
50 009 503	38,230	31,000	8,000	HT*
50 009 504	38,500	31,000	10,000	HT*
50 009 506	40,000	32,000	10,000	HT*
50 009 507	40,500	32,000	10,000	HT*
50 009 508	41,000	30,000	10,000	HT*
50 009 510	42,000	31,000	10,000	HT*
50 009 511	42,000	34,000	10,000	HT*
50 009 512	43,000	32,000	10,000	HT*
50 009 513	43,000	35,000	10,000	HT*
50 009 514	44,130	36,000	9,000	HT*
50 009 515	44,500	30,000	10,000	HT*
50 009 516	44,500	36,000	10,000	HT*
50 009 517	44,500	36,000	11,000	HT*
50 009 518	46,000	34,000	12,000	HT*
50 009 519	48,000	37,000	12,000	HT*
50 009 520	54,200	43,000	10,000	HT*
50 009 522	55,100	43,000	10,000	HT*
50 009 623	31,000	18,000	7,500	HT*
50 009 650	24,000	18,000	8,000	HT*
50 009 651	25,000	19,000	8,000	HT*
50 009 652	28,000	22,000	10,000	HT*
50 009 653	28,500	22,000	10,000	HT*
50 009 654	29,000	23,000	10,000	HT*
50 009 655	29,500	23,000	10,000	HT*
50 009 656	30,000	23,000	10,000	HT*
50 009 657	30,000	20,000	10,000	HT*
50 009 658	30,190	24,100	8,100	HT*
50 009 659	30,500	23,000	10,000	HT*
50 009 660	31,000	24,000	10,000	HT*
50 009 661	31,000	21,000	10,000	HT*
50 009 662	31,500	24,000	10,000	HT*
50 009 663	32,000	24,000	9,000	HT*
50 009 664	32,000	25,000	10,000	HT*
50 009 665	32,000	22,000	10,000	HT*
50 009 666	32,500	25,000	10,000	HT*
50 009 667	33,000	26,000	10,000	HT*
50 009 668	33,000	23,000	10,000	HT*
50 009 669	33,500	26,000	10,000	HT*
50 009 670	34,000	27,000	10,000	HT*
50 009 671	34,000	24,000	10,000	HT*
50 009 672	34,500	27,000	10,000	HT*
50 009 673	35,000	28,000	10,000	HT*

Nr art.	Średnica zewnętrzna Ø D (mm)	Średnica wewnętrzna Ø d (mm)	Wysokość h (mm)	Materiał
50 009 674	35,000	25,000	10,000	HT*
50 009 675	36,000	29,000	10,000	HT*
50 009 676	36,000	26,000	10,000	HT*
50 009 677	36,500	29,000	10,000	HT*
50 009 678	37,000	30,000	10,000	HT*
50 009 679	38,000	31,000	10,000	HT*
50 009 680	38,000	28,000	10,000	HT*
50 009 681	39,000	32,000	10,000	HT*
50 009 682	40,000	29,000	10,000	HT*
50 009 683	41,000	33,000	10,000	HT*
50 009 684	41,500	33,000	10,000	HT*
50 009 685	44,000	33,000	10,000	HT*
50 009 686	45,000	37,000	12,000	HT*
50 009 687	45,000	34,000	12,000	HT*
50 009 688	47,000	36,000	12,000	HT*
50 009 689	54,200	43,000	8,600	HT*
50 009 690	53,200	43,000	7,000	HT*
50 009 691	53,700	43,000	10,000	HT*
50 009 692	54,650	43,690	10,000	HT*
50 009 693	27,000	20,000	8,000	HT*
50 009 694	40,140	33,000	8,000	HT*
50 009 695	42,140	33,000	8,000	HT*
50 009 696	26,700	20,000	5,700	HT*
50 009 697	29,000	18,000	10,000	HT*
50 009 698	31,830	27,400	8,500	HT*
50 009 699	33,700	27,000	8,000	HT*

GŁOWICE CYLINDRÓW DO SILNIKÓW GAZOWYCH — ODPOWIEDNIE DLA MAN, MTU, MDE

Firma Motorservice zoptymalizowała geometrie wszystkich wariantów głowic cylindrów i w ten sposób wspiera użytkowników silników gazowych w osiągnięciu ustawowych wymagań dotyczących emisji. Optymalizacje wpływają pozytywnie na temperaturę spalin. Ponadto poprawia się chłodzenie wszystkich elementów układu rozrządu i otoczenia świecy zapłonowej.

Firma Motorservice oferuje głowicę cylindra w różnych wariantach w zależności od wymagań i zastosowania.

Przegląd wariantów

Wersja	Układ smarowania	Zastosowanie
kompletny, M18	Prowadnica zaworu wydechowego smarowana olejem	Silniki na biogaz
kompletny, M14	Prowadnica zaworu wydechowego smarowana olejem	Silniki na biogaz
kompletny, M14	Prowadnica zaworu wydechowego niesmarowana	Silniki na gaz ziemny
kompletny, M18	Prowadnica zaworu wydechowego chłodzony olejem	Silniki elastyczne



KORZYŚCI

- zoptymalizowane zużycie i dynamika spalin
- zastosowanie do silników wielu producentów i różnych wersji
- możliwość zamontowania czujników spalania stukowego
- poszczególne części, takie jak pierścienie gniazd zaworów, prowadnice zaworów dostępne w Motorservice
- możliwość indywidualnego monitorowania temperatury
- inne warianty według wymagań na zapytanie

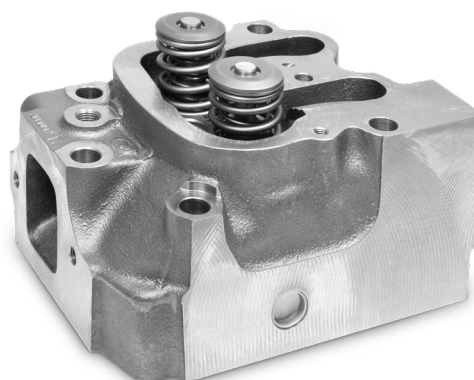

TULEJE WAŁÓW — INSTRUKCJA MONTAŻU

Szybka i łatwa naprawa powierzchni bieżnych wałów

Tuleje wałów są opłacalną alternatywą dla wymiany lub kosztownej przeróbki zużytego lub uszkodzonego wału. Tuleja wału jest po prostu nasuwana na zużytą powierzchnię bieżną wału. Często jest to możliwe po zamontowaniu wału. Po naprawie można zastosować promieniowe uszczelnienia wału o oryginalnych wymiarach.

Dzięki dostarczonej tulei montażowej i odłączanemu kołnierzowi montażowemu montaż tulei wału jest szybki i łatwy.

Przed montażem

- Na wale oczyścić i sprawdzić powierzchnię bieżną uszczelnienia promieniowego wału.
- Ślady zużycia, nacięcia, rowki lub duże chropowatości wypełnić odpowiednią masą wypełniającą. Nierówności wału są wciskane przez ciekłą grubość ścianki tulei wału i negatywnie wpływają na efekt uszczelnienia.
- Określić rozmiar tulei.
- Aby dobrać tuleję wału, należy zmierzyć średnicę wału w trzech różnych punktach w pobliżu zużytego miejsca.

Tuleje wałów dostępne są w zakresie średnic od 12 mm do 200 mm.

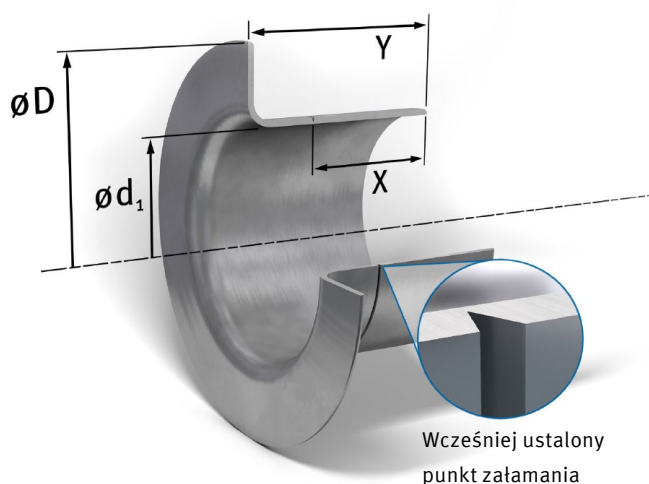

Montaż tulei wału

UWAGA

Tuleje wałów nie mogą być nakładane na rowki, wgłębienia lub wyloty gwintowane w wałach.

UWAGA

Zamontować tuleję wału ostrożnie i bez przechylania na wale. Uszkodzenia powstałe podczas montażu zmniejszają właściwości jezdne i uszczelniające uszczelnienia promieniowego wału.

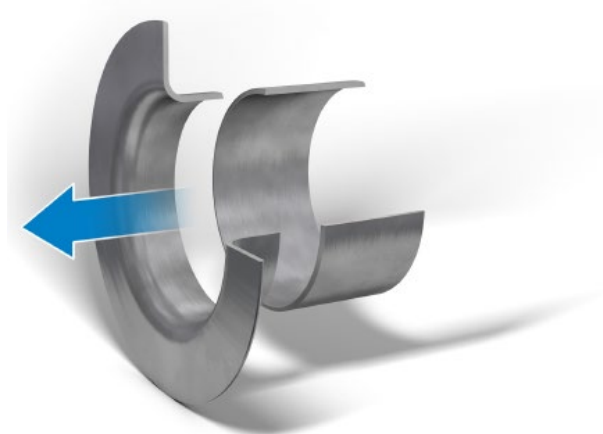

Zdejmowany kołnierz montażowy



- Przed montażem lekko nasmarować powierzchnię wału.
- Umieścić tuleję wału stroną z kołnierzem na wale.



- Nasunąć tuleję montażową na tuleję wału.
- Jeśli tuleja montażowa jest zbyt krótka, jako tuleję montażową można zastosować rurkę.
- Nasunąć tuleję wału z tuleją montażową na zużyte miejsce.



- Przeciąć kołnierz mocujący na tulei wału za pomocą obcinaczek bocznych do ustalonego wcześniej punktu załamania i oddzielić kołnierz na wstępnie wytoczonym rowku.
- Po montażu ponownie sprawdzić powierzchnię wału pod kątem występowania zadziorów.

Demontaż tulei wału

Tuleje wału można zdjąć z wału na różne sposoby:

- poprzez ogrzanie można łatwo ściągnąć termicznie rozszerzoną tuleję wału z wału bez jego uszkodzenia.
- Poprzez kontrolowane uderzenia młotkiem z rębem na szerokości tulei tuleja wału rozszerza się i może być łatwo usunięta.
- Oderwać tuleję wału za pomocą obcinaczek bocznych.
- Rozciąć tuleję wału za pomocą dłuta.

UWAGA

Tuleje wałów nie mogą być ponownie użyte.

TULEJE WAŁÓW — ARTYKUŁY I WYMIARY

Nr art.:	Średnica wału Ø d1 (mm)	Średnica wału min. Ø (mm)	Średnica wału maks. Ø (mm)	Szerokość X (mm)	Szerokość całkowita Y (mm)	Średnica kolnierza Ø D (mm)
50 008 394	76,020	75,950	76,100	14,300	17,500	85,300
50 008 395	117,500	117,380	117,580	25,400	31,800	128,600
50 008 396	120,650	120,550	120,750	12,700	19,100	127,000
50 008 397	145,000	144,750	145,000	19,100	22,200	154,900
50 008 398	171,450	171,320	171,580	20,600	27,000	181,000
50 008 393	71,450	71,350	71,500	15,100	17,500	81,000
50 008 392	65,100	65,020	65,180	19,800	23,800	73,400
50 008 391	59,130	59,100	59,260	19,100	22,200	69,800
50 008 390	50,300	50,220	50,370	14,300	17,900	58,800
50 008 389	41,000	40,840	41,000	12,700	15,900	49,200
50 008 399	184,860	184,740	185,000	32,000	38,000	197,100
50 008 400	200,030	199,870	200,130	34,500	38,100	212,700
50 008 388	38,100	38,020	38,180	9,500	12,700	45,200
50 008 350	129,900	129,790	130,000	19,100	23,800	139,500
50 008 351	29,850	29,800	29,920	8,000	11,100	35,600
50 008 352	43,660	43,560	43,710	14,300	17,500	51,600
50 008 353	95,000	95,000	95,150	11,900	15,100	102,500
50 008 354	95,000	95,000	95,150	8,700	12,700	102,400
50 008 355	160,000	159,740	160,000	25,400	31,800	171,400
50 008 361	17,930	17,880	18,010	8,000	11,000	24,400
50 008 362	24,000	23,880	24,000	8,000	11,100	28,700
50 008 364	44,170	44,090	44,250	9,500	12,700	52,400
50 008 365	53,980	53,920	54,050	12,700	19,100	61,500
50 008 367	69,850	69,850	70,000	28,600	31,800	79,400
50 008 368	125,000	124,890	125,100	10,000	14,000	137,200
50 008 369	150,000	149,750	150,010	26,000	30,000	159,000
50 008 370	180,010	179,750	180,010	33,000	38,000	190,500
50 008 372	22,000	21,870	22,000	6,600	9,100	30,200
50 008 373	22,000	21,870	22,000	8,000	12,000	30,200
50 008 374	33,350	33,270	33,430	12,700	15,900	40,500
50 008 375	36,000	35,840	36,000	13,000	17,000	45,200
50 008 376	42,880	42,770	42,930	14,300	17,500	48,400
50 008 377	69,850	69,720	69,880	19,800	23,790	79,400
50 008 378	79,380	79,250	79,400	17,500	20,600	89,700
50 008 380	125,000	124,890	125,100	26,000	32,000	137,200
50 008 381	177,800	177,670	177,930	25,400	31,800	189,900
50 008 382	190,500	190,370	190,630	20,600	25,400	200,000
50 008 383	15,000	14,960	15,060	5,000	9,000	19,100
50 008 384	19,050	19,000	19,100	8,000	11,100	24,000
50 008 385	25,400	25,350	25,450	8,000	11,100	31,000
50 008 386	30,180	30,100	30,230	8,000	11,100	35,600
50 008 387	29,360	29,310	29,410	9,500	12,700	34,300
50 008 449	104,780			20,600	25,400	113,500
50 008 445	53,980			19,800	23,800	61,500

TULEJE WAŁÓW — ARTYKUŁY I WYMIARY



Nr art.:	Średnica wału Ø d1 (mm)	Średnica wału min. Ø (mm)	Średnica wału maks. Ø (mm)	Szerokość X (mm)	Szerokość całkowita Y (mm)	Średnica kołnierza Ø D (mm)
50 008 441	38,680			11,100	14,300	47,200
50 008 440	38,100			14,300	17,500	45,200
50 008 437	55,580			19,800	23,800	63,500
50 008 428	44,450			13,500	15,900	52,400
50 008 427	44,450			9,500	12,700	52,200
50 008 425	43,000			12,700	15,900	48,400
50 008 424	41,280			14,300	17,500	47,600
50 008 422	36,530			9,500	12,700	45,200
50 008 421	15,880			8,000	10,300	19,100
50 008 458	152,400			25,400	31,800	161,900
50 008 453	95,250			17,500	22,200	102,100
50 008 434	61,920			19,800	23,800	71,800
50 008 432	47,630			14,300	17,500	56,000
50 008 419	34,930			8,000	11,100	41,600
50 008 417	33,350			6,300	9,500	40,600
50 008 416	27,000			8,000	11,100	33,500
50 008 415	31,500			8,000	11,100	39,100
50 008 413	27,660			8,000	11,100	35,700
50 008 412	21,820			6,300	9,500	29,300
50 008 408	19,840			8,700	11,100	23,800
50 008 459	154,860			26,000	30,000	167,000
50 008 452	94,740			19,800	23,000	102,200
50 008 451	88,900			20,600	25,400	97,600
50 008 450	120,000			8,000	11,000	129,800
50 008 431	47,450			22,600	26,000	55,600
50 008 454	95,250			14,300	17,500	102,200
50 008 435	63,500			19,800	23,800	71,600
50 008 433	49,230			14,300	17,500	56,400
50 008 426	44,450			19,100	22,200	52,400
50 008 423	28,580			9,500	12,700	38,100
50 008 414	28,580			8,000	11,100	38,100
50 008 411	24,600			15,900	18,300	28,700
50 008 410	24,600			8,000	11,100	28,700
50 008 409	22,230			8,000	11,100	27,800
50 008 407	17,370			8,000	11,100	22,700
50 008 406	14,300			6,300	9,900	19,100
50 008 420	14,000			6,300	9,900	19,100
50 008 418	34,010			12,700	15,900	41,300
50 008 448	61,930			12,700	15,900	71,800
50 008 447	57,150			19,800	23,800	64,300
50 008 446	56,000			12,700	15,900	64,300
50 008 444	92,080			20,600	25,400	102,400

TULEJE WAŁÓW — ARTYKUŁY I WYMIARY

Nr art.:	Średnica wału Ø d1 (mm)	Średnica wału min. Ø (mm)	Średnica wału maks. Ø (mm)	Szerokość X (mm)	Szerokość całkowita Y (mm)	Średnica kolnierza Ø D (mm)
50 008 443	44,450			14,300	17,500	52,400
50 008 442	39,700			14,300	17,500	47,200
50 008 439	82,550			20,600	25,400	91,300
50 008 438	74,630			19,800	23,800	84,900
50 008 436	63,910			19,800	23,000	71,800
50 008 462	189,310			20,600	25,400	199,600
50 008 461	169,880			31,800	38,000	182,600
50 008 460	175,010			28,000	32,000	187,000
50 008 457	127,000			17,500	22,200	137,200
50 008 456	165,100			25,400	31,800	177,800
50 008 455	134,950			20,500	25,400	145,700
50 008 430	47,220			14,300	17,500	54,800
50 008 323	100,000	99,950	100,110	20,600	25,400	109,500
50 008 324	75,000	74,930	75,080	15,100	17,500	83,100
50 008 325	120,000	119,890	120,090	20,000	25,000	129,800
50 008 326	105,000	104,900	105,100	20,000	23,200	113,500
50 008 327	25,000	24,940	25,040	8,000	11,000	33,000
50 008 328	31,800	31,670	31,830	8,000	11,100	38,100
50 008 329	41,900	41,830	42,000	11,300	14,500	53,000
50 008 330	70,000	69,930	70,080	20,000	24,000	79,400
50 008 331	80,000	79,910	80,090	21,000	24,000	90,000
50 008 332	130,180	129,970	130,180	22,000	25,300	139,500
50 008 333	84,070	84,000	84,150	20,600	25,400	93,700
50 008 334	28,000	27,940	28,040	9,500	12,700	34,900
50 008 335	48,030	47,930	48,090	14,000	17,000	56,000
50 008 336	62,000	61,820	62,000	12,700	15,900	71,800
50 008 337	72,000	71,830	72,000	19,100	22,200	81,900
50 008 338	75,000	74,930	75,080	22,000	26,000	84,000
50 008 339	90,000	89,910	90,070	18,000	23,000	101,600
50 008 340	90,000	89,910	90,070	23,000	28,000	101,600
50 008 341	17,000	16,940	17,040	8,000	11,000	22,200
50 008 342	38,000	37,850	38,000	13,000	17,000	45,200
50 008 343	140,000	139,900	140,110	20,500	25,400	151,000
50 008 344	34,930	34,820	34,980	12,700	15,900	41,600
50 008 345	41,900	41,830	42,000	14,300	17,500	53,000
50 008 346	68,000	67,820	68,000	19,100	22,200	79,400
50 008 347	69,850	69,850	70,000	19,800	23,800	79,400
50 008 348	46,050	45,950	46,100	14,300	17,500	53,100
50 008 349	60,330	60,300	60,450	13,400	17,400	69,800
50 008 322	95,000	94,920	95,080	21,000	24,000	102,200
50 008 429	45,240			16,900	20,300	54,000
50 008 405	52,000			12,700	15,900	62,700
50 008 404	66,000			19,800	23,800	76,000
50 008 403	110,000	109,779	109,982	11,400	15,000	125,000

TULEJE WAŁÓW — ARTYKUŁY I WYMIARY

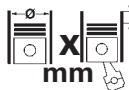
Nr art.:	Średnica wału Ø d1 (mm)	Średnica wału min. Ø (mm)	Średnica wału maks. Ø (mm)	Szerokość X (mm)	Szerokość całkowita Y (mm)	Średnica kołnierza Ø D (mm)
50 008 402	78,000			19,100	22,200	88,000
50 008 401	133,350			20,600	25,400	141,200
50 008 300	32,000	31,920	32,080	8,000	11,100	38,100
50 008 301	80,000	79,910	80,090	11,000	15,000	90,000
50 008 302	109,930	109,910	110,110	12,900	16,500	125,000
50 008 303	34,930	34,930	35,080	13,000	16,000	41,600
50 008 304	65,000	64,920	65,080	20,000	23,000	72,400
50 008 306	115,000	114,890	115,090	20,600	23,800	127,000
50 008 307	45,000	44,930	45,090	14,000	17,000	53,000
50 008 308	85,000	84,790	85,000	10,100	12,700	90,900
50 008 309	40,080	39,930	40,080	13,000	16,000	47,000
50 008 310	50,000	49,910	50,060	14,000	17,000	57,000
50 008 311	30,000	29,950	30,070	8,000	11,000	35,600
50 008 312	26,010	25,880	26,010	8,000	12,000	33,400
50 008 313	84,890	84,760	85,010	17,000	21,000	94,000
50 008 314	20,000	19,940	20,040	8,000	11,000	23,600
50 008 315	55,000	54,910	55,070	20,000	23,000	62,000
50 008 316	90,000	89,910	90,070	13,400	16,900	101,600
50 008 317	60,000	59,920	60,070	9,400	11,400	70,700
50 008 318	69,850	69,850	70,000	10,300	14,300	79,400
50 008 319	60,000	59,920	60,070	20,000	23,000	70,700
50 008 320	79,910	79,810	80,010	19,100	22,500	89,900
50 008 379	101,600	101,550	101,750	20,600	25,400	111,100
50 008 371	12,000	11,910	12,070	6,000	8,400	15,500
50 008 366	57,150	57,120	57,280	8,000	11,100	64,300
50 008 363	40,000	39,850	40,000	9,900	12,900	46,900
50 008 360	50,800	50,720	50,880	14,300	17,500	61,100
50 008 359	44,860	44,730	44,880	14,300	17,500	52,400
50 008 358	42,060	41,990	42,140	14,000	17,500	53,000
50 008 357	39,420	39,340	39,500	11,100	14,300	47,200
50 008 356	16,000	15,900	16,000	8,000	11,100	18,200
50 008 321	84,890	84,760	85,010	21,000	25,000	94,000
50 008 305	90,000	89,910	90,070	11,100	13,700	101,600

	Cyl.		 mm	cm ³		Comp. Ratio ε	kW	PS	Pos
	BFG 6 M 1015 C	G (A)	6	132 x 145	11910	2	10:1	142	193
BFG 8 M 1015 C	G (A)	8	132 x 145	15870	2	10:1	190	258	2

D

1

132

BFG 6 M 1015 C

 G A 6 11910 cm³ 2V 142 kW 193 PS ξ 10:1 \bar{h} 145

94 728 600

\varnothing cylindra: 132; KH: 86.8; MT: -26.6; M \varnothing : 92.9; GL: 133.8; sworze tłokowy: 52x110; Liczba pierieni: 3
 RTK
 T15 3.5 CR G6
 M 2.45 CR G6
 DSF 4 CR

D

89 443 110

N - Mokra tuleja cylindra; skoczony; A=147 C=158 L=268.5 H+F=9+1.2

20 0505 10156

rednica kołnierza koła zamachowego: 115

22210

EX; 42 x 8 x 133 x RA/S - Cr - 45° - 22 - III

81-22111

IN/EX; 15.03/ x 8.03 x 66 G2

22321

IN; 46 x 8 x 133 x A/S - Cr - 30° - VS - 22 - III

20 0105 10150

 mech.; \varnothing zewnętrzna: 35; \varnothing wewnętrzna: 25; Długo: 77

2

132

BFG 8 M 1015 C

 G A 8 15870 cm³ 2V 190 kW 258 PS ξ 10:1 \bar{h} 145

94 728 600

\varnothing cylindra: 132; KH: 86.8; MT: -26.6; M \varnothing : 92.9; GL: 133.8; sworze tłokowy: 52x110; Liczba pierieni: 3
 RTK
 T15 3.5 CR G6
 M 2.45 CR G6
 DSF 4 CR

89 443 110

N - Mokra tuleja cylindra; skoczony; A=147 C=158 L=268.5 H+F=9+1.2

22210

EX; 42 x 8 x 133 x RA/S - Cr - 45° - 22 - III

81-22111



IN/EX; 15.03/ x 8.03 x 66 G2

22321





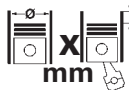

IN; 46 x 8 x 133 x A/S - Cr - 30° - VS - 22 - III







20 0105 10150



 mech.; \varnothing zewnętrzna: 35; \varnothing wewnętrzna: 25; Długo: 77

	Cyl.			cm ³		Comp. Ratio ε	kW	PS	Pos
			mm						
GV158TI	G	8	128 x 142	14618	2	10,5:1	313	426	1
GV180TI	G	10	128 x 142	18273	2	10,5:1	340	462	2
GV222TI	G	12	128 x 142	21915	2	10,5:1	358	486	3
P222LE-II	G	12	128 x 142	21915	2	14,9:1	652	886	4









D

1		128								
GV158TI		G	8	14618 cm ³	2V	313 kW	426 PS	ε 10,5:1	H 142	
	89 092 120	N - Mokra tuleja cylindra; skoczony; A=144.5 C=153.8 L=253 H+F=10.05+1								
	78 693 600	[para] HL STD Ø 104.000 / 111.000 / 30.500 / 3.472 St/B/G1 78 693 610 0,25 / 78 693 620 0,50 / 78 693 630 0,75 / 78 693 640 1,00								
	78 694 604	[para] PASS-L STD Ø 104.000 / 111.000 / 37.810 / 3.474 St/B/G 78 694 614 0,25 / 78 694 624 0,50 / 78 694 634 0,75 / 78 694 644 1,00								
	78 897 600	[para] PL STD Ø 90.000 / 95.000 / 31.000 / 2.473 St/B/S; PL STD Ø 90.000 / 95.000 / 31.000 / 2.473 St/B/G1 78 897 610 0,25 / 78 897 620 0,50 / 78 897 630 0,75 / 78 897 640 1,00, Górna panewka jest oznakowana 'SPUTTER'.								
	79 443 600	[para] PL STD Ø 90.000 / 95.000 / 31.000 / 2.473 St/B/S, SPUTTER: u góry i u dołu, zastosowanie GAS								
	87 348 690	[komplet] PL-B SEMI Ø 46.000 / 50.600 / 38.700 / St/B								
	87 385 694	[komplet] NW-L SEMI Ø 69.940 / 76.000 / 35.000 / St/B; NW-L SEMI Ø 69.940 / 75.000 / 28.000 / St/W								
	87 401 604	[komplet] HL STD Ø 104.000 / 111.000 / 30.500 / 3.472 St/B/G1; PASS-L STD Ø 104.000 / 111.000 / 37.810 / 3.474 St/B/G 87 401 614 0,25 / 87 401 624 0,50 / 87 401 634 0,75 / 87 401 644 1,00								
	25311	EX; 51 x 12 x 142.5 x I/S - Cr - 30° - VS - 1 - III		81-25102	EX; 18/ x 12.02 x 56 G2					
	25310	IN; 58 x 12 x 142.5 x I/S - Cr - 30° - VS - 1 - III		81-25101	IN; 18/ x 12.02 x 59.5 G2					
	92-25004	EX; 53.1 x 43 x 7.45; G2; 30°		81-2536	IN/EX; 18/ x 12 x 64 G2, W przypadku stosowania gazu uywa tylko w obszarze dolotu.					
	92-25018	EX; 53.11 x 43 x 9.5; HWR								
	92-25005	IN; 61.11 x 49 x 6.8; G2; 30°								
	92-25019	IN; 61.11 x 49 x 8.8; HWR								
	20 1402 28000									



2		128								
GV180TI		G	10	18273 cm ³	2V	340 kW	462 PS	ε 10,5:1	H 142	
	89 092 120	N - Mokra tuleja cylindra; skoczony; A=144.5 C=153.8 L=253 H+F=10.05+1								
	78 693 600	[para] HL STD Ø 104.000 / 111.000 / 30.500 / 3.472 St/B/G1 78 693 610 0,25 / 78 693 620 0,50 / 78 693 630 0,75 / 78 693 640 1,00								
	78 694 604	[para] PASS-L STD Ø 104.000 / 111.000 / 37.810 / 3.474 St/B/G 78 694 614 0,25 / 78 694 624 0,50 / 78 694 634 0,75 / 78 694 644 1,00								
	78 897 600	[para] PL STD Ø 90.000 / 95.000 / 31.000 / 2.473 St/B/S; PL STD Ø 90.000 / 95.000 / 31.000 / 2.473 St/B/G1 78 897 610 0,25 / 78 897 620 0,50 / 78 897 630 0,75 / 78 897 640 1,00, Górna panewka jest oznakowana 'SPUTTER'.								
	79 443 600	[para] PL STD Ø 90.000 / 95.000 / 31.000 / 2.473 St/B/S, SPUTTER: u góry i u dołu, zastosowanie GAS								
	87 347 690	[komplet] PL-B SEMI Ø 46.000 / 50.600 / 38.700 / St/B								
	87 399 604	[komplet] HL STD Ø 104.000 / 111.000 / 30.500 / 3.472 St/B/G1; PASS-L STD Ø 104.000 / 111.000 / 37.810 / 3.474 St/B/G 87 399 614 0,25 / 87 399 624 0,50 / 87 399 634 0,75								
	25311	EX; 51 x 12 x 142.5 x I/S - Cr - 30° - VS - 1 - III		81-25102	EX; 18/ x 12.02 x 56 G2					
	25310	IN; 58 x 12 x 142.5 x I/S - Cr - 30° - VS - 1 - III		81-25101	IN; 18/ x 12.02 x 59.5 G2					
	92-25004	EX; 53.1 x 43 x 7.45; G2; 30°		81-2536	IN/EX; 18/ x 12 x 64 G2, W przypadku stosowania gazu uywa tylko w obszarze dolotu.					
	92-25018	EX; 53.11 x 43 x 9.5; HWR								
	92-25005	IN; 61.11 x 49 x 6.8; G2; 30°								
	92-25019	IN; 61.11 x 49 x 8.8; HWR								

3		128								
GV222TI		G	12	21915 cm ³	2V	358 kW	486 PS	ε 10,5:1	H 142	
	89 092 120	N - Mokra tuleja cylindra; skoczony; A=144.5 C=153.8 L=253 H+F=10.05+1								
	78 693 600	[para] HL STD Ø 104.000 / 111.000 / 30.500 / 3.472 St/B/G1 78 693 610 0,25 / 78 693 620 0,50 / 78 693 630 0,75 / 78 693 640 1,00								
	78 694 604	[para] PASS-L STD Ø 104.000 / 111.000 / 37.810 / 3.474 St/B/G 78 694 614 0,25 / 78 694 624 0,50 / 78 694 634 0,75 / 78 694 644 1,00								
	78 897 600	[para] PL STD Ø 90.000 / 95.000 / 31.000 / 2.473 St/B/S; PL STD Ø 90.000 / 95.000 / 31.000 / 2.473 St/B/G1 78 897 610 0,25 / 78 897 620 0,50 / 78 897 630 0,75 / 78 897 640 1,00, Górna panewka jest oznakowana 'SPUTTER'.								
	79 443 600	[para] PL STD Ø 90.000 / 95.000 / 31.000 / 2.473 St/B/S, SPUTTER: u góry i u dołu, zastosowanie GAS								
	87 346 690	[komplet] PL-B SEMI Ø 46.000 / 50.600 / 38.700 / St/B								





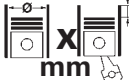



















cont...

87 397 604	[komplet] HL STD \varnothing 104.000 / 111.000 / 30.500 / 3.472 St/B/G1; PASS-L STD \varnothing 104.000 / 111.000 / 37.810 / 3.474 St/B/G 87 397 614 0,25 / 87 397 624 0,50		
 25311 25310	EX; 51 x 12 x 142.5 x I/S - Cr - 30° - VS - 1 - III IN; 58 x 12 x 142.5 x I/S - Cr - 30° - VS - 1 - III	 81-25102 81-25101	EX; 18/ x 12.02 x 56 G2 IN; 18/ x 12.02 x 59.5 G2
 92-25004	EX; 53.1 x 43 x 7.45; G2; 30°	81-2536	IN/EX; 18/ x 12 x 64 G2, W przypadku stosowania gazu uywa tylko w obszarze dolotu.
92-25018 92-25005 92-25019	EX; 53.11 x 43 x 9.5; HWR IN; 61.11 x 49 x 6.8; G2; 30° IN; 61.11 x 49 x 8.8; HWR		
4	 128		
 P222LE-II	G	12	21915 cm ³ 2V 652 kW 886 PS ξ 14,9:1 142
 89 092 110	N - Mokra tuleja cylindra; skoczony; A=144.5 C=153.8 L=253 H+F=10.05+1, W przypadku silników na gaz, do łodzi, kolejowych i stacjonarnych oraz zasilania paliwami alternatywnymi, stosowa tylko ze specjalnym zestawem piercieni uszczelniających 50 007 891.		
 78 693 600	[para] HL STD \varnothing 104.000 / 111.000 / 30.500 / 3.472 St/B/G1 78 693 610 0,25 / 78 693 620 0,50 / 78 693 630 0,75 / 78 693 640 1,00		
78 694 604	[para] PASS-L STD \varnothing 104.000 / 111.000 / 37.810 / 3.474 St/B/G 78 694 614 0,25 / 78 694 624 0,50 / 78 694 634 0,75 / 78 694 644 1,00		
78 897 600	[para] PL STD \varnothing 90.000 / 95.000 / 31.000 / 2.473 St/B/S; PL STD \varnothing 90.000 / 95.000 / 31.000 / 2.473 St/B/G1 78 897 610 0,25 / 78 897 620 0,50 / 78 897 630 0,75 / 78 897 640 1,00, Górna panewka jest oznakowana 'SPUTTER'.		
79 443 600	[para] PL STD \varnothing 90.000 / 95.000 / 31.000 / 2.473 St/B/S, SPUTTER: u góry i u dołu, zastosowanie GAS		
87 346 690	[komplet] PL-B SEMI \varnothing 46.000 / 50.600 / 38.700 / St/B		
87 397 604	[komplet] HL STD \varnothing 104.000 / 111.000 / 30.500 / 3.472 St/B/G1; PASS-L STD \varnothing 104.000 / 111.000 / 37.810 / 3.474 St/B/G 87 397 614 0,25 / 87 397 624 0,50		
 81-2536	IN/EX; 18/ x 12 x 64 G2, W przypadku stosowania gazu uywa tylko w obszarze dolotu.	 92-25003 92-25002	EX; 53.11 x 43 x 9.9; G1; 45° IN; 61.11 x 49 x 8.8; G1; 30°





ENERGIE 2G



		Cyl.	 X mm	cm ³		Comp. Ratio ε	kW	PS	Pos
									Pos
E2842E312		G 12	128 x 142	21915	4		240	326	6
E2842LE322		G (LA) 12	128 x 142	21915	4		370	503	7
E2842LE322		G (LA) 12	128 x 142	21915	4		400	544	8
E2848LE322		G (LA) 8	128 x 142	14618	4		250	340	9
E2876E312		G 6	128 x 166	12816	4	12,0:1	140	190	10
E2876LE302		G (LA) 6	128 x 166	12816	4		190	258	11
E2876LE302		G (LA) 6	128 x 166	12816	4		200	272	12
206 BG		G 1	128 x 166	12816	4	14,8:1	220	299	1
206 EG		G 1	128 x 166	12816	4	13,5:1	231	314	2
208		G 1	128 x 142	14618	4	14,8:1	265	360	3
212		G 1	128 x 142	21915	4	14,8:1	400	544	4
306 BG		G 1	128 x 166	12816	4	14,8:1	250	340	5
312		G 1	128 x 142	21915	4	14,8:1	450	612	4

E

1		128								
	206 BG	G	1	12816 cm ³	4V	220 kW	299 PS	ξ 14,8:1	 166	
	AGENITOR									
	80 00717 1 0 000	Ø128; STD; Zestaw: 1; [T15 G6 CK 4] [M G3 3] [DSF CR 4]								
	80 01100 1 0 000	Ø128; STD; Zestaw: 1; [T15 G6 CK 4] [M G3 CR 3] [DSF CR 4]								
	89 186 120	N - Mokra tuleja cylindra; skoczony; A=144.5 C=153.8 L=270 H+F=10.07+1								
	79 444 600	[para] PL STD Ø 90.000 / 95.000 / 36.200 / 2.479 St/B/S, SPUTTER: u góry i u dołu, zastosowanie GAS								
	20 0602 G2876	Długo: 256; rednica otworu lepego duej głowki korbowodu: 95; rednica małej głowki korbowodu: 50.06; Szeroko stopy korbowodu: 45.85; Szeroko łba korbowodu: 39; korbowód trapezowy; krakowany								
	20 0502 28760	rednica kołnierza koła zamachowego: 113								
	20 0302 28661	bez tulei cylindra								
	20 0802 G2828	- V - G - S - - - - ; element gotowy do montau								
	25311	EX; 51 x 12 x 142.5 x I/S - Cr - 30° - VS - 1 - III		81-25103	EX; 18/ x 12 x 70 G2, Długo rowka olejowego jest różna w zalenoci od głowicy! 81-25103 ma krótki rowek olejowy. Dopiero po wymontowaniu przewodnicy zaworu mona stwierdzi jej wersj. Nie mona odróni wersji po numerach silnika.					
	25310	IN; 58 x 12 x 142.5 x I/S - Cr - 30° - VS - 1 - III		81-25113	EX; 18/ x 12.01 x 70 G2					
	92-25018	EX; 53.11 x 43 x 9.5; HWR		81-25101	IN; 18/ x 12.02 x 59.5 G2					
	92-25019	IN; 61.11 x 49 x 8.8; HWR		81-2536	IN/EX; 18/ x 12 x 64 G2, W przypadku stosowania gazu uywa tylko w obszarze dolotu.					
	20 1002 G2866									
2		128								
	206 EG	G	1	12816 cm ³	4V	231 kW	314 PS	ξ 13,5:1	 166	
	AGENITOR									
	80 00717 1 0 000	Ø128; STD; Zestaw: 1; [T15 G6 CK 4] [M G3 3] [DSF CR 4]								
	80 01100 1 0 000	Ø128; STD; Zestaw: 1; [T15 G6 CK 4] [M G3 CR 3] [DSF CR 4]								
	89 186 120	N - Mokra tuleja cylindra; skoczony; A=144.5 C=153.8 L=270 H+F=10.07+1								
3		128								
	208	G	1	14618 cm ³	4V	265 kW	360 PS	ξ 14,8:1	 142	
	AGENITOR									
	80 00717 1 0 000	Ø128; STD; Zestaw: 1; [T15 G6 CK 4] [M G3 3] [DSF CR 4]								
	89 092 120	N - Mokra tuleja cylindra; skoczony; A=144.5 C=153.8 L=253 H+F=10.05+1								
	89 389 110	N - Mokra tuleja cylindra; skoczony; A=144.5 C=153.8 L=253 H+F=9.92+1, W przypadku silników na gaz, do łodzi, kolejowych i stacjonarnych oraz zasilania paliwami alternatywnymi, stosowa tylko ze specjalnym zestawem piercieni uszczelniających 50 007 890.								
	89 389 810	N - Mokra tuleja cylindra; skoczony; A=144.5 C=153.8 L=253 H+F=9.92+1, W przypadku silników na gaz, do łodzi, kolejowych i stacjonarnych oraz zasilania paliwami alternatywnymi, stosowa tylko ze specjalnym zestawem piercieni uszczelniających 50 007 890.								
	78 693 600	[para] HL STD Ø 104.000 / 111.000 / 30.500 / 3.472 St/B/G1 78 693 610 0,25 / 78 693 620 0,50 / 78 693 630 0,75 / 78 693 640 1,00								
	78 694 604	[para] PASS-L STD Ø 104.000 / 111.000 / 37.810 / 3.474 St/B/G 78 694 614 0,25 / 78 694 624 0,50 / 78 694 634 0,75 / 78 694 644 1,00								
	79 443 600	[para] PL STD Ø 90.000 / 95.000 / 31.000 / 2.473 St/B/S, SPUTTER: u góry i u dołu, zastosowanie GAS								

cont...



87 385 600	[komplet] NW-L STD Ø 69.940 / 76.000 / 35.000 / 3.000 St/B; NW-L STD Ø 69.940 / 75.000 / 28.000 / 2.500 St/A
87 401 604	[komplet] HL STD Ø 104.000 / 111.000 / 30.500 / 3.472 St/B/G1; PASS-L STD Ø 104.000 / 111.000 / 37.810 / 3.474 St/B/G 87 401 614 0,25 / 87 401 624 0,50 / 87 401 634 0,75 / 87 401 644 1,00
 20 0602 G2801	Długo: 256; rednica otworu lepego duej główki korbowodu: 95; rednica małej główki korbowodu: 46; Szeroko stopy korbowodu: 33; Szeroko łba korbowodu: 39; korbowód trapezowy; krakowany
 20 0302 25380	bez tulei cylindra
 20 0802 G2828	- V - G - S - - - -; element gotowy do montau
 81-25103	EX; 18/ x 12 x 70 G2, Długo rowka olejowego jest różna w zalenoci od głowicy! 81-25103 ma krótki rowek olejowy. Dopiero po wymontowaniu przewodnicy zaworu mona stwierdzi jej wersj. Nie mona odróni wersji po numerach silnika.
81-25113	EX; 18/ x 12.01 x 70 G2
81-25101	IN; 18/ x 12.02 x 59.5 G2
81-2536	IN/EX; 18/ x 12 x 64 G2, W przypadku stosowania gazu uywa tylko w obszarze dolotu.
 20 1403 44400	



 92-25018	EX; 53.11 x 43 x 9.5; HWR
 92-25019	IN; 61.11 x 49 x 8.8; HWR

E





4	 128
 212	G 1 21915 cm ³ 4V 400 kW 544 PS € 14,8:1 142
312	G 1 21915 cm ³ 4V 450 kW 612 PS € 14,8:1 142
 AGENITOR	

 78 693 600	[para] HL STD Ø 104.000 / 111.000 / 30.500 / 3.472 St/B/G1 78 693 610 0,25 / 78 693 620 0,50 / 78 693 630 0,75 / 78 693 640 1,00
78 694 604	[para] PASS-L STD Ø 104.000 / 111.000 / 37.810 / 3.474 St/B/G 78 694 614 0,25 / 78 694 624 0,50 / 78 694 634 0,75 / 78 694 644 1,00
79 443 600	[para] PL STD Ø 90.000 / 95.000 / 31.000 / 2.473 St/B/S, SPUTTER: u góry i u dołu, zastosowanie GAS
87 366 600	[komplet] NW-L STD Ø 69.940 / 76.000 / 35.000 / 3.000 St/B; NW-L STD Ø 69.940 / 75.000 / 28.000 / 2.500 St/A
87 397 604	[komplet] HL STD Ø 104.000 / 111.000 / 30.500 / 3.472 St/B/G1; PASS-L STD Ø 104.000 / 111.000 / 37.810 / 3.474 St/B/G 87 397 614 0,25 / 87 397 624 0,50

 20 0602 G2801	Długo: 256; rednica otworu lepego duej główki korbowodu: 95; rednica małej główki korbowodu: 46; Szeroko stopy korbowodu: 33; Szeroko łba korbowodu: 39; korbowód trapezowy; krakowany
 20 0302 28420	bez tulei cylindra
 20 0802 G2828	- V - G - S - - - -; element gotowy do montau

 81-25103	EX; 18/ x 12 x 70 G2, Długo rowka olejowego jest różna w zalenoci od głowicy! 81-25103 ma krótki rowek olejowy. Dopiero po wymontowaniu przewodnicy zaworu mona stwierdzi jej wersj. Nie mona odróni wersji po numerach silnika.
81-25113	EX; 18/ x 12.01 x 70 G2
81-25101	IN; 18/ x 12.02 x 59.5 G2
81-2536	IN/EX; 18/ x 12 x 64 G2, W przypadku stosowania gazu uywa tylko w obszarze dolotu.
 92-25018	EX; 53.11 x 43 x 9.5; HWR
 92-25019	IN; 61.11 x 49 x 8.8; HWR

5	 128
 306 BG	G 1 12816 cm ³ 4V 250 kW 340 PS € 14,8:1 166
 AGENITOR	

 80 00717 1 0 000	Ø128; STD; Zestaw: 1; [T15 G6 CK 4] [M G3 3] [DSF CR 4]
 80 01100 1 0 000	Ø128; STD; Zestaw: 1; [T15 G6 CK 4] [M G3 CR 3] [DSF CR 4]
 89 186 120	N - Mokra tuleja cylindra; skoczony; A=144.5 C=153.8 L=270 H+F=10.07+1
 89 914 110	N - Mokra tuleja cylindra; skoczony; A=144.5 C=153.8 L=270 H+F=10.07+1, W przypadku silników na gaz, do łodzi, kolejowych i stacjonarnych oraz zasilania paliwami alternatywnymi, stosowa tylko ze specjalnym zestawem piercieni uszczelniających 50 007 891., płaszcz wodny powlek. plazmowo

cont..

	89 390 120	N - Mokra tuleja cylindra; skoczony; A=144.5 C=153.8 L=270 H+F=9.92+1
	79 444 600	[para] PL STD Ø 90.000 / 95.000 / 36.200 / 2.479 St/B/S, SPUTTER: u góry i u dołu, zastosowanie GAS
	20 6002 G2876	Długo: 256; rednica otworu lepego duej główki korbowodu: 95; rednica małej główki korbowodu: 50.06; Szeroko stopy korbowodu: 45.85; Szeroko łba korbowodu: 39; korbowód trapezowy; krakowany
	20 0502 28760	rednica kołnierza koła zamachowego: 113
	20 0302 28661	bez tulei cylindra
	20 0802 G2828	- V - G - S - - - -; element gotowy do montau
	25311	EX; 51 x 12 x 142.5 x I/S - Cr - 30° - VS - 1 - III
	25310	IN; 58 x 12 x 142.5 x I/S - Cr - 30° - VS - 1 - III
	92-25018	EX; 53.11 x 43 x 9.5; HWR
	92-25019	IN; 61.11 x 49 x 8.8; HWR
	81-25103	EX; 18/ x 12 x 70 G2, Długo rowka olejowego jest różna w zalenoci od głowicy! 81-25103 ma krótki rowek olejowy. Dopiero po wymontowaniu przewodnicy zaworu mona stwierdzi jej wersj. Nie mona odróni wersji po numerach silnika.
	81-25113	EX; 18/ x 12.01 x 70 G2
	81-25101	IN; 18/ x 12.02 x 59.5 G2
	81-2536	IN/EX; 18/ x 12 x 64 G2, W przypadku stosowania gazu uywa tylko w obszarze dolotu.
	20 1002 G2866	

E

6		128							
	E2842E312		G	12	21915 cm ³	4V	240 kW	326 PS	
	PATRUUS								

	40 208 600	Ø cylindra: 128; KH: 80.7; MT: -28.2; MØ: 94; GL: 129.7; sworze tłokowy: 46x105; Liczba piercieni: 3 RTK T15 3.5 CR G6 M 3 DSF 5 CR → 80 00155 1 0 ...
	42 043 600	Ø cylindra: 128; KH: 80.7; MT: -21.7; MØ: 90; GL: 129.7; sworze tłokowy: 46x105; Liczba piercieni: 3 RTK T15 3.5 CR G6 M 3 DSF 5 CR → 80 00155 1 0 ...
	94 942 600	Ø cylindra: 128; KH: 80.7; MT: -29; MØ: 96; GL: 130; sworze tłokowy: 46x105; Liczba piercieni: 3 FBo, RTK T15 3.5 CR G6 M 3 DSF 5 CR → 80 00155 1 0 ... Stopie sprania 10:1
	94 943 600	Ø cylindra: 128; KH: 80.7; MT: -22; MØ: 96; GL: 130; sworze tłokowy: 46x105; Liczba piercieni: 3 FBo, RTK T15 3.5 CR G6 M 3 DSF 5 CR → 80 00155 1 0 ...
	80 00155 1 0 000	Ø128; STD; Zestaw: 1; [T15 G6 CR 3.5] [M 3] [DSF CR 5]
	42 043 960	tłoki: 42043600; tuleja cylindrowa: 89092120
	94 943 960	tłoki: 94943600; tuleja cylindrowa: 89092120
	89 092 120	N - Mokra tuleja cylindra; skoczony; A=144.5 C=153.8 L=253 H+F=10.05+1

cont...

	78 693 600	[para] HL STD Ø 104.000 / 111.000 / 30.500 / 3.472 St/B/G1 78 693 610 0,25 / 78 693 620 0,50 / 78 693 630 0,75 / 78 693 640 1,00
	78 694 604	[para] PASS-L STD Ø 104.000 / 111.000 / 37.810 / 3.474 St/B/G 78 694 614 0,25 / 78 694 624 0,50 / 78 694 634 0,75 / 78 694 644 1,00
	78 897 600	[para] PL STD Ø 90.000 / 95.000 / 31.000 / 2.473 St/B/S; PL STD Ø 90.000 / 95.000 / 31.000 / 2.473 St/B/G1 78 897 605 0,10 / 78 897 610 0,25 / 78 897 620 0,50 / 78 897 630 0,75 / 78 897 640 1,00, Górna panewka jest oznakowana 'SPUTTER'.
	79 443 600	[para] PL STD Ø 90.000 / 95.000 / 31.000 / 2.473 St/B/S, SPUTTER: u góry i u dołu, zastosowanie GAS
	87 366 600	[komplet] NW-L STD Ø 69.940 / 76.000 / 35.000 / 3.000 St/B; NW-L STD Ø 69.940 / 75.000 / 28.000 / 2.500 St/A
	87 397 604	[komplet] HL STD Ø 104.000 / 111.000 / 30.500 / 3.472 St/B/G1; PASS-L STD Ø 104.000 / 111.000 / 37.810 / 3.474 St/B/G 87 397 614 0,25 / 87 397 624 0,50

E

	20 0602 G2801	Długo: 256; rednica otworu lepego duej główki korbowodu: 95; rednica małej główki korbowodu: 46; Szeroko stopy korbowodu: 33; Szeroko łba korbowodu: 39; korbowód trapezowy; krakowany
---	----------------------	--

	20 0302 28420	bez tulei cylindra
---	----------------------	--------------------

	20 0802 G2840	- V - G - S - - - - ; element gotowy do montau, Uywaj do wiecy zapłonowej M14
---	----------------------	---

	25311	EX; 51 x 12 x 142.5 x l/S - Cr - 30° - VS - 1 - III		81-25102	EX; 18/ x 12.02 x 56 G2
	25310	IN; 58 x 12 x 142.5 x l/S - Cr - 30° - VS - 1 - III		81-25101	IN; 18/ x 12.02 x 59.5 G2
	92-25004	EX; 53.1 x 43 x 7.45; G2; 30°		81-2536	IN/EX; 18/ x 12 x 64 G2, W przypadku stosowania gazu uywa tylko w obszarze dolotu.
	92-25018	EX; 53.11 x 43 x 9.5; HWR			
	92-25005	IN; 61.11 x 49 x 6.8; G2; 30°			
	92-25019	IN; 61.11 x 49 x 8.8; HWR			

	20 1403 44300	
--	----------------------	--

7		128								
	E2842LE322		G	LA	12	21915 cm ³	4V	370 kW	503 PS	 142
	PATRUUS									

	40 208 600	Ø cylindra: 128; KH: 80.7; MT: -28.2; MØ: 94; GL: 129.7; sworze tłokowy: 46x105; Liczba piercieni: 3 RTK T15 3.5 CR G6 M 3 DSF 5 CR → 80 00155 1 0 ...
---	-------------------	--

	41 000 600	Ø cylindra: 128; KH: 80.7; MT: -26; MØ: 91.6; GL: 129.7; sworze tłokowy: 46x105; Liczba piercieni: 3 RTK T15 4 CK G6 M 3 CR G3 DSF 4 CR
---	-------------------	---

	42 043 600	Ø cylindra: 128; KH: 80.7; MT: -21.7; MØ: 90; GL: 129.7; sworze tłokowy: 46x105; Liczba piercieni: 3 RTK T15 3.5 CR G6 M 3 DSF 5 CR → 80 00155 1 0 ...
---	-------------------	--







	80 00155 1 0 000	Ø128; STD; Zestaw: 1; [T15 G6 CR 3.5] [M 3] [DSF CR 5]
	80 00717 1 0 000	Ø128; STD; Zestaw: 1; [T15 G6 CK 4] [M G3 3] [DSF CR 4]

	41 000 960	tłoki: 41000600; tuleja cylindrowa: 89092120
	42 043 960	tłoki: 42043600; tuleja cylindrowa: 89092120

	89 092 120	N - Mokra tuleja cylindra; skoczony; A=144.5 C=153.8 L=253 H+F=10.05+1
---	-------------------	--

	78 693 600	[para] HL STD Ø 104.000 / 111.000 / 30.500 / 3.472 St/B/G1 78 693 610 0,25 / 78 693 620 0,50 / 78 693 630 0,75 / 78 693 640 1,00
	78 694 604	[para] PASS-L STD Ø 104.000 / 111.000 / 37.810 / 3.474 St/B/G 78 694 614 0,25 / 78 694 624 0,50 / 78 694 634 0,75 / 78 694 644 1,00



cont...

	20 0602 G2801	Długo: 256; rednica otworu lepego duej główki korbowodu: 95; rednica małej główki korbowodu: 46; Szeroko stopy korbowodu: 33; Szeroko tła korbowodu: 39; korbowód trapezowy; krakowany
	20 0302 28420	bez tulei cylindra
	20 0802 G2820 20 0802 G2828	- V - G - S - - - - -; element gotowy do montau, Uywaj do wiecy zapłonowej M14 - V - G - S - - - - -; element gotowy do montau
	25311	EX; 51 x 12 x 142.5 x l/S - Cr - 30° - VS - 1 - III
	25310 92-25004 92-25018 92-25005	IN; 58 x 12 x 142.5 x l/S - Cr - 30° - VS - 1 - III EX; 53.1 x 43 x 7.45; G2; 30° EX; 53.11 x 43 x 9.5; HWR IN; 61.11 x 49 x 6.8; G2; 30°
	92-25019 20 1403 44300	IN; 61.11 x 49 x 8.8; HWR

	81-25103	EX; 18/ x 12 x 70 G2, Długo rowka olejowego jest róna w zalenoci od główicy! 81-25103 ma krótki rowek olejowy. Dopiero po wymontowaniu przewodnicy zaworu mona stwierdzi jej wersj. Nie mona odróni wersji po numerach silnika.
	81-25113	EX; 18/ x 12.01 x 70 G2
	81-25102	EX; 18/ x 12.02 x 56 G2
	81-25101	IN; 18/ x 12.02 x 59.5 G2
	81-2536	IN/EX; 18/ x 12 x 64 G2, W przypadku stosowania gazu uywa tylko w obszarze dolotu.

E

8		128	E2842LE322	G	LA	12	21915 cm ³	4V	400 kW	544 PS		142
----------	---	------------	-------------------	---	----	----	-----------------------	----	--------	--------	---	-----



























	40 208 600	Ø cylindra: 128; KH: 80.7; MT: -28.2; MØ: 94; GL: 129.7; sworze tłokowy: 46x105; Liczba piercieni: 3 RTK T15 3.5 CR G6 M 3 DSF 5 CR → 80 00155 1 0 ...
	41 000 600	Ø cylindra: 128; KH: 80.7; MT: -26; MØ: 91.6; GL: 129.7; sworze tłokowy: 46x105; Liczba piercieni: 3 RTK T15 4 CK G6 M 3 CR G3 DSF 4 CR → 80 01100 1 0 ...

	80 00155 1 0 000	Ø128; STD; Zestaw: 1; [T15 G6 CR 3.5] [M 3] [DSF CR 5]
	80 00717 1 0 000	Ø128; STD; Zestaw: 1; [T15 G6 CK 4] [M G3 3] [DSF CR 4]
	80 01100 1 0 000	Ø128; STD; Zestaw: 1; [T15 G6 CK 4] [M G3 CR 3] [DSF CR 4]



	89 092 120	N - Mokra tuleja cylindra; skoczony; A=144.5 C=153.8 L=253 H+F=10.05+1
---	-------------------	--

	78 693 600	[para] HL STD Ø 104.000 / 111.000 / 30.500 / 3.472 St/B/G1 78 693 610 0,25 / 78 693 620 0,50 / 78 693 630 0,75 / 78 693 640 1,00
	78 694 604	[para] PASS-L STD Ø 104.000 / 111.000 / 37.810 / 3.474 St/B/G 78 694 614 0,25 / 78 694 624 0,50 / 78 694 634 0,75 / 78 694 644 1,00
	78 897 600	[para] PL STD Ø 90.000 / 95.000 / 31.000 / 2.473 St/B/S; PL STD Ø 90.000 / 95.000 / 31.000 / 2.473 St/B/G1 78 897 605 0,10 / 78 897 610 0,25 / 78 897 620 0,50 / 78 897 630 0,75 / 78 897 640 1,00 , Górna panewka jest oznakowana 'SPUTTER'.
	79 443 600	[para] PL STD Ø 90.000 / 95.000 / 31.000 / 2.473 St/B/S, SPUTTER: u góry i u dołu, zastosowanie GAS
	87 346 690	[komplet] PL-B SEMI Ø 46.000 / 50.600 / 38.700 / St/B
	87 366 600	[komplet] NW-L STD Ø 69.940 / 76.000 / 35.000 / 3.000 St/B; NW-L STD Ø 69.940 / 75.000 / 28.000 / 2.500 St/A

cont...

87 397 604	[komplet] HL STD Ø 104.000 / 111.000 / 30.500 / 3.472 St/B/G1; PASS-L STD Ø 104.000 / 111.000 / 37.810 / 3.474 St/B/G 87 397 614 0,25 / 87 397 624 0,50		
 20 0302 28420	bez tulei cylindra		
 20 0802 G2840	- V - G - S - - - - ; element gotowy do montau, Uywaj do wiecy zapłonowej M14		
 25311 25324	EX; 51 x 12 x 142.5 x I/S - Cr - 30° - VS - 1 - III EX; 51 x 12 x 142.5 x RA/S - Cr - 30° - 1 - III	 81-25101 81-2536	IN; 18/ x 12.02 x 59.5 G2 IN/EX; 18/ x 12 x 64 G2, W przypadku stosowania gazu uywa tylko w obszarze dolotu.
25310	IN; 58 x 12 x 142.5 x I/S - Cr - 30° - VS - 1 - III	 92-25004 92-25018 92-25005 92-25019	EX; 53.1 x 43 x 7.45; G2; 30° EX; 53.11 x 43 x 9.5; HWR IN; 61.11 x 49 x 6.8; G2; 30° IN; 61.11 x 49 x 8.8; HWR
 20 1403 44300			
9	 128		
 E2848LE322	PATRUUS	G LA 8 14618 cm ³ 4V 250 kW 340 PS	 142
 41 000 600	 	Ø cylindra: 128; KH: 80.7; MT: -26; MØ: 91.6; GL: 129.7; sworze tłokowy: 46x105; Liczba piercieni: 3 RTK T15 4 CK G6 M 3 CR G3 DSF 4 CR → 80 01100 1 0 ...	
 42 043 600		Ø cylindra: 128; KH: 80.7; MT: -21.7; MØ: 90; GL: 129.7; sworze tłokowy: 46x105; Liczba piercieni: 3 RTK T15 3.5 CR G6 M 3 DSF 5 CR	
 80 01100 1 0 000		Ø128; STD; Zestaw: 1; [T15 G6 CK 4] [M G3 CR 3] [DSF CR 4]	
 41 000 960		tłoki: 41000600; tuleja cylindrowa: 89092120	
 42 043 960		tłoki: 42043600; tuleja cylindrowa: 89092120	
 89 092 120		N - Mokra tuleja cylindra; skoczony; A=144.5 C=153.8 L=253 H+F=10.05+1	
 78 693 600		[para] HL STD Ø 104.000 / 111.000 / 30.500 / 3.472 St/B/G1 78 693 610 0,25 / 78 693 620 0,50 / 78 693 630 0,75 / 78 693 640 1,00	
 78 694 604		[para] PASS-L STD Ø 104.000 / 111.000 / 37.810 / 3.474 St/B/G 78 694 614 0,25 / 78 694 624 0,50 / 78 694 634 0,75 / 78 694 644 1,00	
 78 897 600		[para] PL STD Ø 90.000 / 95.000 / 31.000 / 2.473 St/B/S; PL STD Ø 90.000 / 95.000 / 31.000 / 2.473 St/B/G1 78 897 605 0,10 / 78 897 610 0,25 / 78 897 620 0,50 / 78 897 630 0,75 / 78 897 640 1,00, Górna panewka jest oznakowana 'SPUTTER'.	
 79 443 600		[para] PL STD Ø 90.000 / 95.000 / 31.000 / 2.473 St/B/S, SPUTTER: u góry i u dołu, zastosowanie GAS	
 87 385 600		[komplet] NW-L STD Ø 69.940 / 76.000 / 35.000 / 3.000 St/B; NW-L STD Ø 69.940 / 75.000 / 28.000 / 2.500 St/A	
 87 401 604		[komplet] HL STD Ø 104.000 / 111.000 / 30.500 / 3.472 St/B/G1; PASS-L STD Ø 104.000 / 111.000 / 37.810 / 3.474 St/B/G 87 401 614 0,25 / 87 401 624 0,50 / 87 401 634 0,75 / 87 401 644 1,00	
 20 0602 G2801		Długo: 256; rednica otworu lepego duej główki korbowodu: 95; rednica malej główki korbowodu: 46; Szeroko stopy korbowodu: 33; Szeroko łba korbowodu: 39; korbowód trapezowy; krakowany	
 20 0302 25380		bez tulei cylindra	
 20 0802 G2820 20 0802 G2828		- V - G - S - - - - ; element gotowy do montau, Uywaj do wiecy zapłonowej M14 - V - G - S - - - - ; element gotowy do montau	

cont..

	25311	EX; 51 x 12 x 142.5 x I/S - Cr - 30° - VS - 1 - III		81-25103	EX; 18/ x 12 x 70 G2, Długo rowka olejowego jest różna w zależności od głowicy! 81-25103 ma krótki rowek olejowy. Dopiero po wymontowaniu przewodnicy zaworu można stwierdzić jej wersję. Nie można odróżnić wersji po numerach silnika.
	25310	IN; 58 x 12 x 142.5 x I/S - Cr - 30° - VS - 1 - III		81-25113	EX; 18/ x 12.01 x 70 G2
	92-25004	EX; 53.1 x 43 x 7.45; G2; 30°		81-25102	EX; 18/ x 12.02 x 56 G2
	92-25018	EX; 53.11 x 43 x 9.5; HWR		81-25101	IN; 18/ x 12.02 x 59.5 G2
	92-25005	IN; 61.11 x 49 x 6.8; G2; 30°		81-2536	IN/EX; 18/ x 12 x 64 G2, W przypadku stosowania gazu używać tylko w obszarze dolotu.
	92-25019	IN; 61.11 x 49 x 8.8; HWR			



10 128

E2876E312

G 6 12816 cm³ 4V 140 kW 190 PS 12,0:1 166



PATRUUS



41 260 600 Ø cylindra: 128; KH: 78.65; MT: -26.6; MØ: 93; GL: 133.65; sworze tłokowy: 50x107; Liczba pierścieni: 3
RTK
T15 4 CK G6
M 3 CR G3
DSF 4 CR
→ **80 01100 1 0 ...**



80 00155 1 0 000 Ø128; STD; Zestaw: 1; [T15 G6 CR 3.5] [M 3] [DSF CR 5]

80 00300 1 0 000 Ø128; STD; Zestaw: 1; [T15 G6 CR 4] [M 3] [DSF CR 4]

80 01100 1 0 000 Ø128; STD; Zestaw: 1; [T15 G6 CK 4] [M G3 CR 3] [DSF CR 4]



41 260 960 tłoki: 41260600; tuleja cylindrowa: 89186120



89 186 120 N - Mokra tuleja cylindra; skoczony; A=144.5 C=153.8 L=270 H+F=10.07+1

89 914 120 N - Mokra tuleja cylindra; skoczony; A=144.5 C=153.8 L=270 H+F=10.07+1, płaszcz wodny powłok. plazmowo



78 586 600 [para] HL STD Ø 104.000 / 111.000 / 36.000 / 3.478 St/B/G1
78 586 605 0,10 / 78 586 610 0,25 / 78 586 620 0,50 / 78 586 630 0,75

79 237 600 [para] PL STD Ø 90.000 / 95.000 / 36.200 / 2.478 St/B/G1; PL STD Ø 90.000 / 95.000 / 36.200 / 2.479 St/B/S
79 237 610 0,25 / 79 237 620 0,50 / 79 237 630 0,75, Górna panewka jest oznakowana 'SPUTTER'.

79 261 600 [para] AS STD Ø 114.750 / 137.650 // 3.400 St/A
79 261 610 0,40 / 79 261 620 0,80

79 444 600 [para] PL STD Ø 90.000 / 95.000 / 36.200 / 2.479 St/B/S, SPUTTER: u góry i u dołu, zastosowanie GAS

77 682 600 [komplet] HL STD Ø 104.000 / 111.000 / 36.000 / 3.478 St/B/G1
77 682 610 0,25 / 77 682 620 0,50

77 682 700 [komplet] HL STD Ø 104.000 / 111.500 / 36.000 / 3.728 St/B/G1
77 682 710 0,25, Nadwymiar zewnętrzny + 0,50 mm



20 0602 G2876 Długo: 256; rednica otworu lepego dnej głowki korbowodu: 95; rednica małej głowki korbowodu: 50.06; Szeroko stopy korbowodu: 45.85; Szeroko łba korbowodu: 39; korbowód trapezowy; krakowany



20 0502 28760 rednica kołnierza koła zamachowego: 113



20 0302 28661 bez tulei cylindra



20 0802 G2840 - V - G - S - - - -; element gotowy do montau, Uywaj do wiecy zapłonowej M14



25311 EX; 51 x 12 x 142.5 x I/S - Cr - 30° - VS - 1 - III

25310 IN; 58 x 12 x 142.5 x I/S - Cr - 30° - VS - 1 - III



92-25004 EX; 53.1 x 43 x 7.45; G2; 30°

92-25018 EX; 53.11 x 43 x 9.5; HWR

92-25005 IN; 61.11 x 49 x 6.8; G2; 30°

92-25019 IN; 61.11 x 49 x 8.8; HWR



























81-25102 EX; 18/ x 12.02 x 56 G2

















81-25101 IN; 18/ x 12.02 x 59.5 G2

81-2536 IN/EX; 18/ x 12 x 64 G2, W przypadku stosowania gazu używać tylko w obszarze dolotu.

cont...





	20 1002 G2866									
	20 1402 28760									
11		128								
	E2876LE302		G	LA	6	12816 cm ³	4V	190 kW	258 PS	
	PATRUUS								 166	
	40 207 600		Ø cylindra: 128; KH: 78.65; MT: -25.3; MØ: 105.8; GL: 133.65; sworze tłokowy: 50x107; Liczba piercieni: 3							
			RTK							
			T15 3.5 CR G6							
			M 3							
			DSF 5 CR							
			→ 80 00155 1 0 ...							
	41 498 600		Ø cylindra: 128; KH: 78.65; VT1: -5; MT: -24.8; MØ: 102; GL: 133.65; sworze tłokowy: 50x107; Liczba piercieni: 3							
			RTK							
			T15 4 CR G6							
			M 3							
			DSF 4 CR							
			→ 80 00300 1 0 ...							
	80 00155 1 0 000	Ø128; STD; Zestaw: 1; [T15 G6 CR 3.5] [M 3] [DSF CR 5]								
	80 00300 1 0 000	Ø128; STD; Zestaw: 1; [T15 G6 CR 4] [M 3] [DSF CR 4]								
	40 207 960	tłoki: 40207600; tuleja cylindrowa: 89186120								
	40 207 961	tłoki: 40207600; tuleja cylindrowa: 89324120								
	40 207 963	tłoki: 40207600; tuleja cylindrowa: 89518120								
	40 207 964	tłoki: 40207600; tuleja cylindrowa: 89534120								
	41 498 960	tłoki: 41498600; tuleja cylindrowa: 89186120								
	89 186 120	N - Mokra tuleja cylindra; skoczony; A=144.5 C=153.8 L=270 H+F=10.07+1								
	89 914 120	N - Mokra tuleja cylindra; skoczony; A=144.5 C=153.8 L=270 H+F=10.07+1, płaszcz wodny powlek. plazmowo								
	89 518 120	N - Mokra tuleja cylindra; skoczony; A=144.5 C=153.8 L=270 H+F=10.27+1								
	89 324 120	N - Mokra tuleja cylindra; skoczony; A=144.5 C=153.8 L=270 H+F=10.57+1								
	89 892 120	N - Mokra tuleja cylindra; skoczony; A=145.5 C=154.3 L=270 H+F=10.07+1								
	78 586 600	[para] HL STD Ø 104.000 / 111.000 / 36.000 / 3.478 St/B/G1 78 586 605 0,10 / 78 586 610 0,25 / 78 586 620 0,50 / 78 586 630 0,75								
	79 237 600	[para] PL STD Ø 90.000 / 95.000 / 36.200 / 2.478 St/B/G1; PL STD Ø 90.000 / 95.000 / 36.200 / 2.479 St/B/S 79 237 610 0,25 / 79 237 620 0,50 / 79 237 630 0,75, Górna panewka jest oznakowana 'SPUTTER'.								
	79 261 600	[para] AS STD Ø 114.750 / 137.650 / / 3.400 St/A 79 261 610 0,40 / 79 261 620 0,80								
	79 444 600	[para] PL STD Ø 90.000 / 95.000 / 36.200 / 2.479 St/B/S, SPUTTER: u góry i u dołu, zastosowanie GAS								
	77 682 600	[komplet] HL STD Ø 104.000 / 111.000 / 36.000 / 3.478 St/B/G1 77 682 610 0,25 / 77 682 620 0,50								
	77 682 700	[komplet] HL STD Ø 104.000 / 111.500 / 36.000 / 3.728 St/B/G1 77 682 710 0,25, Nadwymiar zewnętrzny + 0,50 mm								
	20 0602 G2876	Długo: 256; rednica otworu lepego duej główki korbowodu: 95; rednica malej główki korbowodu: 50.06; Szeroko stopy korbowodu: 45.85; Szeroko łba korbowodu: 39; korbowód trapezowy; krakowany								
	20 0502 28760	rednica kołnierza koła zamachowego: 113								
	20 0302 28661	bez tulei cylindra								
	20 0802 G2820	- V - G - S - - - - -; element gotowy do montau, Uzywaj do wiecej zaplonowej M14								
	20 0802 G2828	- V - G - S - - - - -; element gotowy do montau								
	25311	EX; 51 x 12 x 142.5 x I/S - Cr - 30° - VS - 1 - III					81-25103	EX; 18/ x 12 x 70 G2, Długo rowka olejowego jest różna w zalenoci od główicy! 81-25103 ma krótki rowek olejowy. Dopiero po wymontowaniu przewodnicy zaworu mona stwierdzi jej wersj. Nie mona odróni wersji po numerach silnika.		
	25310	IN; 58 x 12 x 142.5 x I/S - Cr - 30° - VS - 1 - III					81-25113	EX; 18/ x 12.01 x 70 G2		

cont...



	92-25004	EX; 53.1 x 43 x 7.45; G2; 30°	81-25101	IN; 18/ x 12.02 x 59.5 G2
	92-25018	EX; 53.11 x 43 x 9.5; HWR	81-2536	IN/EX; 18/ x 12 x 64 G2, W przypadku stosowania gazu uywa tylko w obszarze dolotu.
	92-25005	IN; 61.11 x 49 x 6.8; G2; 30°		
	92-25019	IN; 61.11 x 49 x 8.8; HWR		
	20 1002 G2866			
	20 1402 28760			
12		128		
	E2876LE302		G LA 6 12816 cm ³ 4V 200 kW 272 PS	 166
	40 207 600	Ø cylindra: 128; KH: 78.65; MT: -25.3; MØ: 105.8; GL: 133.65; sworze tłokowy: 50x107; Liczba pierścieni: 3 RTK T15 3.5 CR G6 M 3 DSF 5 CR → 80 00155 1 0 ...		
	41 498 600	Ø cylindra: 128; KH: 78.65; VT1: -5; MT: -24.8; MØ: 102; GL: 133.65; sworze tłokowy: 50x107; Liczba pierścieni: 3 RTK T15 4 CR G6 M 3 DSF 4 CR → 80 00300 1 0 ...		
	80 00155 1 0 000	Ø128; STD; Zestaw: 1; [T15 G6 CR 3.5] [M 3] [DSF CR 5]		
	80 00300 1 0 000	Ø128; STD; Zestaw: 1; [T15 G6 CR 4] [M 3] [DSF CR 4]		
	40 207 960	tłoki: 40207600; tuleja cylindrowa: 89186120		
	40 207 961	tłoki: 40207600; tuleja cylindrowa: 89324120		
	40 207 963	tłoki: 40207600; tuleja cylindrowa: 89518120		
	40 207 964	tłoki: 40207600; tuleja cylindrowa: 89534120		
	41 498 960	tłoki: 41498600; tuleja cylindrowa: 89186120		
	89 186 120	N - Mokra tuleja cylindra; skoczony; A=144.5 C=153.8 L=270 H+F=10.07+1		
	89 914 120	N - Mokra tuleja cylindra; skoczony; A=144.5 C=153.8 L=270 H+F=10.07+1, płaszcz wodny powlek. plazmowo		
	89 518 120	N - Mokra tuleja cylindra; skoczony; A=144.5 C=153.8 L=270 H+F=10.27+1		
	89 324 120	N - Mokra tuleja cylindra; skoczony; A=144.5 C=153.8 L=270 H+F=10.57+1		
	89 892 120	N - Mokra tuleja cylindra; skoczony; A=145.5 C=154.3 L=270 H+F=10.07+1		
	78 586 600	[para] HL STD Ø 104.000 / 111.000 / 36.000 / 3.478 St/B/G1 78 586 605 0,10 / 78 586 610 0,25 / 78 586 620 0,50 / 78 586 630 0,75		
	79 237 600	[para] PL STD Ø 90.000 / 95.000 / 36.200 / 2.478 St/B/G1; PL STD Ø 90.000 / 95.000 / 36.200 / 2.479 St/B/S 79 237 610 0,25 / 79 237 620 0,50 / 79 237 630 0,75 , Górna panewka jest oznakowana 'SPUTTER'.		
	79 261 600	[para] AS STD Ø 114.750 / 137.650 // / 3.400 St/A 79 261 610 0,40 / 79 261 620 0,80		
	79 444 600	[para] PL STD Ø 90.000 / 95.000 / 36.200 / 2.479 St/B/S, SPUTTER: u góry i u dołu, zastosowanie GAS		
	77 682 600	[komplet] HL STD Ø 104.000 / 111.000 / 36.000 / 3.478 St/B/G1 77 682 610 0,25 / 77 682 620 0,50		
	77 682 700	[komplet] HL STD Ø 104.000 / 111.500 / 36.000 / 3.728 St/B/G1 77 682 710 0,25 , Nadwymiar zewnętrzny + 0,50 mm		
	87 501 600	[komplet] NW-L STD Ø 69.940 / 76.000 / 39.000 / 3.000 St/B; NW-L STD Ø 69.940 / 75.000 / 36.000 / 2.500 St/A; NW-L STD Ø 69.940 / 75.000 / 28.000 / 2.500 St/A		
	20 0602 G2876	Długo: 256; rednica otworu lepego duej główki korbowodu: 95; rednica malej główki korbowodu: 50.06; Szeroko stopy korbowodu: 45.85; Szeroko łba korbowodu: 39; korbowód trapezowy; krakowany		
	20 0502 28760	rednica kołnierza koła zamachowego: 113		
	20 0302 28661	bez tulei cylindra		
	20 0802 G2840	- V - G - S - - - - -; element gotowy do montau, Uywjaj do wiecy zapłonowej M14		

cont...

ENERGIE 2G

	25311	EX; 51 x 12 x 142.5 x I/S - Cr - 30° - VS - 1 - III		81-25101	IN; 18/ x 12.02 x 59.5 G2
	25324	EX; 51 x 12 x 142.5 x RA/S - Cr - 30° - 1 - III		81-2536	IN/EX; 18/ x 12 x 64 G2, W przypadku stosowania gazu używa tylko w obszarze dolotu.
	25310	IN; 58 x 12 x 142.5 x I/S - Cr - 30° - VS - 1 - III		92-25004	EX; 53.1 x 43 x 7.45; G2; 30°
				92-25018	EX; 53.11 x 43 x 9.5; HWR
				92-25005	IN; 61.11 x 49 x 6.8; G2; 30°
				92-25019	IN; 61.11 x 49 x 8.8; HWR
	20 1002 G2866				
	20 1402 28760				

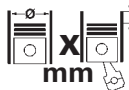
E

	Cyl.	 mm	cm ³		Comp. Ratio ε	kW	PS	Pos
F4BE0611A Euro 5	G (LA) 6	102 x 120	5883	12	11.0	147	200	1
F4BE0611A Euro 5	G (LA) 6	102 x 120	5900	12	11	147	200	1

1



102



F4BE0611A Euro 5

09.2006 → 09.2015

G LA 6

5883 cm³

12V 147 kW

200 PS

⊗ 11.0

⊗ 120

F4BE0611A Euro 5

G LA 6

5900 cm³

12V 147 kW

200 PS

⊗ 11

⊗ 120









EURO CARGO I-III

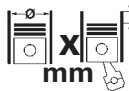

42 352 600

∅ cylindra: 102; KH: 71.38; MT: -23.86; M∅: 84.9; GL: 105.38
RTK, KKK

									
	Cyl.	mm							cm ³
G934	G	4	122 x 150	7000	4	13,0:1	145	197	1
G936	G	6	122 x 150	10500	4	13,0:1	217	295	1
G944	G	4	130 x 150	8000	4	13,0:1	164	223	2
G946	G	6	130 x 150	12000	4	13,0:1	246	334	3
G9508	G	8	130 x 157	16700	4	13,3:1	344	468	4
G9512	G	12	130 x 157	25000	4	13,3:1	516	702	5

L

1		122	G934	G	4	7000 cm ³	4V	145 kW	197 PS	ξ 13,0:1	150
			G936	G	6	10500 cm ³	4V	217 kW	295 PS	ξ 13,0:1	150



81-23001 IN/EX; 15.03/20 x 9.01 x 64 G2



92-23002 EX; 40.04 x 30.95 x 7.6; ; 30°

92-23001 IN; 45.05 x 34.7 x 8.08; G6; 20°

2		130	G944	G	4	8000 cm ³	4V	164 kW	223 PS	ξ 13,0:1	150
----------	--	------------	-------------	---	---	----------------------	----	--------	--------	----------	-----



89 958 110 N - Mokra tuleja cylindra; skoczony; A=145 C=157.9 L=235 H=12



81-23001 IN/EX; 15.03/20 x 9.01 x 64 G2



92-23002 EX; 40.04 x 30.95 x 7.6; ; 30°

92-23001 IN; 45.05 x 34.7 x 8.08; G6; 20°

3		130	G946	G	6	12000 cm ³	4V	246 kW	334 PS	ξ 13,0:1	150
----------	--	------------	-------------	---	---	-----------------------	----	--------	--------	----------	-----



89 958 110 N - Mokra tuleja cylindra; skoczony; A=145 C=157.9 L=235 H=12



105-46001 EX; 39 x 9 x 157 x RA/S - Cr - 30° - VS - 22 -



MK-9H stoek zaworu; Liczba karbów: 3; rednica trzonka zaworu: 9

105-46000 IN; 43.5 x 9 x 157.2 x RA/S - Cr - 20° - VS - 22 - III



81-23001 IN/EX; 15.03/20 x 9.01 x 64 G2



92-23002 EX; 40.04 x 30.95 x 7.6; ; 30°

92-23001 IN; 45.05 x 34.7 x 8.08; G6; 20°

L

4		130	G9508	G	8	16700 cm ³	4V	344 kW	468 PS	ξ 13,3:1	157
----------	--	------------	--------------	---	---	-----------------------	----	--------	--------	----------	-----



89 959 110 N - Mokra tuleja cylindra; skoczony; A=149.5 C=163.4 L=262 H=10.06



81-23002 IN/EX; 15.03/17.5 x 9.01 x 62 G2

5		130	G9512	G	12	25000 cm ³	4V	516 kW	702 PS	ξ 13,3:1	157
----------	--	------------	--------------	---	----	-----------------------	----	--------	--------	----------	-----



89 959 110 N - Mokra tuleja cylindra; skoczony; A=149.5 C=163.4 L=262 H=10.06



105-35671 EX; 41 x 9 x 153.7 x RA/S - Cr - 30° - VS - 22 - III





MK-9H stoek zaworu; Liczba karbów: 3; rednica trzonka zaworu: 9

105-35670 IN; 44 x 9 x 153.7 x RA/S - Cr - 20° - VS - 22 - III

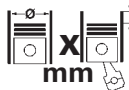

81-23002 IN/EX; 15.03/17.5 x 9.01 x 62 G2

















		Cyl.		 mm	cm ³		Comp. Ratio ϵ	kW	PS	Pos
E 0824	E 302	G	4	108 x 125	4580	2				6
E 0826	E 302	G	6	108 x 120	6596	2				7
E 0834	E 312	G (NA)	4	108 x 125	4580	8	13.0	37-53	50-72	2
E 0834	E 302	G (NA)	4	108 x 125	4580	8	13.0	54-62	73-84	1
E 0834	LE 302	G (LA)	4	108 x 125	4580	8	11.0	68	92	3
E 0836	E 302, E 312	G (NA)	6	108 x 125	6871	12	13.0	56-85	76-116	4
E 0836	LE 202	G (LA)	6	108 x 125	6871	12	11.0	110	150	5
E 2676	E 302	G (NA)	6	126 x 166	12419	24	12.0	140-160	190-218	8
E 2676	LE 202, LE 212	G (LA)	6	126 x 166	12419	24	19.0	220-250	299-340	9
E 2842	LE 302	G (LA)	12	128 x 142	21930	2				23
E 2842	LE 302	G (LA)	12	128 x 142	21930	2				24
E 2842	LE 202	G (LA)	12	128 x 142	21930	2				22
E 2842	E	G	12	128 x 142	21930	2		177	241	21
E 2842	LE 202, LE 302	G (LA)	12	128 x 142	21927	24	12.0	360-420	489-571	10
E 2842	LE 312	G (LA)	12	128 x 142	21927	24	12.0	360-420	490-571	11
E 2842	LE 322	G (LA)	12	128 x 142	21927	24	12.0	380-420	517-571	12
E 2848	LE 322	G (LA)	8	128 x 142	14618	16	12.0	265-295	360-401	13
E 2876	TE 302	G (A)	6	128 x 166	12816	12	12.0	130	177	19
E 2876 KAT	E 302	G	6	128 x 166	12816	2		130-140	177-190	14
E 2876	E 312	G (LA)	6	128 x 166	12816	12	12.0	150-170	204-231	14
E 2876	LE 302	G (LA)	6	128 x 166	12816	12	11.0	200-210	272-286	16
E 2876	LE 202	G (LA)	6	128 x 166	12816	12	12.0	220	299	15
E 2876 Euro 5	LUH 01	G (LA)	6	128 x 166	12816	12	12.0	228	310	17
E 2876 Euro 5	LUH 02	G (LA)	6	128 x 166	12816	12	12.0	228	310	18
E 3262	E 302, LE 242	G (NA)	12	132 x 157	25782	48	12.0	275-580	374-789	25
E 3262	LE 232	G	1	132 x 157	25782	48	12	450	612	27
E 3262	LE 232	G (NA)	12	132 x 157	25782	48	12.0	450-580	612-789	29
E 3262	LE 222	G (NA)	12	132 x 157	25782	48	12.0	500	680	26
E 3262	LE 202, LE 212, LE 222	G	12	132 x 157	25782	48	12	500-580	680-789	27
E 3262	E 203	G	12	132 x 157	25782	4	12:1	550	748	25
E 3262	LE 202	G (LA)	12	132 x 157	25782	48	12.0	550-580	748-789	26
E 3262	LE 212	G (NA)	12	132 x 157	25782	48	12.0	550-580	748-789	28
E 3268	LE 232	G (LA)	8	132 x 157	17188	16	12	370	503	27
E 3268	LE 212	G (LA)	1	132 x 157	17188	16	12	370-390	503-530	26
E 3268	LE 212, LE 222, LE 222, LE 232	G (LA)	8	132 x 157	17188	16		370-530	503-530	26
G 2876	DUH 02	G (NA)	6	128 x 166	12816	12	10.0	200	272	20
G 2876 Euro 5	DUH 01	G (NA)	6	128 x 166	12816	12	10.0	200	272	20

M



1 <div style="display: flex; align-items: center;"> 108 </div>	
<div style="display: flex; justify-content: space-between;"> E 0834 E 302 </div>	
<div style="display: flex; justify-content: space-between; font-size: 12px;"> G NA 4 4580 cm³ 8V 54-62 kW 73-84 PS € 13.0 125 </div>	
<p>41 259 600</p>	<p>Ø cylindra: 108; KH: 62.8; MT: -14.9; MØ: 84.6; GL: 102; sworze tłokowy: 42x86; Liczba piercieni: 3</p> <p>RTK</p> <p>R 2.5 CR G3</p> <p>M 2.5</p> <p>DSF 4 CR</p>
<p>89 470 191 89 470 190</p>	<p>T - Sucha tuleja cylindra; semi; A=111.27 L=217</p> <p>T - Sucha tuleja cylindra; semi; A=111.6 C=116 L=218 H=5.04</p>
<p>89 470 110 89 453 110</p>	<p>T - Sucha tuleja cylindra; skoczony; A=111.49 C=116 L=217 H=4.04</p> <p>T - Sucha tuleja cylindra; skoczony; A=111.99 C=116 L=217 H=4.04, Nadwymiar zewnętrzny + 0,50 mm</p>
<p>79 234 600</p>	<p>[para] HL STD Ø 77.000 / 82.000 / 26.000 / 2.480 St/B/G</p> <p>79 234 610 0,25 / 79 234 620 0,50</p>
<p>79 299 600 79 333 600</p>	<p>[para] AS STD Ø 84.850 / 102.450 // 2.900 St/A</p> <p>[para] PL STD Ø 70.000 / 74.000 / 27.000 / 1.987 St/B/S; PL STD Ø 70.000 / 74.000 / 27.000 / 1.987 St/B/G</p> <p>79 333 610 0,25, Górna panewka jest oznakowana 'SPUTTER'.</p>
<p>79 445 600 77 743 600 77 805 600</p>	<p>[para] PL STD Ø 70.000 / 74.000 / 27.000 / 1.987 St/B/S, SPUTTER: u góry i u dołu, zastosowanie GAS</p> <p>[komplet] HL STD Ø 77.000 / 82.000 / 26.000 / 2.480 St/B/G</p> <p>[komplet] PL STD Ø 70.000 / 74.000 / 27.000 / 1.987 St/B/S; PL STD Ø 70.000 / 74.000 / 27.000 / 1.987 St/B/G, Górna panewka jest oznakowana 'SPUTTER'.</p>
<p>77 808 600 77 927 690</p>	<p>[komplet] NW-L STD Ø 54.940 / 59.000 / 25.000 / 2.000 St/B</p> <p>[komplet] PL-B SEMI Ø 42.000 / 46.000 / 35.250 / St/B</p>
<p>20 0502 08343</p>	
<p>81-25104 81-25105</p>	<p>EX; 16.03/ x 10.02 x 55 G2</p> <p>IN; 16.03/ x 10.02 x 60 G2</p>
<p>92-25023 92-25022</p>	<p>EX; 44.1 x 34.9 x 8.15; G2</p> <p>IN; 51.1 x 41.6 x 7.45; G2</p>
<p>20 1002 08341</p>	
<p>20 1402 08340</p>	

M

2 <div style="display: flex; align-items: center;"> 108 </div>	
<div style="display: flex; justify-content: space-between;"> E 0834 E 312 </div>	
<div style="display: flex; justify-content: space-between; font-size: 12px;"> G NA 4 4580 cm³ 8V 37-53 kW 50-72 PS € 13.0 125 </div>	
<p>41 259 600</p>	<p>Ø cylindra: 108; KH: 62.8; MT: -14.9; MØ: 84.6; GL: 102; sworze tłokowy: 42x86; Liczba piercieni: 3</p> <p>RTK</p> <p>R 2.5 CR G3</p> <p>M 2.5</p> <p>DSF 4 CR</p>
<p>79 234 600</p>	<p>[para] HL STD Ø 77.000 / 82.000 / 26.000 / 2.480 St/B/G</p> <p>79 234 610 0,25 / 79 234 620 0,50</p>
<p>79 299 600 79 333 600</p>	<p>[para] AS STD Ø 84.850 / 102.450 // 2.900 St/A</p> <p>[para] PL STD Ø 70.000 / 74.000 / 27.000 / 1.987 St/B/S; PL STD Ø 70.000 / 74.000 / 27.000 / 1.987 St/B/G</p> <p>79 333 610 0,25, Górna panewka jest oznakowana 'SPUTTER'.</p>
<p>79 445 600 77 743 600 77 805 600</p>	<p>[para] PL STD Ø 70.000 / 74.000 / 27.000 / 1.987 St/B/S, SPUTTER: u góry i u dołu, zastosowanie GAS</p> <p>[komplet] HL STD Ø 77.000 / 82.000 / 26.000 / 2.480 St/B/G</p> <p>[komplet] PL STD Ø 70.000 / 74.000 / 27.000 / 1.987 St/B/S; PL STD Ø 70.000 / 74.000 / 27.000 / 1.987 St/B/G, Górna panewka jest oznakowana 'SPUTTER'.</p>
<p>77 808 600 77 927 690</p>	<p>[komplet] NW-L STD Ø 54.940 / 59.000 / 25.000 / 2.000 St/B</p> <p>[komplet] PL-B SEMI Ø 42.000 / 46.000 / 35.250 / St/B</p>
<p>20 0502 08343</p>	
<p>81-25104 81-25105</p>	<p>EX; 16.03/ x 10.02 x 55 G2</p> <p>IN; 16.03/ x 10.02 x 60 G2</p>
<p>92-25023 92-25022</p>	<p>EX; 44.1 x 34.9 x 8.15; G2</p> <p>IN; 51.1 x 41.6 x 7.45; G2</p>
<p>20 1002 08341</p>	
<p>20 1402 08340</p>	

3		108	
E 0834		LE 302	
		G	LA 4 4580 cm ³ 8V 68 kW 92 PS €11.0 125
	41 259 600	Ø cylindra: 108; KH: 62.8; MT: -14.9; MØ: 84.6; GL: 102; sworze tłokowy: 42x86; Liczba pierścieni: 3 RTK R 2.5 CR G3 M 2.5 DSF 4 CR	
	89 470 110	T - Sucha tuleja cylindra; skoczony; A=111.49 C=116 L=217 H=4.04	
	79 234 600	[para] HL STD Ø 77.000 / 82.000 / 26.000 / 2.480 St/B/G 79 234 610 0,25 / 79 234 620 0,50	
	79 299 600	[para] AS STD Ø 84.850 / 102.450 // 2.900 St/A	
	79 333 600	[para] PL STD Ø 70.000 / 74.000 / 27.000 / 1.987 St/B/S; PL STD Ø 70.000 / 74.000 / 27.000 / 1.987 St/B/G 79 333 610 0,25 , Górna panewka jest oznakowana 'SPUTTER'.	
	79 445 600	[para] PL STD Ø 70.000 / 74.000 / 27.000 / 1.987 St/B/S, SPUTTER: u góry i u dołu, zastosowanie GAS	
	77 743 600	[komplet] HL STD Ø 77.000 / 82.000 / 26.000 / 2.480 St/B/G	
	77 805 600	[komplet] PL STD Ø 70.000 / 74.000 / 27.000 / 1.987 St/B/S; PL STD Ø 70.000 / 74.000 / 27.000 / 1.987 St/B/G, Górna panewka jest oznakowana 'SPUTTER'.	
	77 808 600	[komplet] NW-L STD Ø 54.940 / 59.000 / 25.000 / 2.000 St/B	
	77 927 690	[komplet] PL-B SEMI Ø 42.000 / 46.000 / 35.250 / St/B	
	20 0502 08343		
	81-25104	EX; 16.03/ x 10.02 x 55 G2	 92-25023 EX; 44.1 x 34.9 x 8.15; G2
	81-25105	IN; 16.03/ x 10.02 x 60 G2	 92-25024 IN; 46.043 x 37.3 x 7.8; G5; 30°
	20 1402 08260		
4		108	
E 0836		E 302, E 312	
		G	NA 6 6871 cm ³ 12V 56-85 kW 76-116 PS €13.0 125
	41 259 600	Ø cylindra: 108; KH: 62.8; MT: -14.9; MØ: 84.6; GL: 102; sworze tłokowy: 42x86; Liczba pierścieni: 3 RTK R 2.5 CR G3 M 2.5 DSF 4 CR	
	89 470 191	T - Sucha tuleja cylindra; semi; A=111.27 L=217	
	89 470 190	T - Sucha tuleja cylindra; semi; A=111.6 C=116 L=218 H=5.04	
	89 470 110	T - Sucha tuleja cylindra; skoczony; A=111.49 C=116 L=217 H=4.04	
	89 453 110	T - Sucha tuleja cylindra; skoczony; A=111.99 C=116 L=217 H=4.04, Nadwymiar zewnętrzny + 0,50 mm	
	79 234 600	[para] HL STD Ø 77.000 / 82.000 / 26.000 / 2.480 St/B/G 79 234 610 0,25 / 79 234 620 0,50	
	79 299 600	[para] AS STD Ø 84.850 / 102.450 // 2.900 St/A	
	79 333 600	[para] PL STD Ø 70.000 / 74.000 / 27.000 / 1.987 St/B/S; PL STD Ø 70.000 / 74.000 / 27.000 / 1.987 St/B/G 79 333 610 0,25 , Górna panewka jest oznakowana 'SPUTTER'.	
	79 445 600	[para] PL STD Ø 70.000 / 74.000 / 27.000 / 1.987 St/B/S, SPUTTER: u góry i u dołu, zastosowanie GAS	
	77 744 600	[komplet] HL STD Ø 77.000 / 82.000 / 26.000 / 2.480 St/B/G 77 744 610 0,25 / 77 744 620 0,50	
	77 807 600	[komplet] PL STD Ø 70.000 / 74.000 / 27.000 / 1.987 St/B/S; PL STD Ø 70.000 / 74.000 / 27.000 / 1.987 St/B/G 77 807 610 0,25 , Górna panewka jest oznakowana 'SPUTTER'.	
	77 809 600	[komplet] NW-L STD Ø 54.940 / 59.000 / 25.000 / 2.000 St/B	
	77 930 690	[komplet] PL-B SEMI Ø 42.000 / 46.000 / 35.250 / St/B	
	20 0502 08360	rednica kołnierza koła zamachowego: 110	
	20 0502 08362		
	81-25104	EX; 16.03/ x 10.02 x 55 G2	 92-25023 EX; 44.1 x 34.9 x 8.15; G2
	81-25105	IN; 16.03/ x 10.02 x 60 G2	 92-25022 IN; 51.1 x 41.6 x 7.45; G2
	20 1002 08361	Długo: 781, Euro 2/3 Przed montażem sprawdzi instrukcje producenta i upewnij się, że pompa wody jest prawidłowo przyporzadkowana do piasty.	
	20 1402 08260		

M

5  **108**
E 0836 **LE 202** G LA 6 6871 cm³ 12V 110 kW 150 PS € 11.0  125

	40 832 600	Ø cylindra: 108; KH: 63.5; VT1: -5; MT: -20.4; MØ: 70.1; GL: 102.5; sworze tłokowy: 42x86; Liczba piercieni: 3 RTK T15 3 CK G6 M 2.5 CR G3 D 4 CR
---	-------------------	---

	89 470 191	T - Sucha tuleja cylindra; semi; A=111.27 L=217
	89 470 190	T - Sucha tuleja cylindra; semi; A=111.6 C=116 L=218 H=5.04
	89 470 110	T - Sucha tuleja cylindra; skoczony; A=111.49 C=116 L=217 H=4.04
	89 453 110	T - Sucha tuleja cylindra; skoczony; A=111.99 C=116 L=217 H=4.04, Nadwymiar zewnętrzny + 0,50 mm
	79 234 600	[para] HL STD Ø 77.000 / 82.000 / 26.000 / 2.480 St/B/G 79 234 610 0,25 / 79 234 620 0,50
	79 299 600	[para] AS STD Ø 84.850 / 102.450 // 2.900 St/A
	79 333 600	[para] PL STD Ø 70.000 / 74.000 / 27.000 / 1.987 St/B/S; PL STD Ø 70.000 / 74.000 / 27.000 / 1.987 St/B/G 79 333 610 0,25 , Górna panewka jest oznakowana 'SPUTTER'.
	79 445 600	[para] PL STD Ø 70.000 / 74.000 / 27.000 / 1.987 St/B/S, SPUTTER: u góry i u dołu, zastosowanie GAS
	77 744 600	[komplet] HL STD Ø 77.000 / 82.000 / 26.000 / 2.480 St/B/G 77 744 610 0,25 / 77 744 620 0,50
	77 807 600	[komplet] PL STD Ø 70.000 / 74.000 / 27.000 / 1.987 St/B/S; PL STD Ø 70.000 / 74.000 / 27.000 / 1.987 St/B/G 77 807 610 0,25 , Górna panewka jest oznakowana 'SPUTTER'.
	77 809 600	[komplet] NW-L STD Ø 54.940 / 59.000 / 25.000 / 2.000 St/B
	77 930 690	[komplet] PL-B SEMI Ø 42.000 / 46.000 / 35.250 / St/B

	20 0502 08360	rednica kołnierza koła zamachowego: 110
	20 0502 08362	

	81-25104	EX; 16.03/ x 10.02 x 55 G2		92-25023	EX; 44.1 x 34.9 x 8.15; G2
	81-25105	IN; 16.03/ x 10.02 x 60 G2		92-25022	IN; 51.1 x 41.6 x 7.45; G2

M

	20 1002 08361	Długo: 781, Euro 2/3 Przed montażem sprawdzi instrukcje producenta i upewni się, że pompa wody jest prawidłowo przyporzadkowana do piasty.
---	----------------------	---

	20 1402 08260	
---	----------------------	--

	20 1902 08360	Długo: 144; Szeroko: 78; Wysoko: 60.3; Masa: 1.13 g
---	----------------------	---

6  **108**
E 0824 **E 302** G 4 4580 cm³ 2V  125







	89 470 190	T - Sucha tuleja cylindra; semi; A=111.6 C=116 L=218 H=5.04
	89 470 110	T - Sucha tuleja cylindra; skoczony; A=111.49 C=116 L=217 H=4.04
	89 453 110	T - Sucha tuleja cylindra; skoczony; A=111.99 C=116 L=217 H=4.04, Nadwymiar zewnętrzny + 0,50 mm





	79 234 600	[para] HL STD Ø 77.000 / 82.000 / 26.000 / 2.480 St/B/G 79 234 610 0,25 / 79 234 620 0,50
	79 235 600	[para] PASS-L STD Ø 77.000 / 82.000 / 33.850 / 2.480 St/B/G 79 235 610 0,25
	79 236 600	[para] PL STD Ø 65.000 / 69.000 / 31.000 / 1.987 St/B/G1 79 236 610 0,25 / 79 236 620 0,50
	77 586 600	[komplet] HL STD Ø 77.000 / 82.000 / 26.000 / 2.480 St/B/G; PASS-L STD Ø 77.000 / 82.000 / 33.850 / 2.480 St/B/G 77 586 610 0,25
	77 588 600	[komplet] PL STD Ø 65.000 / 69.000 / 31.000 / 1.987 St/B/G1 77 588 610 0,25
	77 810 600	[komplet] NW-L STD Ø 50.940 / 55.000 / 25.000 / 2.000 St/B
	77 885 690	[komplet] PL-B SEMI Ø 40.000 / 43.000 / 31.700 / St/B

	20 0602 08261	Długo: 187; rednica otworu lepego dnej główki korbwodu: 69; rednica małej główki korbwodu: 40; Szeroko stopy korbwodu: 39; Szeroko łba korbwodu: 32.5; korbwód równoległy; krakowany
---	----------------------	--













	81-25104	EX; 16.03/ x 10.02 x 55 G2		92-25023	EX; 44.1 x 34.9 x 8.15; G2
	81-25105	IN; 16.03/ x 10.02 x 60 G2		92-25022	IN; 51.1 x 41.6 x 7.45; G2



















	20 1402 08340	
---	----------------------	--

7		108	
E 0826		E 302	
		G	6 6596 cm ³ 2V
		120	
	89 470 190	T - Sucha tuleja cylindra; semi; A=111.6 C=116 L=218 H=5.04	
	89 470 110	T - Sucha tuleja cylindra; skoczony; A=111.49 C=116 L=217 H=4.04	
	89 453 110	T - Sucha tuleja cylindra; skoczony; A=111.99 C=116 L=217 H=4.04, Nadwymiar zewnętrzny + 0,50 mm	
	79 234 600	[para] HL STD Ø 77.000 / 82.000 / 26.000 / 2.480 St/B/G 79 234 610 0,25 / 79 234 620 0,50	
	79 235 600	[para] PASS-L STD Ø 77.000 / 82.000 / 33.850 / 2.480 St/B/G 79 235 610 0,25	
	79 236 600	[para] PL STD Ø 65.000 / 69.000 / 31.000 / 1.987 St/B/G1 79 236 610 0,25 / 79 236 620 0,50	
	77 587 600	[komplet] HL STD Ø 77.000 / 82.000 / 26.000 / 2.480 St/B/G; PASS-L STD Ø 77.000 / 82.000 / 33.850 / 2.480 St/B/G 77 587 610 0,25 / 77 587 620 0,50	
	77 589 600	[komplet] PL STD Ø 65.000 / 69.000 / 31.000 / 1.987 St/B/G1 77 589 610 0,25 / 77 589 620 0,50	
	77 811 600	[komplet] NW-L STD Ø 50.940 / 55.000 / 25.000 / 2.000 St/B	
	77 886 690	[komplet] PL-B SEMI Ø 40.000 / 43.000 / 31.700 / St/B	
	20 0602 08261	Długo: 187; rednica otworu lepego duej główki korbowodu: 69; rednica małej główki korbowodu: 40; Szeroko stopy korbowodu: 39; Szeroko łba korbowodu: 32.5; korbowód równoległy; krakowany	
	81-25104	EX; 16.03/ x 10.02 x 55 G2	 92-25023 EX; 44.1 x 34.9 x 8.15; G2
	81-25105	IN; 16.03/ x 10.02 x 60 G2	 92-25022 IN; 51.1 x 41.6 x 7.45; G2
	20 1402 20660	Przy zamawianiu zwróci uwag na nastpujce punkty: W przypadku stosowania pompy oleju BF ORIGINAL 20 1402 20660 zwraca uwag na wyposaenie standardowe poszczególnych komponentów oraz na numery OE. Jest to kompletny zestaw pomp oleju. Zastosowanie do pokrywy pompy oleju 51.05103-5036., Przy zamawianiu zwróci uwag na nastpujce punkty: W przypadku stosowania pompy oleju BF ORIGINAL 20 1402 20660 zwraca uwag na wyposaenie standardowe poszczególnych komponentów oraz na numery OE. Jest to kompletny zestaw pomp. Zastosowanie do pokrywy pompy oleju 51.05103-5036	

8		126	
E 2676		E 302	
		G NA 6 12419 cm ³ 24V 140-160 kW 190-218 PS	€ 12.0 166
	80 00728 1 0 000	Ø126; STD; Zestaw: 1; [T15 G6 CK 4] [M G3 CR 3] [DSF CR 4]	
	89 856 111	N - Mokra tuleja cylindra; skoczony; A=139.5 C=150 L=257.5 H=8.07	
	89 928 110	N - Mokra tuleja cylindra; skoczony; A=139.5 C=150 L=257.5 H=8.32	
	36 099 600	BU STD Ø 96.890 / 102.000 / 18.000 / 2.500 St/A, z rowkami	
	36 100 600	BU STD Ø 96.890 / 102.000 / 18.000 / 2.500 St/A, z otworem olejowym	
	78 586 600	[para] HL STD Ø 104.000 / 111.000 / 36.000 / 3.478 St/B/G1 78 586 605 0,10 / 78 586 610 0,25 / 78 586 620 0,50 / 78 586 630 0,75	
	79 261 600	[para] AS STD Ø 114.750 / 137.650 // 3.400 St/A 79 261 610 0,40 / 79 261 620 0,80	
	79 405 600	[para] PL STD Ø 90.000 / 95.000 / 36.200 / 2.479 St/B/S; PL STD Ø 90.000 / 95.000 / 36.200 / 2.479 St/B/G 79 405 610 0,25 / 79 405 620 0,50 , Górna panewka jest oznakowana 'SPUTTER'.	
	79 600 600	[para] PL STD Ø 90.000 / 95.000 / 36.200 / 2.479 St/B/G; PL STD Ø 90.000 / 95.000 / 36.200 / 2.479 St/B/S 79 600 610 0,25 / 79 600 620 0,50 , Górna panewka jest oznakowana 'SPUTTER'.	
	37 280 600	[komplet] PL STD Ø 90.000 / 95.000 / 36.200 / 2.479 St/B/G; PL STD Ø 90.000 / 95.000 / 36.200 / 2.479 St/B/S 37 280 610 0,25 / 37 280 620 0,50 , Górna panewka jest oznakowana 'SPUTTER'.	
	77 682 600	[komplet] HL STD Ø 104.000 / 111.000 / 36.000 / 3.478 St/B/G1 77 682 610 0,25 / 77 682 620 0,50	
	77 682 700	[komplet] HL STD Ø 104.000 / 111.500 / 36.000 / 3.728 St/B/G1 77 682 710 0,25 , Nadwymiar zewnętrzny + 0,50 mm	
	77 879 600	[komplet] PL STD Ø 90.000 / 95.000 / 36.200 / 2.479 St/B/G; PL STD Ø 90.000 / 95.000 / 36.200 / 2.479 St/B/S 77 879 610 0,25 / 77 879 620 0,50 , Górna panewka jest oznakowana 'SPUTTER'.	
	77 928 690	[komplet] PL-B SEMI Ø 52.000 / 56.000 / 45.500 / St/B	
	77 964 600	[komplet] NW-L STD Ø 39.950 / 44.000 / 26.000 / 2.010 St/A	
	20 0602 26761	Długo: 250.99; rednica otworu lepego duej główki korbowodu: 95; rednica małej główki korbowodu: 52.055; Szeroko stopy korbowodu: 43.3; Szeroko łba korbowodu: 43.3; krakowany	
	20 0602 26760	Długo: 251; rednica otworu lepego duej główki korbowodu: 95; rednica małej główki korbowodu: 52.05; Szeroko stopy korbowodu: 43.25; Szeroko łba korbowodu: 43.35; krakowany	
	20 0502 26760		





cont...



	81-25106	IN/EX; 15.05/ x 9 x 66.5 G2
	20 1402 26761	Przy zamawianiu zwróci uwagę na następujące punkty: W przypadku stosowania pompy oleju BF ORIGINAL 20 1402 26761 zwraca uwagę na wyposażenie standardowe poszczególnych komponentów oraz na numery OE. Jest to kompletny zestaw pomp. Zastosowanie do pokrywy pompy 51.05103-5038
9		126
	E 2676	LE 202, LE 212
		G LA 6 12419 cm ³ 24V 220-250 kW 299-340 PS £ 19.0  166
	80 00728 1 0 000	Ø126; STD; Zestaw: 1; [T15 G6 CK 4] [M G3 CR 3] [DSF CR 4]
	89 856 111	N - Mokra tuleja cylindra; skoczony; A=139.5 C=150 L=257.5 H=8.07
	89 928 110	N - Mokra tuleja cylindra; skoczony; A=139.5 C=150 L=257.5 H=8.32
	36 099 600	BU STD Ø 96.890 / 102.000 / 18.000 / 2.500 St/A, z rowkami
	36 100 600	BU STD Ø 96.890 / 102.000 / 18.000 / 2.500 St/A, z otworem olejowym
	78 586 600	[para] HL STD Ø 104.000 / 111.000 / 36.000 / 3.478 St/B/G1 78 586 605 0,10 / 78 586 610 0,25 / 78 586 620 0,50 / 78 586 630 0,75
	79 261 600	[para] AS STD Ø 114.750 / 137.650 // 3.400 St/A 79 261 610 0,40 / 79 261 620 0,80
	79 405 600	[para] PL STD Ø 90.000 / 95.000 / 36.200 / 2.479 St/B/S; PL STD Ø 90.000 / 95.000 / 36.200 / 2.479 St/B/G 79 405 610 0,25 / 79 405 620 0,50 , Górna panewka jest oznakowana 'SPUTTER'.
	79 600 600	[para] PL STD Ø 90.000 / 95.000 / 36.200 / 2.479 St/B/G; PL STD Ø 90.000 / 95.000 / 36.200 / 2.479 St/B/S 79 600 610 0,25 / 79 600 620 0,50 , Górna panewka jest oznakowana 'SPUTTER'.
	37 280 600	[komplet] PL STD Ø 90.000 / 95.000 / 36.200 / 2.479 St/B/G; PL STD Ø 90.000 / 95.000 / 36.200 / 2.479 St/B/S 37 280 610 0,25 / 37 280 620 0,50 , Górna panewka jest oznakowana 'SPUTTER'.
	77 682 600	[komplet] HL STD Ø 104.000 / 111.000 / 36.000 / 3.478 St/B/G1 77 682 610 0,25 / 77 682 620 0,50
	77 682 700	[komplet] HL STD Ø 104.000 / 111.500 / 36.000 / 3.728 St/B/G1 77 682 710 0,25 , Nadwymiar zewnętrzny + 0,50 mm
	77 879 600	[komplet] PL STD Ø 90.000 / 95.000 / 36.200 / 2.479 St/B/G; PL STD Ø 90.000 / 95.000 / 36.200 / 2.479 St/B/S 77 879 610 0,25 / 77 879 620 0,50 , Górna panewka jest oznakowana 'SPUTTER'.
	77 928 690	[komplet] PL-B SEMI Ø 52.000 / 56.000 / 45.500 / St/B
	77 964 600	[komplet] NW-L STD Ø 39.950 / 44.000 / 26.000 / 2.010 St/A
	20 0602 26761	Długo: 250.99; rednica otworu lepego duej główki korbowodu: 95; rednica małej główki korbowodu: 52.055; Szeroko stopy korbowodu: 43.3; Szeroko łba korbowodu: 43.3; krakowany
	20 0602 26760	Długo: 251; rednica otworu lepego duej główki korbowodu: 95; rednica małej główki korbowodu: 52.05; Szeroko stopy korbowodu: 43.25; Szeroko łba korbowodu: 43.35; krakowany
	20 0502 26760	
	81-25106	IN/EX; 15.05/ x 9 x 66.5 G2
	20 1402 20660	Przy zamawianiu zwróci uwagę na następujące punkty: W przypadku stosowania pompy oleju BF ORIGINAL 20 1402 20660 zwraca uwagę na wyposażenie standardowe poszczególnych komponentów oraz na numery OE. Jest to kompletny zestaw pomp oleju. Zastosowanie do pokrywy pompy oleju 51.05103-5036., Przy zamawianiu zwróci uwagę na następujące punkty: W przypadku stosowania pompy oleju BF ORIGINAL 20 1402 20660 zwraca uwagę na wyposażenie standardowe poszczególnych komponentów oraz na numery OE. Jest to kompletny zestaw pomp. Zastosowanie do pokrywy pompy oleju 51.05103-5036
	20 1402 26760	Przy zamawianiu zwróci uwagę na następujące punkty: W przypadku stosowania pompy oleju BF ORIGINAL 20 1402 26760 zwraca uwagę na wyposażenie standardowe poszczególnych komponentów oraz na numery OE. Jest to kompletny zestaw pomp. Zastosowanie do pokrywy pompy oleju 51.05103-5037
	20 1402 26761	Przy zamawianiu zwróci uwagę na następujące punkty: W przypadku stosowania pompy oleju BF ORIGINAL 20 1402 26761 zwraca uwagę na wyposażenie standardowe poszczególnych komponentów oraz na numery OE. Jest to kompletny zestaw pomp. Zastosowanie do pokrywy pompy oleju 51.05103-5038
	20 1902 20661	Długo: 250; Szeroko: 78; Wysoko: 81; Masa: 3.02 g

10		128	
E 2842		LE 202, LE 302	
		G LA 12 21927 cm ³ 24V 360-420 kW 489-571 PS ⌀12.0 142	
	20 1902 28420	Długo: 250; Szeroko: 78; Wysoko: 197; Masa: 6.75 g	
11		128	
E 2842		LE 312	
		G LA 12 21927 cm ³ 24V 360-420 kW 490-571 PS ⌀12.0 142	
	40 208 600	Ø cylindra: 128; KH: 80.7; MT: -28.2; MØ: 94; GL: 129.7; sworze tłokowy: 46x105; Liczba pierścieni: 3 RTK T15 3.5 CR G6 M 3 DSF 5 CR → 80 00155 1 0 ...	
			
	41 000 600	Ø cylindra: 128; KH: 80.7; MT: -26; MØ: 91.6; GL: 129.7; sworze tłokowy: 46x105; Liczba pierścieni: 3 RTK T15 4 CK G6 M 3 CR G3 DSF 4 CR → 80 01100 1 0 ...	
			
	42 043 600	Ø cylindra: 128; KH: 80.7; MT: -21.7; MØ: 90; GL: 129.7; sworze tłokowy: 46x105; Liczba pierścieni: 3 RTK T15 3.5 CR G6 M 3 DSF 5 CR → 80 00155 1 0 ...	
	80 00155 1 0 000	Ø128; STD; Zestaw: 1; [T15 G6 CR 3.5] [M 3] [DSF CR 5]	
	80 00717 1 0 000	Ø128; STD; Zestaw: 1; [T15 G6 CK 4] [M G3 3] [DSF CR 4]	
	80 01100 1 0 000	Ø128; STD; Zestaw: 1; [T15 G6 CK 4] [M G3 CR 3] [DSF CR 4]	
	41 000 960	tłoki: 41000600; tuleja cylindrowa: 89092120	
	42 043 960	tłoki: 42043600; tuleja cylindrowa: 89092120	
	89 092 120	N - Mokra tuleja cylindra; skoczony; A=144.5 C=153.8 L=253 H+F=10.05+1	
	89 093 120	N - Mokra tuleja cylindra; skoczony; A=145 C=154.3 L=253 H+F=10.05+1	
	78 693 600	[para] HL STD Ø 104.000 / 111.000 / 30.500 / 3.472 St/B/G1 78 693 610 0,25 / 78 693 620 0,50 / 78 693 630 0,75 / 78 693 640 1,00	
	78 694 604	[para] PASS-L STD Ø 104.000 / 111.000 / 37.810 / 3.474 St/B/G 78 694 614 0,25 / 78 694 624 0,50 / 78 694 634 0,75 / 78 694 644 1,00	
	78 709 600	[para] PL-L STD Ø 31.975 / 36.000 / 19.000 / 2.011 St/B/G, Do sprarek powietrza z tłokami Ø 90 mm.	
	78 897 600	[para] PL STD Ø 90.000 / 95.000 / 31.000 / 2.473 St/B/S; PL STD Ø 90.000 / 95.000 / 31.000 / 2.473 St/B/G1 78 897 605 0,10 / 78 897 610 0,25 / 78 897 620 0,50 / 78 897 630 0,75 / 78 897 640 1,00, Górna panewka jest oznakowana 'SPUTTER'. W silnikach na gaz i do łodzi montowa łożyska korbwodowe 'SPUTTER'!	
	79 443 600	[para] PL STD Ø 90.000 / 95.000 / 31.000 / 2.473 St/B/S, SPUTTER: u góry i u dołu, zastosowanie GAS	
	87 346 690	[komplet] PL-B SEMI Ø 46.000 / 50.600 / 38.700 / St/B	
	87 366 600	[komplet] NW-L STD Ø 69.940 / 76.000 / 35.000 / 3.000 St/B; NW-L STD Ø 69.940 / 75.000 / 28.000 / 2.500 St/A	
	87 397 604	[komplet] HL STD Ø 104.000 / 111.000 / 30.500 / 3.472 St/B/G1; PASS-L STD Ø 104.000 / 111.000 / 37.810 / 3.474 St/B/G 87 397 614 0,25 / 87 397 624 0,50	
	20 0602 G2801	Długo: 256; rednica otworu lepego duej główki korbwododu: 95; rednica małej główki korbwododu: 46; Szeroko stopy korbwododu: 33; Szeroko łba korbwododu: 39; korbwodód trapezowy; krakowany	
	20 0302 28420	bez tulei cylindra	
	20 0802 G2820	- V - G - S - - - -; element gotowy do montau, Uywaj do wiecy zapłonowej M14	
	20 0802 G2828	- V - G - S - - - -; element gotowy do montau	
	20 0802 G2840	- V - G - S - - - -; element gotowy do montau, Uywaj do wiecy zapłonowej M14	



cont...





M

	25311	EX; 51 x 12 x 142.5 x I/S - Cr - 30° - VS - 1 - III		KK-12H	stoeek zaworu; Liczba karbów: 1; rednica trzonka zaworu: 12
	25324	EX; 51 x 12 x 142.5 x RA/S - Cr - 30° - 1 - III		81-25103	EX; 18/ x 12 x 70 G2, Długo rowka olejowego jest różna w zależności od głowicy! 81-25103 ma krótki rowek olejowy. Dopiero po wymontowaniu przewodnicy zaworu można stwierdzić jej wersję. Nie można odróżnić wersji po numerach silnika.
	25310	IN; 58 x 12 x 142.5 x I/S - Cr - 30° - VS - 1 - III		81-25107	EX; 18.2/ x 12.02 x 56 G2
	92-25004	EX; 53.1 x 43 x 7.45; G2; 30°		81-25101	IN; 18/ x 12.02 x 59.5 G2
	92-25018	EX; 53.11 x 43 x 9.5; HWR		81-2536	IN/EX; 18/ x 12 x 64 G2, W przypadku stosowania gazu używać tylko w obszarze dolotu.
	92-25005	IN; 61.11 x 49 x 6.8; G2; 30°		81-2537	IN/EX; 18.2/ x 12 x 64 G2, W przypadku stosowania gazu używać tylko w obszarze dolotu.
	92-25019	IN; 61.11 x 49 x 8.8; HWR		81-2538	IN/EX; 18.4/ x 12 x 64 G2, W przypadku stosowania gazu używać tylko w obszarze dolotu.









	20 1403 44300	
	20 1403 44400	
	20 1902 28420	Długo: 250; Szeroko: 78; Wysoko: 197; Masa: 6.75 g

12		128	E 2842	LE 322	G LA 12 21927 cm ³ 24V 380-420 kW 517-571 PS €12.0 H 142
-----------	---	------------	---------------	---------------	---







	40 208 600	Ø cylindra: 128; KH: 80.7; MT: -28.2; MØ: 94; GL: 129.7; sworze tłokowy: 46x105; Liczba pierścieni: 3 RTK T15 3.5 CR G6 M 3 DSF 5 CR → 80 00155 1 0 ...
	41 000 600	Ø cylindra: 128; KH: 80.7; MT: -26; MØ: 91.6; GL: 129.7; sworze tłokowy: 46x105; Liczba pierścieni: 3 RTK T15 4 CK G6 M 3 CR G3 DSF 4 CR → 80 01100 1 0 ...
	42 043 600	Ø cylindra: 128; KH: 80.7; MT: -21.7; MØ: 90; GL: 129.7; sworze tłokowy: 46x105; Liczba pierścieni: 3 RTK T15 3.5 CR G6 M 3 DSF 5 CR → 80 00155 1 0 ...

	80 00155 1 0 000	Ø128; STD; Zestaw: 1; [T15 G6 CR 3.5] [M 3] [DSF CR 5]
	80 00717 1 0 000	Ø128; STD; Zestaw: 1; [T15 G6 CK 4] [M G3 3] [DSF CR 4]
	80 01100 1 0 000	Ø128; STD; Zestaw: 1; [T15 G6 CK 4] [M G3 CR 3] [DSF CR 4]
	41 000 960	tłoki: 41000600; tuleja cylindrowa: 89092120
	42 043 960	tłoki: 42043600; tuleja cylindrowa: 89092120
	89 092 120	N - Mokra tuleja cylindra; skoczony; A=144.5 C=153.8 L=253 H+F=10.05+1
	89 093 120	N - Mokra tuleja cylindra; skoczony; A=145 C=154.3 L=253 H+F=10.05+1
	78 693 600	[para] HL STD Ø 104.000 / 111.000 / 30.500 / 3.472 St/B/G1 78 693 610 0,25 / 78 693 620 0,50 / 78 693 630 0,75 / 78 693 640 1,00
	78 694 604	[para] PASS-L STD Ø 104.000 / 111.000 / 37.810 / 3.474 St/B/G 78 694 614 0,25 / 78 694 624 0,50 / 78 694 634 0,75 / 78 694 644 1,00
	78 709 600	[para] PL-L STD Ø 31.975 / 36.000 / 19.000 / 2.011 St/B/G, Do sprarek powietrza z tłokami Ø 90 mm.











cont...



78 897 600	[para] PL STD Ø 90.000 / 95.000 / 31.000 / 2.473 St/B/S; PL STD Ø 90.000 / 95.000 / 31.000 / 2.473 St/B/G1 78 897 605 0,10 / 78 897 610 0,25 / 78 897 620 0,50 / 78 897 630 0,75 / 78 897 640 1,00, Górna panewka jest oznakowana 'SPUTTER'. W silnikach na gaz i do łodzi montowa łożyska korbwodowe 'SPUTTER'!		
79 443 600	[para] PL STD Ø 90.000 / 95.000 / 31.000 / 2.473 St/B/S, SPUTTER: u góry i u dołu, zastosowanie GAS		
87 346 690	[komplet] PL-B SEMI Ø 46.000 / 50.600 / 38.700 / St/B		
87 366 600	[komplet] NW-L STD Ø 69.940 / 76.000 / 35.000 / 3.000 St/B; NW-L STD Ø 69.940 / 75.000 / 28.000 / 2.500 St/A		
87 397 604	[komplet] HL STD Ø 104.000 / 111.000 / 30.500 / 3.472 St/B/G1; PASS-L STD Ø 104.000 / 111.000 / 37.810 / 3.474 St/B/G 87 397 614 0,25 / 87 397 624 0,50		
 20 0602 G2801	Długo: 256; rednica otworu lepego duej główki korbwodu: 95; rednica małej główki korbwodu: 46; Szeroko stopy korbwodu: 33; Szeroko łba korbwodu: 39; korbwóó trapezowy; krakowany		
 20 0302 28420	bez tulei cylindra		
 20 0802 G2820	- V - G - S - - - - -; element gotowy do montau, Uywj do wiecy zapłonowej M14		
20 0802 G2828	- V - G - S - - - - -; element gotowy do montau		
20 0802 G2840	- V - G - S - - - - -; element gotowy do montau, Uywj do wiecy zapłonowej M14		
 25311	EX; 51 x 12 x 142.5 x I/S - Cr - 30° - VS - 1 - III	 KK-10H	stoek zaworu; Liczba karbów: 1; rednica trzonka zaworu: 10
25324	EX; 51 x 12 x 142.5 x RA/S - Cr - 30° - 1 - III	KK-12H	stoek zaworu; Liczba karbów: 1; rednica trzonka zaworu: 12
25310	IN; 58 x 12 x 142.5 x I/S - Cr - 30° - VS - 1 - III	 81-25103	EX; 18/ x 12 x 70 G2, Długo rowka olejowego jest róna w zalenoci od głowicy! 81-25103 ma krótki rowek olejowy. Dopiero po wymontowaniu przewodnicy zaworu mona stwierdzi jej wersj. Nie mona odróni wersji po numerach silnika.
 92-25004	EX; 53.1 x 43 x 7.45; G2; 30°	81-25107	EX; 18.2/ x 12.02 x 56 G2
92-25018	EX; 53.11 x 43 x 9.5; HWR	81-25101	IN; 18/ x 12.02 x 59.5 G2
92-25005	IN; 61.11 x 49 x 6.8; G2; 30°	81-2536	IN/EX; 18/ x 12 x 64 G2, W przypadku stosowania gazu uywa tylko w obszarze dolotu.
92-25019	IN; 61.11 x 49 x 8.8; HWR	81-2537	IN/EX; 18.2/ x 12 x 64 G2, W przypadku stosowania gazu uywa tylko w obszarze dolotu.
		81-2538	IN/EX; 18.4/ x 12 x 64 G2, W przypadku stosowania gazu uywa tylko w obszarze dolotu.
 20 1403 44300			
20 1403 44400			
 20 1902 28420	Długo: 250; Szeroko: 78; Wysoko: 197; Masa: 6.75 g		

M



13	 128
 E 2848	LE 322
G LA 8 14618 cm ³ 16V 265-295 kW 360-401 PS ξ 12.0  142	
 41 000 600	Ø cylindra: 128; KH: 80.7; MT: -26; MØ: 91.6; GL: 129.7; sworze tłokowy: 46x105; Liczba piercieni: 3 RTK T15 4 CK G6 M 3 CR G3 DSF 4 CR → 80 01100 1 0 ...
	
 42 043 600	Ø cylindra: 128; KH: 80.7; MT: -21.7; MØ: 90; GL: 129.7; sworze tłokowy: 46x105; Liczba piercieni: 3 RTK T15 3.5 CR G6 M 3 DSF 5 CR → 80 00155 1 0 ...
 80 00155 1 0 000	Ø128; STD; Zestaw: 1; [T15 G6 CR 3.5] [M 3] [DSF CR 5]
80 00300 1 0 000	Ø128; STD; Zestaw: 1; [T15 G6 CR 4] [M 3] [DSF CR 4]
80 01100 1 0 000	Ø128; STD; Zestaw: 1; [T15 G6 CK 4] [M G3 CR 3] [DSF CR 4]



cont...

	41 000 960	łtuki: 41000600; tuleja cylindrowa: 89092120
	42 043 960	łtuki: 42043600; tuleja cylindrowa: 89092120
	89 092 120	N - Mokra tuleja cylindra; skoczony; A=144.5 C=153.8 L=253 H+F=10.05+1
	89 093 120	N - Mokra tuleja cylindra; skoczony; A=145 C=154.3 L=253 H+F=10.05+1
	78 693 600	[para] HL STD Ø 104.000 / 111.000 / 30.500 / 3.472 St/B/G1 78 693 610 0,25 / 78 693 620 0,50 / 78 693 630 0,75 / 78 693 640 1,00
	78 694 604	[para] PASS-L STD Ø 104.000 / 111.000 / 37.810 / 3.474 St/B/G 78 694 614 0,25 / 78 694 624 0,50 / 78 694 634 0,75 / 78 694 644 1,00
	78 709 600	[para] PL-L STD Ø 31.975 / 36.000 / 19.000 / 2.011 St/B/G, Do sprarek powietrza z łtokami Ø 90 mm.
	78 897 600	[para] PL STD Ø 90.000 / 95.000 / 31.000 / 2.473 St/B/S; PL STD Ø 90.000 / 95.000 / 31.000 / 2.473 St/B/G1 78 897 605 0,10 / 78 897 610 0,25 / 78 897 620 0,50 / 78 897 630 0,75 / 78 897 640 1,00 , Górna panewka jest oznakowana 'SPUTTER', W silnikach na gaz i do łodzi montowa łoyška korbowodowe 'SPUTTER'!
	79 443 600	[para] PL STD Ø 90.000 / 95.000 / 31.000 / 2.473 St/B/S, SPUTTER: u góry i u dołu, zastosowanie GAS
	87 348 690	[komplet] PL-B SEMI Ø 46.000 / 50.600 / 38.700 / St/B
	87 385 694	[komplet] NW-L SEMI Ø 69.940 / 76.000 / 35.000 / St/B; NW-L SEMI Ø 69.940 / 75.000 / 28.000 / St/W
	87 401 604	[komplet] HL STD Ø 104.000 / 111.000 / 30.500 / 3.472 St/B/G1; PASS-L STD Ø 104.000 / 111.000 / 37.810 / 3.474 St/B/G 87 401 614 0,25 / 87 401 624 0,50 / 87 401 634 0,75 / 87 401 644 1,00
	20 0602 G2801	Długo: 256; rednica otworu lepego duej główki korbowodu: 95; rednica małej główki korbowodu: 46; Szeroko stopy korbowodu: 33; Szeroko łba korbowodu: 39; korbowód trapezowy; krakowany
	20 0302 25380	bez tulei cylindra
	20 0802 G2820	- V - G - S - - - - -; element gotowy do montau, Uywaj do wiecey zapłonowej M14
	20 0802 G2828	- V - G - S - - - - -; element gotowy do montau
	20 0802 G2840	- V - G - S - - - - -; element gotowy do montau, Uywaj do wiecey zapłonowej M14
	25311	EX; 51 x 12 x 142.5 x I/S - Cr - 30° - VS - 1 - III
	25324	EX; 51 x 12 x 142.5 x RA/S - Cr - 30° - 1 - III
	25310	IN; 58 x 12 x 142.5 x I/S - Cr - 30° - VS - 1 - III
	92-25004	EX; 53.1 x 43 x 7.45; G2; 30°
	92-25018	EX; 53.11 x 43 x 9.5; HWR
	92-25005	IN; 61.11 x 49 x 6.8; G2; 30°
	92-25019	IN; 61.11 x 49 x 8.8; HWR
	20 1403 44400	
	20 1902 28420	Długo: 250; Szeroko: 78; Wysoko: 197; Masa: 6.75 g



















	KK-12H	stoeł zaworu; Liczba karbów: 1; rednica trzonka zaworu: 12
	81-25103	EX; 18/ x 12 x 70 G2, Długo rowka olejowego jest róna w zalenoci od głowicy! 81-25103 ma krótki rowek olejowy. Dopiero po wymontowaniu przewodnicy zaworu mona stwierdzi jej wersj. Nie mona odróni wersji po numerach silnika.
	81-25107	EX; 18.2/ x 12.02 x 56 G2
	81-25101	IN; 18/ x 12.02 x 59.5 G2
	81-2536	IN/EX; 18/ x 12 x 64 G2, W przypadku stosowania gazu uywa tylko w obszarze dolotu.
	81-2537	IN/EX; 18.2/ x 12 x 64 G2, W przypadku stosowania gazu uywa tylko w obszarze dolotu.
	81-2538	IN/EX; 18.4/ x 12 x 64 G2, W przypadku stosowania gazu uywa tylko w obszarze dolotu.

M











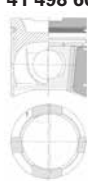

14		128
	E 2876 KAT	E 302
	E 2876	E 312
	G	6 12816 cm ³ 2V 130-140 kW 177-190 PS 166
	G LA	6 12816 cm ³ 12V 150-170 kW 204-231 PS 12.0 166

	41 260 600	Ø cylindra: 128; KH: 78.65; MT: -26.6; MØ: 93; GL: 133.65; sworze łtokowy: 50x107; Liczba piercieni: 3
		RTK
	T15	4 CK G6
	M	3 CR G3
	DSF	4 CR
		→ 80 01100 1 0 ...

































cont...

	80 00155 1 0 000	Ø128; STD; Zestaw: 1; [T15 G6 CR 3.5] [M 3] [DSF CR 5]	
	80 00300 1 0 000	Ø128; STD; Zestaw: 1; [T15 G6 CR 4] [M 3] [DSF CR 4]	
	80 01100 1 0 000	Ø128; STD; Zestaw: 1; [T15 G6 CK 4] [M G3 CR 3] [DSF CR 4]	
	41 260 960	tłoki: 41260600; tuleja cylindrowa: 89186120	
	89 186 120	N - Mokra tuleja cylindra; skoczony; A=144.5 C=153.8 L=270 H+F=10.07+1	
	89 914 120	N - Mokra tuleja cylindra; skoczony; A=144.5 C=153.8 L=270 H+F=10.07+1, płaszcz wodny powlek. plazmowo	
	89 518 120	N - Mokra tuleja cylindra; skoczony; A=144.5 C=153.8 L=270 H+F=10.27+1	
	89 324 120	N - Mokra tuleja cylindra; skoczony; A=144.5 C=153.8 L=270 H+F=10.57+1	
	89 892 120	N - Mokra tuleja cylindra; skoczony; A=145.5 C=154.3 L=270 H+F=10.07+1	
	78 586 600	[para] HL STD Ø 104.000 / 111.000 / 36.000 / 3.478 St/B/G1 78 586 605 0,10 / 78 586 610 0,25 / 78 586 620 0,50 / 78 586 630 0,75	
	79 237 600	[para] PL STD Ø 90.000 / 95.000 / 36.200 / 2.478 St/B/G1; PL STD Ø 90.000 / 95.000 / 36.200 / 2.479 St/B/S 79 237 610 0,25 / 79 237 620 0,50 / 79 237 630 0,75 , Górna panewka jest oznakowana 'SPUTTER'.	
	79 261 600	[para] AS STD Ø 114.750 / 137.650 // / 3.400 St/A 79 261 610 0,40 / 79 261 620 0,80	
	79 444 600	[para] PL STD Ø 90.000 / 95.000 / 36.200 / 2.479 St/B/S, SPUTTER: u góry i u dołu, zastosowanie GAS	
	77 682 600	[komplet] HL STD Ø 104.000 / 111.000 / 36.000 / 3.478 St/B/G1 77 682 610 0,25 / 77 682 620 0,50	
	77 682 700	[komplet] HL STD Ø 104.000 / 111.500 / 36.000 / 3.728 St/B/G1 77 682 710 0,25 , Nadwymiar zewnętrzny + 0,50 mm	
	77 812 690	[komplet] PL-B SEMI Ø 50.000 / 54.000 / 38.700 / St/B	
	87 501 600	[komplet] NW-L STD Ø 69.940 / 76.000 / 39.000 / 3.000 St/B; NW-L STD Ø 69.940 / 75.000 / 36.000 / 2.500 St/A; NW-L STD Ø 69.940 / 75.000 / 28.000 / 2.500 St/A	
	20 0602 G2876	Długo: 256; rednica otworu lepego duej główki korbowodu: 95; rednica malej główki korbowodu: 50.06; Szeroko stopy korbowodu: 45.85; Szeroko łba korbowodu: 39; korbowód trapezowy; krakowany	
	20 0502 28760	rednica kołnierza koła zamachowego: 113	
	20 0302 28661	bez tulei cylindra	
	20 0802 G2820	- V - G - S - - - - -; element gotowy do montau, Uywaj do wiecy zapłonowej M14	
	20 0802 G2828	- V - G - S - - - - -; element gotowy do montau	
	20 0802 G2840	- V - G - S - - - - -; element gotowy do montau, Uywaj do wiecy zapłonowej M14	
	25311	EX; 51 x 12 x 142.5 x I/S - Cr - 30° - VS - 1 - III	 KK-12H stoek zaworu; Liczba karbów: 1; rednica trzonka zaworu: 12
	25324	EX; 51 x 12 x 142.5 x RA/S - Cr - 30° - 1 - III	 81-25113 EX; 18/ x 12.01 x 70 G2
	25310	IN; 58 x 12 x 142.5 x I/S - Cr - 30° - VS - 1 - III	 81-25102 EX; 18/ x 12.02 x 56 G2
	92-25004	EX; 53.1 x 43 x 7.45; G2; 30°	81-25107 EX; 18.2/ x 12.02 x 56 G2
	92-25018	EX; 53.11 x 43 x 9.5; HWR	81-25101 IN; 18/ x 12.02 x 59.5 G2
	92-25005	IN; 61.11 x 49 x 6.8; G2; 30°	81-2536 IN/EX; 18/ x 12 x 64 G2, W przypadku stosowania gazu uywa tylko w obszarze dolotu.
	92-25019	IN; 61.11 x 49 x 8.8; HWR	81-2537 IN/EX; 18.2/ x 12 x 64 G2, W przypadku stosowania gazu uywa tylko w obszarze dolotu.
			81-2538 IN/EX; 18.4/ x 12 x 64 G2, W przypadku stosowania gazu uywa tylko w obszarze dolotu.
	20 1002 G2866		
	20 1402 28760		
	20 1402 28761		
	20 1902 28420	Długo: 250; Szeroko: 78; Wysoko: 197; Masa: 6.75 g, E 2876 E 302 : 01.2000→	
15	 128	LE 202	
	E 2876		
			G LA 6 12816 cm ³ 12V 220 kW 299 PS €12.0 166

M





	41 498 600	Ø cylindra: 128; KH: 78.65; VT1: -5; MT: -24.8; MØ: 102; GL: 133.65; sworze tłokowy: 50x107; Liczba pierścieni: 3 RTK T15 4 CR G6 M 3 DSF 4 CR → 80 00300 1 0 ...	
	80 00155 1 0 000 80 00300 1 0 000 80 00300 1 1 000 80 00300 1 2 000	Ø128; STD; Zestaw: 1; [T15 G6 CR 3.5] [M 3] [DSF CR 5] Ø128; STD; Zestaw: 1; [T15 G6 CR 4] [M 3] [DSF CR 4] Ø128; STD; Zestaw: 1; [T15 G6 CK 4] [M G3 3] [DSF CR 4] Ø128; STD; Zestaw: 1; [T15 G6 CR 4] [NM 3] [DSF CR 4]	
	41 498 960	tłoki: 41498600; tuleja cylindrowa: 89186120	
	89 186 120 89 914 120 89 518 120 89 324 120 89 892 120	N - Mokra tuleja cylindra; skoczony; A=144.5 C=153.8 L=270 H+F=10.07+1 N - Mokra tuleja cylindra; skoczony; A=144.5 C=153.8 L=270 H+F=10.07+1, płaszcz wodny powlek. plazmowo N - Mokra tuleja cylindra; skoczony; A=144.5 C=153.8 L=270 H+F=10.27+1 N - Mokra tuleja cylindra; skoczony; A=144.5 C=153.8 L=270 H+F=10.57+1 N - Mokra tuleja cylindra; skoczony; A=145.5 C=154.3 L=270 H+F=10.07+1	
	78 586 600 79 237 600 79 261 600 79 444 600 77 682 600 77 682 700 77 812 690 87 501 600	[para] HL STD Ø 104.000 / 111.000 / 36.000 / 3.478 St/B/G1 78 586 605 0,10 / 78 586 610 0,25 / 78 586 620 0,50 / 78 586 630 0,75 [para] PL STD Ø 90.000 / 95.000 / 36.200 / 2.478 St/B/G1; PL STD Ø 90.000 / 95.000 / 36.200 / 2.479 St/B/S 79 237 610 0,25 / 79 237 620 0,50 / 79 237 630 0,75 , Górna panewka jest oznakowana 'SPUTTER'. [para] AS STD Ø 114.750 / 137.650 // 3.400 St/A 79 261 610 0,40 / 79 261 620 0,80 [para] PL STD Ø 90.000 / 95.000 / 36.200 / 2.479 St/B/S, SPUTTER: u góry i u dołu, zastosowanie GAS [komplet] HL STD Ø 104.000 / 111.000 / 36.000 / 3.478 St/B/G1 77 682 610 0,25 / 77 682 620 0,50 [komplet] HL STD Ø 104.000 / 111.500 / 36.000 / 3.728 St/B/G1 77 682 710 0,25 , Nadwymiar zewnętrzny + 0,50 mm [komplet] PL-B SEMI Ø 50.000 / 54.000 / 38.700 / St/B [komplet] NW-L STD Ø 69.940 / 76.000 / 39.000 / 3.000 St/B; NW-L STD Ø 69.940 / 75.000 / 36.000 / 2.500 St/A; NW-L STD Ø 69.940 / 75.000 / 28.000 / 2.500 St/A	
	20 0602 G2876	Długo: 256; rednica otworu lepego dwej główki korbowodu: 95; rednica malej główki korbowodu: 50.06; Szeroko stopy korbowodu: 45.85; Szeroko łba korbowodu: 39; korbowód trapezowy; krakowany	
	20 0502 28760	rednica kołnierza koła zamachowego: 113	
	20 0302 28661	bez tulei cylindra	
	20 0802 G2820 20 0802 G2828 20 0802 G2840	- V - G - S - - - - ; element gotowy do montau, Uywaj do wiecey zapłonowej M14 - V - G - S - - - - ; element gotowy do montau - V - G - S - - - - ; element gotowy do montau, Uywaj do wiecey zapłonowej M14	
	25311 25324 25310 92-25004 92-25018 92-25005 92-25019	EX; 51 x 12 x 142.5 x I/S - Cr - 30° - VS - 1 - III EX; 51 x 12 x 142.5 x RA/S - Cr - 30° - 1 - III IN; 58 x 12 x 142.5 x I/S - Cr - 30° - VS - 1 - III EX; 53.1 x 43 x 7.45; G2; 30° EX; 53.11 x 43 x 9.5; HWR IN; 61.11 x 49 x 6.8; G2; 30° IN; 61.11 x 49 x 8.8; HWR	 KK-12H stoek zaworu; Liczba karbów: 1; rednica trzonka zaworu: 12  81-25103 EX; 18/ x 12 x 70 G2, Długo rowka olejowego jest różna w zalenoci od główicy! 81-25103 ma krótki rowek olejowy. Dopiero po wymontowaniu przewodnicy zaworu mona stwierdzi jej wersj. Nie mona odróni wersji po numerach silnika. 81-25113 EX; 18/ x 12.01 x 70 G2 81-25102 EX; 18/ x 12.02 x 56 G2 81-25107 EX; 18.2/ x 12.02 x 56 G2 81-25101 IN; 18/ x 12.02 x 59.5 G2 81-2536 IN/EX; 18/ x 12 x 64 G2, W przypadku stosowania gazu uywa tylko w obszarze dolotu. 81-2537 IN/EX; 18.2/ x 12 x 64 G2, W przypadku stosowania gazu uywa tylko w obszarze dolotu.



cont...

		81-2538	IN/EX; 18.4/ x 12 x 64 G2, W przypadku stosowania gazu uywa tylko w obszarze dolotu.
	20 1002 G2866		
	20 1402 28760		
	20 1402 28761		
	20 1902 28420	Długo: 250; Szeroko: 78; Wysoko: 197; Masa: 6.75 g	
16		128	
	E 2876	LE 302	
		G LA 6	12816 cm ³ 12V 200-210 kW 272-286 PS ξ11.0 166
	40 207 600	Ø cylindra: 128; KH: 78.65; MT: -25.3; MØ: 105.8; GL: 133.65; sworze tłokowy: 50x107; Liczba piercieni: 3 RTK T15 3.5 CR G6 M 3 DSF 5 CR → 80 00155 1 0 ...	
	80 00155 1 0 000	Ø128; STD; Zestaw: 1; [T15 G6 CR 3.5] [M 3] [DSF CR 5]	
	80 00300 1 0 000	Ø128; STD; Zestaw: 1; [T15 G6 CR 4] [M 3] [DSF CR 4]	
	40 207 960	tłoki: 40207600; tuleja cylindrowa: 89186120	
	40 207 961	tłoki: 40207600; tuleja cylindrowa: 89324120	
	40 207 963	tłoki: 40207600; tuleja cylindrowa: 89518120	
	40 207 964	tłoki: 40207600; tuleja cylindrowa: 89534120	
	89 186 120	N - Mokra tuleja cylindra; skoczony; A=144.5 C=153.8 L=270 H+F=10.07+1	
	89 914 120	N - Mokra tuleja cylindra; skoczony; A=144.5 C=153.8 L=270 H+F=10.07+1, płaszcz wodny powlek. plazmowo	
	89 518 120	N - Mokra tuleja cylindra; skoczony; A=144.5 C=153.8 L=270 H+F=10.27+1	
	89 324 120	N - Mokra tuleja cylindra; skoczony; A=144.5 C=153.8 L=270 H+F=10.57+1	
	89 892 120	N - Mokra tuleja cylindra; skoczony; A=145.5 C=154.3 L=270 H+F=10.07+1	
	78 586 600	[para] HL STD Ø 104.000 / 111.000 / 36.000 / 3.478 St/B/G1 78 586 605 0,10 / 78 586 610 0,25 / 78 586 620 0,50 / 78 586 630 0,75	
	79 237 600	[para] PL STD Ø 90.000 / 95.000 / 36.200 / 2.478 St/B/G1; PL STD Ø 90.000 / 95.000 / 36.200 / 2.479 St/B/S 79 237 610 0,25 / 79 237 620 0,50 / 79 237 630 0,75 , Górna panewka jest oznakowana 'SPUTTER'.	
	79 261 600	[para] AS STD Ø 114.750 / 137.650 // 3.400 St/A 79 261 610 0,40 / 79 261 620 0,80	
	79 444 600	[para] PL STD Ø 90.000 / 95.000 / 36.200 / 2.479 St/B/S, SPUTTER: u góry i u dołu, zastosowanie GAS	
	77 682 600	[komplet] HL STD Ø 104.000 / 111.000 / 36.000 / 3.478 St/B/G1 77 682 610 0,25 / 77 682 620 0,50	
	77 682 700	[komplet] HL STD Ø 104.000 / 111.500 / 36.000 / 3.728 St/B/G1 77 682 710 0,25 , Nadwymiar zewnętrzny + 0,50 mm	
	77 812 690	[komplet] PL-B SEMI Ø 50.000 / 54.000 / 38.700 / St/B	
	87 501 600	[komplet] NW-L STD Ø 69.940 / 76.000 / 39.000 / 3.000 St/B; NW-L STD Ø 69.940 / 75.000 / 36.000 / 2.500 St/A; NW-L STD Ø 69.940 / 75.000 / 28.000 / 2.500 St/A	
	20 0602 G2876	Długo: 256; rednica otworu lepego duej główki korbowodu: 95; rednica malej główki korbowodu: 50.06; Szeroko stopy korbowodu: 45.85; Szeroko łba korbowodu: 39; korbowód trapezowy; krakowany	
	20 0502 28760	rednica kołnierza koła zamachowego: 113	
	20 0302 28661	bez tulei cylindra	
	20 0802 G2820	- V - G - S - - - - -; element gotowy do montau, Uywj do wiecy zapłonowej M14	
	20 0802 G2828	- V - G - S - - - - -; element gotowy do montau	
	20 0802 G2840	- V - G - S - - - - -; element gotowy do montau, Uywj do wiecy zapłonowej M14	

cont...







M

	25311	EX; 51 x 12 x 142.5 x I/S - Cr - 30° - VS - 1 - III		KK-12H	stoeł zaworu; Liczba korbów: 1; rednica trzonka zaworu: 12
	25324	EX; 51 x 12 x 142.5 x RA/S - Cr - 30° - 1 - III		81-25103	EX; 18/ x 12 x 70 G2, Długo rowka olejowego jest różna w zależności od głowicy! 81-25103 ma krótki rowek olejowy. Dopiero po wymontowaniu przewodnicy zaworu można stwierdzić jej wersję. Nie można odróżnić wersji po numerach silnika.
	25310	IN; 58 x 12 x 142.5 x I/S - Cr - 30° - VS - 1 - III		81-25113	EX; 18/ x 12.01 x 70 G2
	92-25004	EX; 53.1 x 43 x 7.45; G2; 30°		81-25107	EX; 18.2/ x 12.02 x 56 G2
	92-25018	EX; 53.11 x 43 x 9.5; HWR		81-25101	IN; 18/ x 12.02 x 59.5 G2
	92-25005	IN; 61.11 x 49 x 6.8; G2; 30°		81-2536	IN/EX; 18/ x 12 x 64 G2, W przypadku stosowania gazu uwywa tylko w obszarze dolotu.
	92-25019	IN; 61.11 x 49 x 8.8; HWR		81-2537	IN/EX; 18.2/ x 12 x 64 G2, W przypadku stosowania gazu uwywa tylko w obszarze dolotu.
				81-2538	IN/EX; 18.4/ x 12 x 64 G2, W przypadku stosowania gazu uwywa tylko w obszarze dolotu.



















	20 1002 G2866	
	20 1402 28760 20 1402 28761	
	20 1902 28420	Długo: 250; Szeroko: 78; Wysoko: 197; Masa: 6.75 g

17		128	E 2876 Euro 5	LUH 01	G	LA	6	12816 cm ³	12V	228 kW	310 PS	€ 12.0	166
-----------	---	------------	----------------------	---------------	---	----	---	-----------------------	-----	--------	--------	--------	-----





M









	80 01269 1 0 000	Ø128
	89 186 120	N - Mokra tuleja cylindra; skoczony; A=144.5 C=153.8 L=270 H+F=10.07+1
	89 914 120	N - Mokra tuleja cylindra; skoczony; A=144.5 C=153.8 L=270 H+F=10.07+1, płaszcz wodny powłok. plazmowo
	89 518 120	N - Mokra tuleja cylindra; skoczony; A=144.5 C=153.8 L=270 H+F=10.27+1
	89 324 120	N - Mokra tuleja cylindra; skoczony; A=144.5 C=153.8 L=270 H+F=10.57+1
	89 892 120	N - Mokra tuleja cylindra; skoczony; A=145.5 C=154.3 L=270 H+F=10.07+1
	78 586 600	[para] HL STD Ø 104.000 / 111.000 / 36.000 / 3.478 St/B/G1 78 586 605 0,10 / 78 586 610 0,25 / 78 586 620 0,50 / 78 586 630 0,75
	79 237 600	[para] PL STD Ø 90.000 / 95.000 / 36.200 / 2.478 St/B/G1; PL STD Ø 90.000 / 95.000 / 36.200 / 2.479 St/B/S 79 237 610 0,25 / 79 237 620 0,50 / 79 237 630 0,75 , Górna panewka jest oznakowana 'SPUTTER'.
	79 261 600	[para] AS STD Ø 114.750 / 137.650 // 3.400 St/A 79 261 610 0,40 / 79 261 620 0,80
	79 444 600	[para] PL STD Ø 90.000 / 95.000 / 36.200 / 2.479 St/B/S, SPUTTER: u góry i u dołu, zastosowanie GAS
	77 682 600	[komplet] HL STD Ø 104.000 / 111.000 / 36.000 / 3.478 St/B/G1 77 682 610 0,25 / 77 682 620 0,50
	77 682 700	[komplet] HL STD Ø 104.000 / 111.500 / 36.000 / 3.728 St/B/G1 77 682 710 0,25 , Nadwymiar zewnętrzny + 0,50 mm
	77 812 690	[komplet] PL-B SEMI Ø 50.000 / 54.000 / 38.700 / St/B
	87 501 600	[komplet] NW-L STD Ø 69.940 / 76.000 / 39.000 / 3.000 St/B; NW-L STD Ø 69.940 / 75.000 / 36.000 / 2.500 St/A; NW-L STD Ø 69.940 / 75.000 / 28.000 / 2.500 St/A
	20 0602 G2876	Długo: 256; rednica otworu lepego duej główki korbowodu: 95; rednica małej główki korbowodu: 50.06; Szeroko stopy korbowodu: 45.85; Szeroko łba korbowodu: 39; korbowód trapezowy; krakowany
	20 0502 28760	rednica kołnierza koła zamachowego: 113
	20 0302 28661	bez tulei cylindra

















cont...

	25311	EX; 51 x 12 x 142.5 x I/S - Cr - 30° - VS - 1 - III		KK-12H	stoek zaworu; Liczba karbów: 1; rednica trzonka zaworu: 12			
	25324	EX; 51 x 12 x 142.5 x RA/S - Cr - 30° - 1 - III		81-25103	EX; 18/ x 12 x 70 G2, Długo rowka olejowego jest różna w zalenoci od głowicy! 81-25103 ma krótki rowek olejowy. Dopiero po wymontowaniu przewodnicy zaworu mona stwierdzi jej wersj. Nie mona odróni wersji po numerach silnika.			
	25310	IN; 58 x 12 x 142.5 x I/S - Cr - 30° - VS - 1 - III		81-25113	EX; 18/ x 12.01 x 70 G2			
	92-25004	EX; 53.1 x 43 x 7.45; G2; 30°		81-25102	EX; 18/ x 12.02 x 56 G2			
	92-25018	EX; 53.11 x 43 x 9.5; HWR		81-25107	EX; 18.2/ x 12.02 x 56 G2			
	92-25005	IN; 61.11 x 49 x 6.8; G2; 30°		81-25101	IN; 18/ x 12.02 x 59.5 G2			
	92-25019	IN; 61.11 x 49 x 8.8; HWR		81-2536	IN/EX; 18/ x 12 x 64 G2, W przypadku stosowania gazu uywa tylko w obszarze dolotu.			
				81-2537	IN/EX; 18.2/ x 12 x 64 G2, W przypadku stosowania gazu uywa tylko w obszarze dolotu.			
				81-2538	IN/EX; 18.4/ x 12 x 64 G2, W przypadku stosowania gazu uywa tylko w obszarze dolotu.			
	20 1002 G2866							
	20 1602 28661	mech.; rednica wirnika pompy: 135, do retardera		20 1402 28760				
	20 1902 25000	Długo: 250; Szeroko: 78; Wysoko: 107; Masa: 2.85 g						
	20 1902 28760	Długo: 250; Szeroko: 78; Wysoko: 111; Masa: 3 g						
	20 0502 25001	Koło łacuchowe, 49 zębów						
	20 1002 25020	wspornik dwigienki zaworowej, tylko 2-zaworowy						
18		128				M		
	E 2876 Euro 5	LUH 02						
		05.2007 →	G LA 6	12816 cm ³	12V 228 kW	310 PS	€ 12.0	166
	HOCL, LION´S CITY, LION´S CLASSIC, NG, NL							
	80 01269 1 0 000	Ø128						
	89 186 120	N - Mokra tuleja cylindra; skoczony; A=144.5 C=153.8 L=270 H+F=10.07+1						
	89 914 120	N - Mokra tuleja cylindra; skoczony; A=144.5 C=153.8 L=270 H+F=10.07+1, płaszcz wodny powlek. plazmowo						
	89 518 120	N - Mokra tuleja cylindra; skoczony; A=144.5 C=153.8 L=270 H+F=10.27+1						
	89 324 120	N - Mokra tuleja cylindra; skoczony; A=144.5 C=153.8 L=270 H+F=10.57+1						
	89 892 120	N - Mokra tuleja cylindra; skoczony; A=145.5 C=154.3 L=270 H+F=10.07+1						
	78 586 600	[para] HL STD Ø 104.000 / 111.000 / 36.000 / 3.478 St/B/G1 78 586 605 0,10 / 78 586 610 0,25 / 78 586 620 0,50 / 78 586 630 0,75						
	79 237 600	[para] PL STD Ø 90.000 / 95.000 / 36.200 / 2.478 St/B/G1; PL STD Ø 90.000 / 95.000 / 36.200 / 2.479 St/B/S 79 237 610 0,25 / 79 237 620 0,50 / 79 237 630 0,75 , Górna panewka jest oznakowana 'SPUTTER'.						
	79 261 600	[para] AS STD Ø 114.750 / 137.650 // / 3.400 St/A 79 261 610 0,40 / 79 261 620 0,80						
	79 444 600	[para] PL STD Ø 90.000 / 95.000 / 36.200 / 2.479 St/B/S, SPUTTER: u góry i u dołu, zastosowanie GAS						
	77 682 600	[komplet] HL STD Ø 104.000 / 111.000 / 36.000 / 3.478 St/B/G1 77 682 610 0,25 / 77 682 620 0,50						
	77 682 700	[komplet] HL STD Ø 104.000 / 111.500 / 36.000 / 3.728 St/B/G1 77 682 710 0,25 , Nadwymiar zewnętrzny + 0,50 mm						
	77 812 690	[komplet] PL-B SEMI Ø 50.000 / 54.000 / 38.700 / St/B						
	87 501 600	[komplet] NW-L STD Ø 69.940 / 76.000 / 39.000 / 3.000 St/B; NW-L STD Ø 69.940 / 75.000 / 36.000 / 2.500 St/A; NW-L STD Ø 69.940 / 75.000 / 28.000 / 2.500 St/A						
	20 0602 G2876	Długo: 256; rednica otworu lepego duej głowki korbowodu: 95; rednica malej głowki korbowodu: 50.06; Szeroko stopy korbowodu: 45.85; Szeroko łba korbowodu: 39; korbowód trapezowy; krakowany						
	20 0502 28760	rednica kołnierza koła zamachowego: 113						
	20 0302 28661	bez tulei cylindra						

















cont...

	25311	EX; 51 x 12 x 142.5 x I/S - Cr - 30° - VS - 1 - III		KK-12H	stoek zaworu; Liczba karbów: 1; rednica trzonka zaworu: 12
	25324	EX; 51 x 12 x 142.5 x RA/S - Cr - 30° - 1 - III		81-25103	EX; 18/ x 12 x 70 G2, Długo rowka olejowego jest różna w zalenoci od głowicy! 81-25103 ma krótki rowek olejowy. Dopiero po wymontowaniu przewodnicy zaworu mona stwierdzi jej wersj. Nie mona odróni wersji po numerach silnika.
	25310	IN; 58 x 12 x 142.5 x I/S - Cr - 30° - VS - 1 - III		81-25113	EX; 18/ x 12.01 x 70 G2
	92-25004	EX; 53.1 x 43 x 7.45; G2; 30°		81-25102	EX; 18/ x 12.02 x 56 G2
	92-25018	EX; 53.11 x 43 x 9.5; HWR		81-25107	EX; 18.2/ x 12.02 x 56 G2
	92-25005	IN; 61.11 x 49 x 6.8; G2; 30°		81-25101	IN; 18/ x 12.02 x 59.5 G2
	92-25019	IN; 61.11 x 49 x 8.8; HWR		81-2536	IN/EX; 18/ x 12 x 64 G2, W przypadku stosowania gazu uywa tylko w obszarze dolotu.
				81-2537	IN/EX; 18.2/ x 12 x 64 G2, W przypadku stosowania gazu uywa tylko w obszarze dolotu.
				81-2538	IN/EX; 18.4/ x 12 x 64 G2, W przypadku stosowania gazu uywa tylko w obszarze dolotu.

















	20 1002 G2866				
	20 1602 28661	mech.; rednica wirnika pompy: 135, do retardera		20 1402 28760	
	20 1902 25000	Długo: 250; Szeroko: 78; Wysoko: 107; Masa: 2.85 g			
	20 1902 28760	Długo: 250; Szeroko: 78; Wysoko: 111; Masa: 3 g			
	7.01268.03.0	zawór EGR; pneumat., Zawór zwrotny			
	7.00380.11.0	zawór regulacyjny cinienia doładowania; elektryczno-pneumatyczny			
	7.00380.04.0	zawór regulacyjny cinienia doładowania; elektryczny			
	20 0502 25001	Koło tacuchowe, 49 zbów			
	20 1002 25020	wspornik dwigienki zaworowej, tylko 2-zaworowy			

19		128									
	E 2876	TE 302									
			G	A	6	12816 cm ³	12V	130 kW	177 PS	£ 12.0	166
	41 260 600	Ø cylindra: 128; KH: 78.65; MT: -26.6; MØ: 93; GL: 133.65; sworze tłokowy: 50x107; Liczba piercieni: 3									
		RTK									
		T15 4 CK G6									
		M 3 CR G3									
		DSF 4 CR									
		→ 80 01100 1 0 ...									
	80 00155 1 0 000	Ø128; STD; Zestaw: 1; [T15 G6 CR 3.5] [M 3] [DSF CR 5]									
	80 00300 1 0 000	Ø128; STD; Zestaw: 1; [T15 G6 CR 4] [M 3] [DSF CR 4]									
	80 01100 1 0 000	Ø128; STD; Zestaw: 1; [T15 G6 CK 4] [M G3 CR 3] [DSF CR 4]									
	41 260 960	tłoki: 41260600; tuleja cylindrowa: 89186120									
	89 186 120	N - Mokra tuleja cylindra; skoczony; A=144.5 C=153.8 L=270 H+F=10.07+1									
	89 914 120	N - Mokra tuleja cylindra; skoczony; A=144.5 C=153.8 L=270 H+F=10.07+1, płaszcz wodny powlek. plazmowo									
	89 518 120	N - Mokra tuleja cylindra; skoczony; A=144.5 C=153.8 L=270 H+F=10.27+1									
	89 324 120	N - Mokra tuleja cylindra; skoczony; A=144.5 C=153.8 L=270 H+F=10.57+1									
	89 892 120	N - Mokra tuleja cylindra; skoczony; A=145.5 C=154.3 L=270 H+F=10.07+1									
	78 586 600	[para] HL STD Ø 104.000 / 111.000 / 36.000 / 3.478 St/B/G1 78 586 605 0,10 / 78 586 610 0,25 / 78 586 620 0,50 / 78 586 630 0,75									
	79 237 600	[para] PL STD Ø 90.000 / 95.000 / 36.200 / 2.478 St/B/G1; PL STD Ø 90.000 / 95.000 / 36.200 / 2.479 St/B/S 79 237 610 0,25 / 79 237 620 0,50 / 79 237 630 0,75 , Górna panewka jest oznakowana 'SPUTTER'.									
	79 261 600	[para] AS STD Ø 114.750 / 137.650 / / 3.400 St/A 79 261 610 0,40 / 79 261 620 0,80									
	79 444 600	[para] PL STD Ø 90.000 / 95.000 / 36.200 / 2.479 St/B/S, SPUTTER: u góry i u dołu, zastosowanie GAS									

cont...

	77 682 600	[komplet] HL STD Ø 104.000 / 111.000 / 36.000 / 3.478 St/B/G1 77 682 610 0,25 / 77 682 620 0,50
	77 682 700	[komplet] HL STD Ø 104.000 / 111.500 / 36.000 / 3.728 St/B/G1 77 682 710 0,25 , Nadwymiar zewnętrzny + 0,50 mm
	77 812 690	[komplet] PL-B SEMI Ø 50.000 / 54.000 / 38.700 / St/B
	87 501 600	[komplet] NW-L STD Ø 69.940 / 76.000 / 39.000 / 3.000 St/B; NW-L STD Ø 69.940 / 75.000 / 36.000 / 2.500 St/A; NW-L STD Ø 69.940 / 75.000 / 28.000 / 2.500 St/A
	20 0602 G2876	Długo: 256; rednica otworu lepego duej główki korbowodu: 95; rednica małej główki korbowodu: 50.06; Szeroko stopy korbowodu: 45.85; Szeroko łba korbowodu: 39; korbowód trapezowy; krakowany
	20 0502 28760	rednica kołnierza koła zamachowego: 113
	20 0302 28661	bez tulei cylindra
	20 0802 G2820	- V - G - S - - - - ; element gotowy do montau, Uywaj do wiecy zapłonowej M14
	20 0802 G2828	- V - G - S - - - - ; element gotowy do montau
	20 0802 G2840	- V - G - S - - - - ; element gotowy do montau, Uywaj do wiecy zapłonowej M14
	25311	EX; 51 x 12 x 142.5 x I/S - Cr - 30° - VS - 1 - III
	25324	EX; 51 x 12 x 142.5 x RA/S - Cr - 30° - 1 - III
	25310	IN; 58 x 12 x 142.5 x I/S - Cr - 30° - VS - 1 - III
	92-25004	EX; 53.1 x 43 x 7.45; G2; 30°
	92-25018	EX; 53.11 x 43 x 9.5; HWR
	92-25005	IN; 61.11 x 49 x 6.8; G2; 30°
	92-25019	IN; 61.11 x 49 x 8.8; HWR
	20 1002 G2866	
	20 1402 28760	
	20 1402 28761	
	20 1902 28420	Długo: 250; Szeroko: 78; Wysoko: 197; Masa: 6.75 g
20	 128	
	G 2876 Euro 5	DUH 01
		01.2005 → 12.2014 G NA 6 12816 cm ³ 12V 200 kW 272 PS € 10.0 166
	G 2876	DUH 02
		01.2005 → 12.2014 G NA 6 12816 cm ³ 12V 200 kW 272 PS € 10.0 166
	LION'S CITY, NL	
	80 01269 1 0 000	Ø128
	89 186 120	N - Mokra tuleja cylindra; skoczony; A=144.5 C=153.8 L=270 H+F=10.07+1
	89 914 120	N - Mokra tuleja cylindra; skoczony; A=144.5 C=153.8 L=270 H+F=10.07+1, płaszcz wodny powlek. plazmowo
	89 518 120	N - Mokra tuleja cylindra; skoczony; A=144.5 C=153.8 L=270 H+F=10.27+1
	89 324 120	N - Mokra tuleja cylindra; skoczony; A=144.5 C=153.8 L=270 H+F=10.57+1
	89 892 120	N - Mokra tuleja cylindra; skoczony; A=145.5 C=154.3 L=270 H+F=10.07+1
	79 237 600	[para] PL STD Ø 90.000 / 95.000 / 36.200 / 2.478 St/B/G1; PL STD Ø 90.000 / 95.000 / 36.200 / 2.479 St/B/S 79 237 610 0,25 / 79 237 620 0,50 / 79 237 630 0,75 , Górna panewka jest oznakowana 'SPUTTER'.
	79 261 600	[para] AS STD Ø 114.750 / 137.650 // 3.400 St/A 79 261 610 0,40 / 79 261 620 0,80 , 06.1999→
	79 341 600	[para] HL STD Ø 104.000 / 111.000 / 36.000 / 3.478 St/B/G1; HL STD Ø 104.000 / 111.000 / 36.000 / 3.478 St/B/S 79 341 610 0,25 / 79 341 620 0,50 , Dolna panewka jest oznakowana 'SPUTTER'.
	79 444 600	[para] PL STD Ø 90.000 / 95.000 / 36.200 / 2.479 St/B/S, SPUTTER: u góry i u dołu, zastosowanie GAS
	77 812 690	[komplet] PL-B SEMI Ø 50.000 / 54.000 / 38.700 / St/B
	87 501 600	[komplet] NW-L STD Ø 69.940 / 76.000 / 39.000 / 3.000 St/B; NW-L STD Ø 69.940 / 75.000 / 36.000 / 2.500 St/A; NW-L STD Ø 69.940 / 75.000 / 28.000 / 2.500 St/A
	20 0602 G2876	Długo: 256; rednica otworu lepego duej główki korbowodu: 95; rednica małej główki korbowodu: 50.06; Szeroko stopy korbowodu: 45.85; Szeroko łba korbowodu: 39; korbowód trapezowy; krakowany

cont...

	20 0502 28760	rednica kołnierza koła zamachowego: 113	
	20 0302 28661	bez tulei cylindra	
	25311	EX; 51 x 12 x 142.5 x I/S - Cr - 30° - VS - 1 - III	 KK-12H stoek zaworu; Liczba karbów: 1; rednica trzonka zaworu: 12
	25324	EX; 51 x 12 x 142.5 x RA/S - Cr - 30° - 1 - III	 81-25102 EX; 18/ x 12.02 x 56 G2
	25310	IN; 58 x 12 x 142.5 x I/S - Cr - 30° - VS - 1 - III	 81-25107 EX; 18.2/ x 12.02 x 56 G2
	92-25004	EX; 53.1 x 43 x 7.45; G2; 30°	81-25101 IN; 18/ x 12.02 x 59.5 G2
	92-25018	EX; 53.11 x 43 x 9.5; HWR	81-2536 IN/EX; 18/ x 12 x 64 G2, W przypadku stosowania gazu uywa tylko w obszarze dolotu.
	92-25005	IN; 61.11 x 49 x 6.8; G2; 30°	81-2537 IN/EX; 18.2/ x 12 x 64 G2, W przypadku stosowania gazu uywa tylko w obszarze dolotu.
	92-25019	IN; 61.11 x 49 x 8.8; HWR	81-2538 IN/EX; 18.4/ x 12 x 64 G2, W przypadku stosowania gazu uywa tylko w obszarze dolotu.
	20 1002 G2866		
	20 1602 28661	mech.; rednica wirnika pompy: 135, do retardera	 20 1402 28760
	20 1902 28760	Długo: 250; Szeroko: 78; Wysoko: 111; Masa: 3 g	
	20 1002 25020	wspornik dwigienki zaworowej, tylko 2-zaworowy	

21

128

E 2842

E

G 12 21930 cm³ 2V 177 kW 241 PS  142



40 208 600



Ø cylindra: 128; KH: 80.7; MT: -28.2; MØ: 94; GL: 129.7; sworze tłokowy: 46x105; Liczba pierieni: 3

RTK

T15 3.5 CR G6

M 3

DSF 5 CR

→ **80 00155 1 0 ...**



42 043 600



Ø cylindra: 128; KH: 80.7; MT: -21.7; MØ: 90; GL: 129.7; sworze tłokowy: 46x105; Liczba pierieni: 3

RTK

T15 3.5 CR G6

M 3

DSF 5 CR

→ **80 00155 1 0 ...**

94 942 600



Ø cylindra: 128; KH: 80.7; MT: -29; MØ: 96; GL: 130; sworze tłokowy: 46x105; Liczba pierieni: 3

FBo, RTK

T15 3.5 CR G6

M 3

DSF 5 CR

→ **80 00155 1 0 ...**



Stopie sprania 10:1

94 943 600



Ø cylindra: 128; KH: 80.7; MT: -22; MØ: 96; GL: 130; sworze tłokowy: 46x105; Liczba pierieni: 3

FBo, RTK

T15 3.5 CR G6

M 3

DSF 5 CR

→ **80 00155 1 0 ...**



80 00155 1 0 000

Ø128; STD; Zestaw: 1; [T15 G6 CR 3.5] [M 3] [DSF CR 5]











42 043 960

tłoki: 42043600; tuleja cylindrowa: 89092120

94 943 960









tłoki: 94943600; tuleja cylindrowa: 89092120

cont...









	89 092 120	N - Mokra tuleja cylindra; skoczony; A=144.5 C=153.8 L=253 H+F=10.05+1
	78 693 600	[para] HL STD Ø 104.000 / 111.000 / 30.500 / 3.472 St/B/G1 78 693 610 0,25 / 78 693 620 0,50 / 78 693 630 0,75 / 78 693 640 1,00
	78 694 604	[para] PASS-L STD Ø 104.000 / 111.000 / 37.810 / 3.474 St/B/G 78 694 614 0,25 / 78 694 624 0,50 / 78 694 634 0,75 / 78 694 644 1,00
	78 897 600	[para] PL STD Ø 90.000 / 95.000 / 31.000 / 2.473 St/B/S; PL STD Ø 90.000 / 95.000 / 31.000 / 2.473 St/B/G1 78 897 605 0,10 / 78 897 610 0,25 / 78 897 620 0,50 / 78 897 630 0,75 / 78 897 640 1,00 , Górna panewka jest oznakowana 'SPUTTER'.
	79 443 600	[para] PL STD Ø 90.000 / 95.000 / 31.000 / 2.473 St/B/S, SPUTTER: u góry i u dołu, zastosowanie GAS
	87 346 690	[komplet] PL-B SEMI Ø 46.000 / 50.600 / 38.700 / St/B
	87 366 600	[komplet] NW-L STD Ø 69.940 / 76.000 / 35.000 / 3.000 St/B; NW-L STD Ø 69.940 / 75.000 / 28.000 / 2.500 St/A
	87 397 604	[komplet] HL STD Ø 104.000 / 111.000 / 30.500 / 3.472 St/B/G1; PASS-L STD Ø 104.000 / 111.000 / 37.810 / 3.474 St/B/G 87 397 614 0,25 / 87 397 624 0,50
	20 0602 G2801	Długo: 256; rednica otworu lepego deuj główki korbowodu: 95; rednica małej główki korbowodu: 46; Szeroko stopy korbowodu: 33; Szeroko łba korbowodu: 39; korbowód trapezowy; krakowany
	20 0302 28420	bez tulei cylindra
	20 0802 G2820	- V - G - S - - - - -; element gotowy do montau, Uywaj do wiecy zapłonowej M14
	20 0802 G2828	- V - G - S - - - - -; element gotowy do montau
	20 0802 G2840	- V - G - S - - - - -; element gotowy do montau, Uywaj do wiecy zapłonowej M14
	25311	EX; 51 x 12 x 142.5 x I/S - Cr - 30° - VS - 1 - III
	25324	EX; 51 x 12 x 142.5 x RA/S - Cr - 30° - 1 - III
	25310	IN; 58 x 12 x 142.5 x I/S - Cr - 30° - VS - 1 - III
	92-25004	EX; 53.1 x 43 x 7.45; G2; 30°
	92-25018	EX; 53.11 x 43 x 9.5; HWR
	92-25005	IN; 61.11 x 49 x 6.8; G2; 30°
	92-25019	IN; 61.11 x 49 x 8.8; HWR
	20 1403 44300	

	81-25103	EX; 18/ x 12 x 70 G2, Długo rowka olejowego jest różna w zalenoci od głowicy! 81-25103 ma krótki rowek olejowy. Dopiero po wymontowaniu przewodnicy zaworu mona stwierdzi jej wersj. Nie mona odróni wersji po numerach silnika.
	81-25113	EX; 18/ x 12.01 x 70 G2
	81-25102	EX; 18/ x 12.02 x 56 G2
	81-25101	IN; 18/ x 12.02 x 59.5 G2
	81-2536	IN/EX; 18/ x 12 x 64 G2, W przypadku stosowania gazu uywa tylko w obszarze dolotu.

M







22		128
	E 2842	LE 202
		G LA 12 21930 cm ³ 2V
		 142
	41 000 600	Ø cylindra: 128; KH: 80.7; MT: -26; MØ: 91.6; GL: 129.7; sworze tłokowy: 46x105; Liczba piercieni: 3 RTK T15 4 CK G6 M 3 CR G3 DSF 4 CR → 80 01100 1 0 ...
	42 043 600	Ø cylindra: 128; KH: 80.7; MT: -21.7; MØ: 90; GL: 129.7; sworze tłokowy: 46x105; Liczba piercieni: 3 RTK T15 3.5 CR G6 M 3 DSF 5 CR → 80 00155 1 0 ...
	80 00155 1 0 000	Ø128; STD; Zestaw: 1; [T15 G6 CR 3.5] [M 3] [DSF CR 5]
	80 00717 1 0 000	Ø128; STD; Zestaw: 1; [T15 G6 CK 4] [M G3 3] [DSF CR 4]
	80 01100 1 0 000	Ø128; STD; Zestaw: 1; [T15 G6 CK 4] [M G3 CR 3] [DSF CR 4]
	42 043 960	tłoki: 42043600; tuleja cylindrowa: 89092120
	89 092 120	N - Mokra tuleja cylindra; skoczony; A=144.5 C=153.8 L=253 H+F=10.05+1

cont...















	78 693 600	[para] HL STD Ø 104.000 / 111.000 / 30.500 / 3.472 St/B/G1 78 693 610 0,25 / 78 693 620 0,50 / 78 693 630 0,75 / 78 693 640 1,00
	78 694 604	[para] PASS-L STD Ø 104.000 / 111.000 / 37.810 / 3.474 St/B/G 78 694 614 0,25 / 78 694 624 0,50 / 78 694 634 0,75 / 78 694 644 1,00
	78 709 600	[para] PL-L STD Ø 31.975 / 36.000 / 19.000 / 2.011 St/B/G, Do sprarek powietrza z tłokami Ø 90 mm.
	78 897 600	[para] PL STD Ø 90.000 / 95.000 / 31.000 / 2.473 St/B/S; PL STD Ø 90.000 / 95.000 / 31.000 / 2.473 St/B/G1 78 897 605 0,10 / 78 897 610 0,25 / 78 897 620 0,50 / 78 897 630 0,75 / 78 897 640 1,00, Górna panewka jest oznakowana 'SPUTTER'.
	79 443 600	[para] PL STD Ø 90.000 / 95.000 / 31.000 / 2.473 St/B/S, SPUTTER: u góry i u dołu, zastosowanie GAS
	87 346 690	[komplet] PL-B SEMI Ø 46.000 / 50.600 / 38.700 / St/B
	87 366 600	[komplet] NW-L STD Ø 69.940 / 76.000 / 35.000 / 3.000 St/B; NW-L STD Ø 69.940 / 75.000 / 28.000 / 2.500 St/A
	87 397 604	[komplet] HL STD Ø 104.000 / 111.000 / 30.500 / 3.472 St/B/G1; PASS-L STD Ø 104.000 / 111.000 / 37.810 / 3.474 St/B/G 87 397 614 0,25 / 87 397 624 0,50
	20 0602 G2801	Długo: 256; rednica otworu lepego dnej główki korbowodu: 95; rednica małej główki korbowodu: 46; Szeroko stopy korbowodu: 33; Szeroko łba korbowodu: 39; korbowód trapezowy; krakowany
	20 0302 28420	bez tulei cylindra
	20 0802 G2820	- V - G - S - - - - ; element gotowy do montau, Uywaj do wiecey zapłonowej M14
	20 0802 G2828	- V - G - S - - - - ; element gotowy do montau
	20 0802 G2840	- V - G - S - - - - ; element gotowy do montau, Uywaj do wiecey zapłonowej M14
	25311	EX; 51 x 12 x 142.5 x I/S - Cr - 30° - VS - 1 - III
	25324	EX; 51 x 12 x 142.5 x RA/S - Cr - 30° - 1 - III
	25310	IN; 58 x 12 x 142.5 x I/S - Cr - 30° - VS - 1 - III
	92-25004	EX; 53.1 x 43 x 7.45; G2; 30°
	92-25018	EX; 53.11 x 43 x 9.5; HWR
	92-25005	IN; 61.11 x 49 x 6.8; G2; 30°
	92-25019	IN; 61.11 x 49 x 8.8; HWR
	20 1403 44300	
	20 1403 44400	
	20 1902 28420	Długo: 250; Szeroko: 78; Wysoko: 197; Masa: 6.75 g, 02.2000→

	81-25103	EX; 18/ x 12 x 70 G2, Długo rowka olejowego jest różna w zależności od główki! 81-25103 ma krótki rowek olejowy. Dopiero po wymontowaniu przewodnicy zaworu można stwierdzić jej wersję. Nie można odróżnić wersji po numerach silnika.
	81-25113	EX; 18/ x 12.01 x 70 G2
	81-2536	IN/EX; 18/ x 12 x 64 G2, W przypadku stosowania gazu używać tylko w obszarze dolotu.
	81-2537	IN/EX; 18.2/ x 12 x 64 G2, W przypadku stosowania gazu używać tylko w obszarze dolotu.
	81-2538	IN/EX; 18.4/ x 12 x 64 G2, W przypadku stosowania gazu używać tylko w obszarze dolotu.

M

23		128
	E 2842	LE 302
		G LA 12 21930 cm ³ 2V 
	40 208 600	Ø cylindra: 128; KH: 80.7; MT: -28.2; MØ: 94; GL: 129.7; sworze tłokowy: 46x105; Liczba pierścieni: 3 RTK T15 3.5 CR G6 M 3 DSF 5 CR → 80 00155 1 0 ...
	41 000 600	Ø cylindra: 128; KH: 80.7; MT: -26; MØ: 91.6; GL: 129.7; sworze tłokowy: 46x105; Liczba pierścieni: 3 RTK T15 4 CK G6 M 3 CR G3 DSF 4 CR → 80 01100 1 0 ...
		

cont...

42 043 600	 <p>Ø cylindra: 128; KH: 80.7; MT: -21.7; MØ: 90; GL: 129.7; sworze tłokowy: 46x105; Liczba pierścieni: 3 RTK T15 3.5 CR G6 M 3 DSF 5 CR → 80 00155 1 0 ...</p>
94 943 600	 <p>Ø cylindra: 128; KH: 80.7; MT: -22; MØ: 96; GL: 130; sworze tłokowy: 46x105; Liczba pierścieni: 3 FBo, RTK T15 3.5 CR G6 M 3 DSF 5 CR → 80 00155 1 0 ...</p>
	80 00155 1 0 000 Ø128; STD; Zestaw: 1; [T15 G6 CR 3.5] [M 3] [DSF CR 5]
80 00717 1 0 000	Ø128; STD; Zestaw: 1; [T15 G6 CK 4] [M G3 3] [DSF CR 4]
80 01100 1 0 000	Ø128; STD; Zestaw: 1; [T15 G6 CK 4] [M G3 CR 3] [DSF CR 4]
	42 043 960 tłoki: 42043600; tuleja cylindrowa: 89092120
94 943 960	tłoki: 94943600; tuleja cylindrowa: 89092120
	89 092 120 N - Mokra tuleja cylindra; skoczony; A=144.5 C=153.8 L=253 H+F=10.05+1
89 093 120	N - Mokra tuleja cylindra; skoczony; A=145 C=154.3 L=253 H+F=10.05+1
	78 693 600 [para] HL STD Ø 104.000 / 111.000 / 30.500 / 3.472 St/B/G1 78 693 610 0,25 / 78 693 620 0,50 / 78 693 630 0,75 / 78 693 640 1,00
78 694 604	[para] PASS-L STD Ø 104.000 / 111.000 / 37.810 / 3.474 St/B/G 78 694 614 0,25 / 78 694 624 0,50 / 78 694 634 0,75 / 78 694 644 1,00
78 709 600	[para] PL-L STD Ø 31.975 / 36.000 / 19.000 / 2.011 St/B/G, Do sprarek powietrza z tłokami Ø 90 mm.
78 897 600	[para] PL STD Ø 90.000 / 95.000 / 31.000 / 2.473 St/B/S; PL STD Ø 90.000 / 95.000 / 31.000 / 2.473 St/B/G1 78 897 605 0,10 / 78 897 610 0,25 / 78 897 620 0,50 / 78 897 630 0,75 / 78 897 640 1,00, Górna panewka jest oznakowana 'SPUTTER'.
79 443 600	[para] PL STD Ø 90.000 / 95.000 / 31.000 / 2.473 St/B/S, SPUTTER: u góry i u dołu, zastosowanie GAS
87 346 690	[komplet] PL-B SEMI Ø 46.000 / 50.600 / 38.700 / St/B
87 366 600	[komplet] NW-L STD Ø 69.940 / 76.000 / 35.000 / 3.000 St/B; NW-L STD Ø 69.940 / 75.000 / 28.000 / 2.500 St/A
87 397 604	[komplet] HL STD Ø 104.000 / 111.000 / 30.500 / 3.472 St/B/G1; PASS-L STD Ø 104.000 / 111.000 / 37.810 / 3.474 St/B/G 87 397 614 0,25 / 87 397 624 0,50
	20 0602 G2801 Długo: 256; rednica otworu lepego duej główki korbowodu: 95; rednica małej główki korbowodu: 46; Szeroko stopy korbowodu: 33; Szeroko łba korbowodu: 39; korbowód trapezowy; krakowany
	20 0302 28420 bez tulei cylindra
	20 0802 G2820 - V - G - S - - - -; element gotowy do montau, Uywaj do wiecy zapłonowej M14
20 0802 G2828	- V - G - S - - - -; element gotowy do montau
20 0802 G2840	- V - G - S - - - -; element gotowy do montau, Uywaj do wiecy zapłonowej M14
	25311 EX; 51 x 12 x 142.5 x I/S - Cr - 30° - VS - 1 - III
25324	EX; 51 x 12 x 142.5 x RA/S - Cr - 30° - 1 - III
25310	IN; 58 x 12 x 142.5 x I/S - Cr - 30° - VS - 1 - III
	92-25004 EX; 53.1 x 43 x 7.45; G2; 30°
92-25018	EX; 53.11 x 43 x 9.5; HWR
92-25005	IN; 61.11 x 49 x 6.8; G2; 30°
92-25019	IN; 61.11 x 49 x 8.8; HWR
	KK-12H stoek zaworu; Liczba karbów: 1; rednica trzonka zaworu: 12
	81-25103 EX; 18/ x 12 x 70 G2, Długo rowka olejowego jest róna w zalenoci od główicy! 81-25103 ma krótki rowek olejowy. Dopiero po wymontowaniu przewodnicy zaworu mona stwierdzi jej wersj. Nie mona odróni wersji po numerach silnika.
81-25107	EX; 18.2/ x 12.02 x 56 G2
81-25101	IN; 18/ x 12.02 x 59.5 G2
81-2536	IN/EX; 18/ x 12 x 64 G2, W przypadku stosowania gazu uywa tylko w obszarze dolotu.
81-2537	IN/EX; 18.2/ x 12 x 64 G2, W przypadku stosowania gazu uywa tylko w obszarze dolotu.
81-2538	IN/EX; 18.4/ x 12 x 64 G2, W przypadku stosowania gazu uywa tylko w obszarze dolotu.
	20 1403 44300 20 1403 44400
	20 1902 28420 Długo: 250; Szeroko: 78; Wysoko: 197; Masa: 6.75 g, 02.2000→



41 000 600 Ø cylindra: 128; KH: 80.7; MT: -26; MØ: 91.6; GL: 129.7; sworze tłokowy: 46x105; Liczba pierścieni: 3
RTK
T15 4 CK G6
M 3 CR G3
DSF 4 CR
→ **80 01100 1 0 ...**

42 043 600



Ø cylindra: 128; KH: 80.7; MT: -21.7; MØ: 90; GL: 129.7; sworze tłokowy: 46x105; Liczba pierścieni: 3
RTK
T15 3.5 CR G6
M 3
DSF 5 CR

94 943 600



Ø cylindra: 128; KH: 80.7; MT: -22; MØ: 96; GL: 130; sworze tłokowy: 46x105; Liczba pierścieni: 3
FBo, RTK
T15 3.5 CR G6
M 3
DSF 5 CR



80 00717 1 0 000 Ø128; STD; Zestaw: 1; [T15 G6 CK 4] [M G3 3] [DSF CR 4]

80 01100 1 0 000 Ø128; STD; Zestaw: 1; [T15 G6 CK 4] [M G3 CR 3] [DSF CR 4]



41 000 960 tłoki: 41000600; tuleja cylindrowa: 89092120

42 043 960 tłoki: 42043600; tuleja cylindrowa: 89092120

94 943 960 tłoki: 94943600; tuleja cylindrowa: 89092120



89 092 120 N - Mokra tuleja cylindra; skoczony; A=144.5 C=153.8 L=253 H+F=10.05+1

89 093 120 N - Mokra tuleja cylindra; skoczony; A=145 C=154.3 L=253 H+F=10.05+1

M



78 693 600 [para] HL STD Ø 104.000 / 111.000 / 30.500 / 3.472 St/B/G1
78 693 610 0,25 / 78 693 620 0,50 / 78 693 630 0,75 / 78 693 640 1,00

78 694 604 [para] PASS-L STD Ø 104.000 / 111.000 / 37.810 / 3.474 St/B/G

78 694 614 0,25 / 78 694 624 0,50 / 78 694 634 0,75 / 78 694 644 1,00

78 709 600 [para] PL-L STD Ø 31.975 / 36.000 / 19.000 / 2.011 St/B/G, Do sprarek powietrza z tłokami Ø 90 mm.

78 897 600 [para] PL STD Ø 90.000 / 95.000 / 31.000 / 2.473 St/B/S; PL STD Ø 90.000 / 95.000 / 31.000 / 2.473 St/B/G1
78 897 605 0,10 / 78 897 610 0,25 / 78 897 620 0,50 / 78 897 630 0,75 / 78 897 640 1,00, Górna panewka jest oznakowana 'SPUTTER'.

79 443 600 [para] PL STD Ø 90.000 / 95.000 / 31.000 / 2.473 St/B/S, SPUTTER: u góry i u dołu, zastosowanie GAS

87 346 690 [komplet] PL-B SEMI Ø 46.000 / 50.600 / 38.700 / St/B

87 366 600 [komplet] NW-L STD Ø 69.940 / 76.000 / 35.000 / 3.000 St/B; NW-L STD Ø 69.940 / 75.000 / 28.000 / 2.500 St/A

87 397 604 [komplet] HL STD Ø 104.000 / 111.000 / 30.500 / 3.472 St/B/G1; PASS-L STD Ø 104.000 / 111.000 / 37.810 / 3.474 St/B/G
87 397 614 0,25 / 87 397 624 0,50



20 0602 G2801 Długo: 256; rednica otworu lepego duej główki korbowodu: 95; rednica małej główki korbowodu: 46; Szeroko stopy korbowodu: 33; Szeroko łba korbowodu: 39; korbowód trapezowy; krakowany



20 0302 28420 bez tulei cylindra



20 0802 G2820 - V - G - S - - - - -; element gotowy do montau, Uywaj do wiecey zapłonowej M14

20 0802 G2828 - V - G - S - - - - -; element gotowy do montau

20 0802 G2840 - V - G - S - - - - -; element gotowy do montau, Uywaj do wiecey zapłonowej M14



25311 EX; 51 x 12 x 142.5 x I/S - Cr - 30° - VS - 1 - III



25324 EX; 51 x 12 x 142.5 x RA/S - Cr - 30° - 1 - III



25310 IN; 58 x 12 x 142.5 x I/S - Cr - 30° - VS - 1 - III



KK-12H stoek zaworu; Liczba karbów: 1; rednica trzonka zaworu: 12



81-25103 EX; 18./ x 12 x 70 G2, Długo rowka olejowego jest różna w zalenoci od główicy!
81-25103 ma krótki rowek olejowy. Dopiero po wymontowaniu przewodnicy zaworu mona stwierdzi jej wersj. Nie mona odróni wersji po numerach silnika.
81-25107 EX; 18.2/ x 12.02 x 56 G2

cont...

	92-25004	EX; 53.1 x 43 x 7.45; G2; 30°	81-25101	IN; 18/ x 12.02 x 59.5 G2
	92-25018	EX; 53.11 x 43 x 9.5; HWR	81-2536	IN/EX; 18/ x 12 x 64 G2, W przypadku stosowania gazu uywa tylko w obszarze dolotu.
	92-25005	IN; 61.11 x 49 x 6.8; G2; 30°	81-2537	IN/EX; 18.2/ x 12 x 64 G2, W przypadku stosowania gazu uywa tylko w obszarze dolotu.
	92-25019	IN; 61.11 x 49 x 8.8; HWR	81-2538	IN/EX; 18.4/ x 12 x 64 G2, W przypadku stosowania gazu uywa tylko w obszarze dolotu.

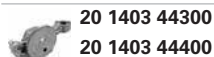

20 1403 44300
20 1403 44400



20 1902 28420 Długo: 250; Szeroko: 78; Wysoko: 197; Masa: 6.75 g, 02.2000→

25



132



E 3262

E 203

G LA 12 25782 cm³ 4V 550 kW 748 PS ξ 12:1 157

E 3262

E 302, LE 242

G NA 12 25782 cm³ 48V 275-580 kW 374-789 PS ξ 12.0 157



89 955 110 N - Mokra tuleja cylindra; skoczony; A=149.5 C=163.3 L=262 H=10.06



25323 EX; 42 x 9 x 153.7 x I/S - Cr - 30° - VS - 22 - III

25322 IN; 44 x 9 x 153.7 x RA/S - Cr - 30° - 22 - III



MK-9H

stoek zaworu; Liczba karbów: 3; rednica trzonka zaworu: 9



81-25112

IN/EX; 15.03/ x 9 x 66.5 G2, dodatkowe napunktowanie na rednicy uszczelnienia trzonka zaworu



92-25025 EX; 44.043 x 35.7 x 7.8; G4; 30°

92-25024 IN; 46.043 x 37.3 x 7.8; G5; 30°

26



132



E 3262

LE 202

G LA 12 25782 cm³ 48V 550-580 kW 748-789 PS ξ 12.0 157

E 3262

LE 222

G NA 12 25782 cm³ 48V 500 kW 680 PS ξ 12.0 157

E 3268

LE 212

G LA 1 17188 cm³ 16V 370-390 kW 503-530 PS ξ 12 157

E 3268

LE 212, LE 222, LE 222, LE 232

G LA 8 17188 cm³ 16V 370-530 kW 503-530 PS 157



42 089 600 \varnothing cylindra: 132; KH: 78.5; MT: -28; M \varnothing : 90.3; GL: 125; sworze tłokowy: 55x99; Liczba pierścieni: 3
RTK, KBB

T15 3.5 CK G6

M 2.5 CR

DSF 3.5 CR

→ **80 01265 1 0 ...**

42 090 600 \varnothing cylindra: 132; KH: 78.5; MT: -25.3; M \varnothing : 86.4; GL: 125; sworze tłokowy: 55x99; Liczba pierścieni: 3
RTK, KBB

T15 3.5 CK G6

M 2.5 CR

DSF 3.5 CR

→ **80 01265 1 0 ...**



80 01265 1 0 000 \varnothing 132; STD; Zestaw: 1; [T15 G6 CK 3.5] [M CR 2.5] [DSF CR 3.5]



89 955 110 N - Mokra tuleja cylindra; skoczony; A=149.5 C=163.3 L=262 H=10.06



25323 EX; 42 x 9 x 153.7 x I/S - Cr - 30° - VS - 22 - III

25322 IN; 44 x 9 x 153.7 x RA/S - Cr - 30° - 22 - III



MK-9H

stoek zaworu; Liczba karbów: 3; rednica trzonka zaworu: 9





81-25112



IN/EX; 15.03/ x 9 x 66.5 G2, dodatkowe napunktowanie na rednicy uszczelnienia trzonka zaworu









92-25025 EX; 44.043 x 35.7 x 7.8; G4; 30°









92-25024 IN; 46.043 x 37.3 x 7.8; G5; 30°



27		132	
	E 3262	LE 232	G 1 25782 cm ³ 48V 450 kW 612 PS € 12 157
	E 3262	LE 202, LE 212, LE 222	G 12 25782 cm ³ 48V 500-580 kW 680-789 PS € 12 157
	E 3268	LE 232	G LA 8 17188 cm ³ 16V 370 kW 503 PS € 12 157
	42 089 600	Ø cylindra: 132; KH: 78.5; MT: -28; MØ: 90.3; GL: 125; sworze tłokowy: 55x99; Liczba pierścieni: 3 RTK, KBB T15 3.5 CK G6 M 2.5 CR DSF 3.5 CR	
	42 090 600	Ø cylindra: 132; KH: 78.5; MT: -25.3; MØ: 86.4; GL: 125; sworze tłokowy: 55x99; Liczba pierścieni: 3 RTK, KBB T15 3.5 CK G6 M 2.5 CR DSF 3.5 CR	

28		132	
	E 3262	LE 212	G NA 12 25782 cm ³ 48V 550-580 kW 748-789 PS € 12.0 157
	42 089 600	Ø cylindra: 132; KH: 78.5; MT: -28; MØ: 90.3; GL: 125; sworze tłokowy: 55x99; Liczba pierścieni: 3 RTK, KBB T15 3.5 CK G6 M 2.5 CR DSF 3.5 CR → 80 01265 1 0 ...	
	42 090 600	Ø cylindra: 132; KH: 78.5; MT: -25.3; MØ: 86.4; GL: 125; sworze tłokowy: 55x99; Liczba pierścieni: 3 RTK, KBB T15 3.5 CK G6 M 2.5 CR DSF 3.5 CR → 80 01265 1 0 ...	

M

	80 01265 1 0 000	Ø132; STD; Zestaw: 1; [T15 G6 CK 3.5] [M CR 2.5] [DSF CR 3.5]	
	89 955 110	N - Mokra tuleja cylindra; skoczony; A=149.5 C=163.3 L=262 H=10.06	
	MK-9H	stoek zaworu; Liczba karbów: 3; rednica trzonka zaworu: 9	 81-25112 IN/EX; 15.03/ x 9 x 66.5 G2, dodatkowe napunktowanie na rednicy uszczelnienia trzonka zaworu
	92-25025	EX; 44.043 x 35.7 x 7.8; G4; 30°	
	92-25024	IN; 46.043 x 37.3 x 7.8; G5; 30°	

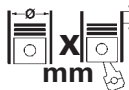
29		132	
	E 3262	LE 232	G NA 12 25782 cm ³ 48V 450-580 kW 612-789 PS € 12.0 157
	42 089 600	Ø cylindra: 132; KH: 78.5; MT: -28; MØ: 90.3; GL: 125; sworze tłokowy: 55x99; Liczba pierścieni: 3 RTK, KBB T15 3.5 CK G6 M 2.5 CR DSF 3.5 CR	
	42 090 600	Ø cylindra: 132; KH: 78.5; MT: -25.3; MØ: 86.4; GL: 125; sworze tłokowy: 55x99; Liczba pierścieni: 3 RTK, KBB T15 3.5 CK G6 M 2.5 CR DSF 3.5 CR	
	89 955 110	N - Mokra tuleja cylindra; skoczony; A=149.5 C=163.3 L=262 H=10.06	
	25323	EX; 42 x 9 x 153.7 x I/S - Cr - 30° - VS - 22 - III	 MK-9H stoek zaworu; Liczba karbów: 3; rednica trzonka zaworu: 9
	25322	IN; 44 x 9 x 153.7 x RA/S - Cr - 30° - 22 - III	 81-25112 IN/EX; 15.03/ x 9 x 66.5 G2, dodatkowe napunktowanie na rednicy uszczelnienia trzonka zaworu
	92-25025	EX; 44.043 x 35.7 x 7.8; G4; 30°	
	92-25024	IN; 46.043 x 37.3 x 7.8; G5; 30°	

	Cyl.	 mm	cm ³		Comp. Ratio ε	kW	PS	Pos
GS12R-MPTK	G (LA) 12	170 x 180	49028	48	15.0	700-721	952-980	1
GS12R-PTK	G (LA) 12	170 x 180	49028	48	15.0	632-722	859-982	1
GS16R-MPTK	G (LA) 16	170 x 180	65370	64	15.0	930-959	1264-1304	1
GS16R-PTK	G (LA) 16	170 x 180	65370	64	15.0	845-959	1149-1304	1
GS16R2-MPTK	G (LA) 16	170 x 220	79897	64	15.0	1000-1031	1360-1402	1
GS16R2-PTK	G (LA) 16	170 x 220	79897	64	15.0	1031-1563	1402-2125	1
GS6R-MPTK	G (LA) 6	170 x 180	24514	24	15.0	305-368	415-500	1
GS6R-PTK	G (LA) 6	170 x 180	24514	24	15.0	315-363	428-494	1
GS6R2-MPTK	G (LA) 6	170 x 220	29961	24	13.9	315-394	428-536	1
GS6R2-PTK	G (LA) 6	170 x 220	29961	24	11.0	394	536	1

1

 170



GS12R-MPTK	G LA 12	49028 cm ³	48V	700-721 kW	952-980 PS	£ 15.0	 180
GS12R-PTK	G LA 12	49028 cm ³	48V	632-722 kW	859-982 PS	£ 15.0	 180
GS16R-MPTK	G LA 16	65370 cm ³	64V	930-959 kW	1264-1304 PS	£ 15.0	 180
GS16R-PTK	G LA 16	65370 cm ³	64V	845-959 kW	1149-1304 PS	£ 15.0	 180
GS16R2-MPTK	G LA 16	79897 cm ³	64V	1000-1031 kW	1360-1402 PS	£ 15.0	 220
GS16R2-PTK	G LA 16	79897 cm ³	64V	1031-1563 kW	1402-2125 PS	£ 15.0	 220
GS6R-MPTK	G LA 6	24514 cm ³	24V	305-368 kW	415-500 PS	£ 15.0	 180
GS6R-PTK	G LA 6	24514 cm ³	24V	315-363 kW	428-494 PS	£ 15.0	 180
GS6R2-MPTK	G LA 6	29961 cm ³	24V	315-394 kW	428-536 PS	£ 13.9	 220
GS6R2-PTK	G LA 6	29961 cm ³	24V	394 kW	536 PS	£ 11.0	 220



829901

IN/EX; 56.95 x 10 x 205 x RA/S - Cr - 30° - VS - 15 - III





81-75002

IN/EX; 18.03/ x 9.8 x 100 G2



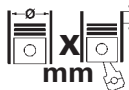

92-75000

60.08 x 49 x 8; ; 25°

	Cyl.		cm ³		Comp. Ratio ε	kW	PS	Pos
								mm
E 3042 D	G (LA) 12	130 x 142	22617					6
E 3042 L	G (LA) 12	130 x 142	22617	48	13,5:1			7
E 3042 LH	G (LA) 12	130 x 142	22617		13,5:1			8
E 3042 Z	G (LA) 12	130 x 142	22617		13,5:1			8
E 3042 ZH	G (LA) 12	130 x 142	22617		13,5:1			8
E 3066 Z8	G 6	130 x 155	12344					9
E2876DN	G 1	128 x 166	12816		10,0:1	140	190	1
E2876DN	G 1	128 x 166	12816		12,0:1	150	204	2
E2876NM	G 1	128 x 166	12816		10,0:1	140	190	3
E2876NM	G 1	128 x 166	12816		12,0:1	150	204	2
G 8V 183A	G 1	128 x 142	14618		12,0:1	255	347	4
G12V 183A	G 1	128 x 142	14618		12,0:1	390	530	5

M

1	 128						
 E2876DN		G	1	12816 cm ³	140 kW	190 PS	ε 10,0:1  166

 41 260 600	 	Ø cylindra: 128; KH: 78.65; MT: -26.6; MØ: 93; GL: 133.65; sworze tłokowy: 50x107; Liczba piercieni: 3 RTK T15 4 CK G6 M 3 CR G3 DSF 4 CR → 80 01100 1 0 ...
---	--	--

 80 00155 1 0 000	Ø128; STD; Zestaw: 1; [T15 G6 CR 3.5] [M 3] [DSF CR 5]
80 00300 1 0 000	Ø128; STD; Zestaw: 1; [T15 G6 CR 4] [M 3] [DSF CR 4]
80 01100 1 0 000	Ø128; STD; Zestaw: 1; [T15 G6 CK 4] [M G3 CR 3] [DSF CR 4]



 89 186 120	N - Mokra tuleja cylindra; skoczony; A=144.5 C=153.8 L=270 H+F=10.07+1
89 914 110	N - Mokra tuleja cylindra; skoczony; A=144.5 C=153.8 L=270 H+F=10.07+1, W przypadku silników na gaz, do łodzi, kolejowych i stacjonarnych oraz zasilania paliwami alternatywnymi, stosowa tylko ze specjalnym zestawem piercieni uszczelniających 50 007 891., płaszcz wodny powlekk. plazmowo

 78 587 604	[para] PASS-L STD Ø 104.000 / 111.000 / 45.810 / 3.478 St/B/G 78 587 614 0,25 / 78 587 624 0,50
79 237 600	[para] PL STD Ø 90.000 / 95.000 / 36.200 / 2.478 St/B/G1; PL STD Ø 90.000 / 95.000 / 36.200 / 2.479 St/B/S 79 237 610 0,25 / 79 237 620 0,50 / 79 237 630 0,75 , Górna panewka jest oznakowana 'SPUTTER'.
79 444 600	[para] PL STD Ø 90.000 / 95.000 / 36.200 / 2.479 St/B/S, SPUTTER: u góry i u dołu, zastosowanie GAS
77 682 600	[komplet] HL STD Ø 104.000 / 111.000 / 36.000 / 3.478 St/B/G1 77 682 610 0,25 / 77 682 620 0,50
87 501 600	[komplet] NW-L STD Ø 69.940 / 76.000 / 39.000 / 3.000 St/B; NW-L STD Ø 69.940 / 75.000 / 36.000 / 2.500 St/A; NW-L STD Ø 69.940 / 75.000 / 28.000 / 2.500 St/A

 20 0602 G2876	Długo: 256; rednica otworu lepego duej główki korbowodu: 95; rednica małej główki korbowodu: 50.06; Szeroko stopy korbowodu: 45.85; Szeroko łba korbowodu: 39; korbowód trapezowy; krakowany
--	--





 20 0502 28760	rednica kołnierza koła zamachowego: 113
--	---



 20 0302 28661	bez tulei cylindra
--	--------------------

 25311	EX; 51 x 12 x 142.5 x I/S - Cr - 30° - VS - 1 - III	 81-25113	EX; 18/ x 12.01 x 70 G2
25324	EX; 51 x 12 x 142.5 x RA/S - Cr - 30° - 1 - III	81-25102	EX; 18/ x 12.02 x 56 G2
25310	IN; 58 x 12 x 142.5 x I/S - Cr - 30° - VS - 1 - III	81-25101	IN; 18/ x 12.02 x 59.5 G2
 92-25018	EX; 53.11 x 43 x 9.5; HWR	81-2536	IN/EX; 18/ x 12 x 64 G2, W przypadku stosowania gazu uywa tylko w obszarze dolotu.
92-25019	IN; 61.11 x 49 x 8.8; HWR	81-2537	IN/EX; 18.2/ x 12 x 64 G2, W przypadku stosowania gazu uywa tylko w obszarze dolotu.
		81-2538	IN/EX; 18.4/ x 12 x 64 G2, W przypadku stosowania gazu uywa tylko w obszarze dolotu.

 20 1002 G2866	
--	--











 20 1402 28760	
--	--

2	 128						
 E2876DN		G	1	12816 cm ³	150 kW	204 PS	ε 12,0:1  166
 E2876NM		G	1	12816 cm ³	150 kW	204 PS	ε 12,0:1  166

 41 260 600	 	Ø cylindra: 128; KH: 78.65; MT: -26.6; MØ: 93; GL: 133.65; sworze tłokowy: 50x107; Liczba piercieni: 3 RTK T15 4 CK G6 M 3 CR G3 DSF 4 CR → 80 01100 1 0 ...
---	--	--

 80 00155 1 0 000	Ø128; STD; Zestaw: 1; [T15 G6 CR 3.5] [M 3] [DSF CR 5]
80 00300 1 0 000	Ø128; STD; Zestaw: 1; [T15 G6 CR 4] [M 3] [DSF CR 4]
80 01100 1 0 000	Ø128; STD; Zestaw: 1; [T15 G6 CK 4] [M G3 CR 3] [DSF CR 4]

cont..

	41 260 960	tłoki: 41260600; tuleja cylindrowa: 89186120	
	89 186 120 89 914 120	N - Mokra tuleja cylindra; skoczony; A=144.5 C=153.8 L=270 H+F=10.07+1 N - Mokra tuleja cylindra; skoczony; A=144.5 C=153.8 L=270 H+F=10.07+1, płaszcz wodny powlek. plazmowo	
	78 586 600 78 587 604	[para] HL STD Ø 104.000 / 111.000 / 36.000 / 3.478 St/B/G1 78 586 605 0,10 / 78 586 610 0,25 / 78 586 620 0,50 / 78 586 630 0,75 [para] PASS-L STD Ø 104.000 / 111.000 / 45.810 / 3.478 St/B/G 78 587 614 0,25 / 78 587 624 0,50	
	79 237 600	[para] PL STD Ø 90.000 / 95.000 / 36.200 / 2.478 St/B/G1; PL STD Ø 90.000 / 95.000 / 36.200 / 2.479 St/B/S 79 237 610 0,25 / 79 237 620 0,50 / 79 237 630 0,75 , Górna panewka jest oznakowana 'SPUTTER'.	
	79 444 600 77 682 600	[para] PL STD Ø 90.000 / 95.000 / 36.200 / 2.479 St/B/S, SPUTTER: u góry i u dołu, zastosowanie GAS [komplet] HL STD Ø 104.000 / 111.000 / 36.000 / 3.478 St/B/G1 77 682 610 0,25 / 77 682 620 0,50	
	77 682 700	[komplet] HL STD Ø 104.000 / 111.500 / 36.000 / 3.728 St/B/G1 77 682 710 0,25 , Nadwymiar zewnętrzny + 0,50 mm	
	87 501 600	[komplet] NW-L STD Ø 69.940 / 76.000 / 39.000 / 3.000 St/B; NW-L STD Ø 69.940 / 75.000 / 36.000 / 2.500 St/A; NW-L STD Ø 69.940 / 75.000 / 28.000 / 2.500 St/A	
	20 0602 G2876	Długo: 256; rednica otworu lepego dwej główki korbowodu: 95; rednica małej główki korbowodu: 50.06; Szeroko stopy korbowodu: 45.85; Szeroko łba korbowodu: 39; korbowód trapezowy; krakowany	
	20 0502 28760	rednica kołnierza koła zamachowego: 113	
	20 0302 28661	bez tulei cylindra	
	25311	EX; 51 x 12 x 142.5 x I/S - Cr - 30° - VS - 1 - III	 81-25103 EX; 18/ x 12 x 70 G2, Długo rowka olejowego jest różna w zalenoci od głowicy! 81-25103 ma krótki rowek olejowy. Dopiero po wymontowaniu przewodnicy zaworu mona stwierdzi jej wersj. Nie mona odróni wersji po numerach silnika.
	25324	EX; 51 x 12 x 142.5 x RA/S - Cr - 30° - 1 - III	81-25113 EX; 18/ x 12.01 x 70 G2
	25310	IN; 58 x 12 x 142.5 x I/S - Cr - 30° - VS - 1 - III	81-25102 EX; 18/ x 12.02 x 56 G2
	92-25018 92-25019	EX; 53.11 x 43 x 9.5; HWR IN; 61.11 x 49 x 8.8; HWR	81-25101 IN; 18/ x 12.02 x 59.5 G2 81-2536 IN/EX; 18/ x 12 x 64 G2, W przypadku stosowania gazu uywa tylko w obszarze dolotu.
	20 1002 G2866		
	20 1402 28760		

3

128



E2876NM

G

1

12816 cm³

140 kW

190 PS

ε 10,0:1

166

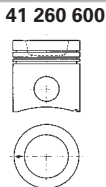

41 260 600 Ø cylindra: 128; KH: 78.65; MT: -26.6; MØ: 93; GL: 133.65; sworze tłokowy: 50x107; Liczba piercieni: 3
RTK
T15 4 CK G6
M 3 CR G3
DSF 4 CR
→ **80 01100 1 0 ...**



80 00155 1 0 000 Ø128; STD; Zestaw: 1; [T15 G6 CR 3.5] [M 3] [DSF CR 5]

80 00300 1 0 000 Ø128; STD; Zestaw: 1; [T15 G6 CR 4] [M 3] [DSF CR 4]

80 01100 1 0 000 Ø128; STD; Zestaw: 1; [T15 G6 CK 4] [M G3 CR 3] [DSF CR 4]



89 186 120 N - Mokra tuleja cylindra; skoczony; A=144.5 C=153.8 L=270 H+F=10.07+1

89 914 110 N - Mokra tuleja cylindra; skoczony; A=144.5 C=153.8 L=270 H+F=10.07+1, W przypadku silników na gaz, do łodzi, kolejowych i stacjonarnych oraz zasilania paliwami alternatywnymi, stosowa tylko ze specjalnym zestawem piercieni uszczelniających 50 007 891., płaszcz wodny powlek. plazmowo



















78 587 604 [para] PASS-L STD Ø 104.000 / 111.000 / 45.810 / 3.478 St/B/G

78 587 614 0,25 / 78 587 624 0,50







79 237 600 [para] PL STD Ø 90.000 / 95.000 / 36.200 / 2.478 St/B/G1; PL STD Ø 90.000 / 95.000 / 36.200 / 2.479 St/B/S

79 237 610 0,25 / 79 237 620 0,50 / 79 237 630 0,75, Górna panewka jest oznakowana 'SPUTTER'.



cont...

79 444 600	[para] PL STD Ø 90.000 / 95.000 / 36.200 / 2.479 St/B/S, SPUTTER: u góry i u dołu, zastosowanie GAS							
77 682 600	[komplet] HL STD Ø 104.000 / 111.000 / 36.000 / 3.478 St/B/G1 77 682 610 0,25 / 77 682 620 0,50							
87 501 600	[komplet] NW-L STD Ø 69.940 / 76.000 / 39.000 / 3.000 St/B; NW-L STD Ø 69.940 / 75.000 / 36.000 / 2.500 St/A; NW-L STD Ø 69.940 / 75.000 / 28.000 / 2.500 St/A							
 20 0602 G2876	Długo: 256; rednica otworu lepego duej główki korbowodu: 95; rednica małej główki korbowodu: 50.06; Szeroko stopy korbowodu: 45.85; Szeroko łba korbowodu: 39; korbowód trapezowy; krakowany							
 20 0502 28760	rednica kołnierza koła zamachowego: 113							
 20 0302 28661	bez tulei cylindra							
 25311	EX; 51 x 12 x 142.5 x I/S - Cr - 30° - VS - 1 - III	 81-25103	EX; 18/ x 12 x 70 G2, Długo rowka olejowego jest różna w zależności od głowicy! 81-25103 ma krótki rowek olejowy. Dopiero po wymontowaniu przewodnicy zaworu można stwierdzić jej wersję. Nie można odróżnić wersji po numerach silnika.					
25324	EX; 51 x 12 x 142.5 x RA/S - Cr - 30° - 1 - III	81-25113	EX; 18/ x 12.01 x 70 G2					
25310	IN; 58 x 12 x 142.5 x I/S - Cr - 30° - VS - 1 - III	81-25102	EX; 18/ x 12.02 x 56 G2					
 92-25018	EX; 53.11 x 43 x 9.5; HWR	81-25101	IN; 18/ x 12.02 x 59.5 G2					
 92-25019	IN; 61.11 x 49 x 8.8; HWR	81-2536	IN/EX; 18/ x 12 x 64 G2, W przypadku stosowania gazu używać tylko w obszarze dolotu.					
 20 1002 G2866								
 20 1402 28760								
4	 128							
 G 8V 183A		G	1	14618 cm ³	255 kW	347 PS	£ 12,0:1	 142
 99 803 700	Ø cylindra: 128; KH: 80.35; MT: -24; MØ: 92; GL: 125.35; sworze tłokowy: 46x105; Liczba pierścieni: 3 RTK, KBB T6 3 MO G6 M 3 CR G3 DSF 4 CR → 80 00195 1 0 ...							
 80 00195 1 0 000	Ø128; 2.00; Zestaw: 1; [T6 G6 MO 3] [M G3 IWU CR 3] [DSF CR 4]							
 89 389 110	N - Mokra tuleja cylindra; skoczony; A=144.5 C=153.8 L=253 H+F=9.92+1, W przypadku silników na gaz, do łodzi, kolejowych i stacjonarnych oraz zasilania paliwami alternatywnymi, stosować tylko ze specjalnym zestawem pierścieni uszczelniających 50 007 890.							
89 389 810	N - Mokra tuleja cylindra; skoczony; A=144.5 C=153.8 L=253 H+F=9.92+1, W przypadku silników na gaz, do łodzi, kolejowych i stacjonarnych oraz zasilania paliwami alternatywnymi, stosować tylko ze specjalnym zestawem pierścieni uszczelniających 50 007 890.							
 78 694 604	[para] PASS-L STD Ø 104.000 / 111.000 / 37.810 / 3.474 St/B/G 78 694 614 0,25 / 78 694 624 0,50 / 78 694 634 0,75 / 78 694 644 1,00							
78 897 600	[para] PL STD Ø 90.000 / 95.000 / 31.000 / 2.473 St/B/S; PL STD Ø 90.000 / 95.000 / 31.000 / 2.473 St/B/G1 78 897 605 0,10 / 78 897 610 0,25 / 78 897 620 0,50 / 78 897 630 0,75 / 78 897 640 1,00, Górna panewka jest oznakowana 'SPUTTER'.							
78 921 600	[para] HL STD Ø 104.000 / 111.000 / 30.500 / 3.472 St/B/G1; HL STD Ø 104.000 / 111.000 / 36.000 / 3.472 St/B/S 78 921 610 0,25, Dolna panewka jest oznakowana 'SPUTTER'.							
79 443 600	[para] PL STD Ø 90.000 / 95.000 / 31.000 / 2.473 St/B/S, SPUTTER: u góry i u dołu, zastosowanie GAS							
77 249 600	[komplet] HL STD Ø 104.000 / 111.000 / 36.000 / 3.472 St/B/S; HL STD Ø 104.000 / 111.000 / 30.500 / 3.472 St/B/G1; PASS-L STD Ø 104.000 / 111.000 / 37.810 / 3.474 St/B/G 77 249 610 0,25, Dolna panewka jest oznakowana 'SPUTTER'.							
87 348 690	[komplet] PL-B SEMI Ø 46.000 / 50.600 / 38.700 / St/B							
87 385 600	[komplet] NW-L STD Ø 69.940 / 76.000 / 35.000 / 3.000 St/B; NW-L STD Ø 69.940 / 75.000 / 28.000 / 2.500 St/A							

cont...

	20 0602 G2801	Długo: 256; rednica otworu lepego duej główki korbowodu: 95; rednica małej główki korbowodu: 46; Szeroko stopy korbowodu: 33; Szeroko łba korbowodu: 39; korbowód trapezowy; krakowany		
	20 0503 44201	rednica kołnierza koła zamachowego: 113		
	20 0303 44200	bez tulei cylindra		
	16150	EX; 51 x 12 x 142.5 x RA/S - Cr - 45° - 5 - III	 81-16100	IN/EX; 18.03/ x 12 x 67 G2
	16202	IN; 58.9 x 12 x 142.5 x RA/S - Cr - 20° - 5 - III	 92-16126	EX; 53.11 x 43 x 9.15; G1; 45°
			 92-16150	IN; 60.11 x 49.3 x 8.4; G1; 30°







5		128							
	G12V 183A		G	1	14618 cm ³	390 kW	530 PS	ε 12,0:1	 142

	99 803 700	Ø cylindra: 128; KH: 80.35; MT: -24; MØ: 92; GL: 125.35; sworze tłokowy: 46x105; Liczba pierieni: 3 RTK, KBB T6 3 MO G6 M 3 CR G3 DSF 4 CR → 80 00195 1 0 ...
		
		



	80 00195 1 0 000	Ø128; 2.00; Zestaw: 1; [T6 G6 MO 3] [M G3 IWU CR 3] [DSF CR 4]
---	-------------------------	--

	89 389 110	N - Mokra tuleja cylindra; skoczony; A=144.5 C=153.8 L=253 H+F=9.92+1, W przypadku silników na gaz, do łodzi, kolejowych i stacjonarnych oraz zasilania paliwami alternatywnymi, stosowa tylko ze specjalnym zestawem pierieni uszczelniających 50 007 890.
	89 389 810	N - Mokra tuleja cylindra; skoczony; A=144.5 C=153.8 L=253 H+F=9.92+1, W przypadku silników na gaz, do łodzi, kolejowych i stacjonarnych oraz zasilania paliwami alternatywnymi, stosowa tylko ze specjalnym zestawem pierieni uszczelniających 50 007 890.









	78 694 604	[para] PASS-L STD Ø 104.000 / 111.000 / 37.810 / 3.474 St/B/G 78 694 614 0,25 / 78 694 624 0,50 / 78 694 634 0,75 / 78 694 644 1,00
	78 897 600	[para] PL STD Ø 90.000 / 95.000 / 31.000 / 2.473 St/B/S; PL STD Ø 90.000 / 95.000 / 31.000 / 2.473 St/B/G1 78 897 605 0,10 / 78 897 610 0,25 / 78 897 620 0,50 / 78 897 630 0,75 / 78 897 640 1,00 , Górna panewka jest oznakowana 'SPUTTER'.
	78 921 600	[para] HL STD Ø 104.000 / 111.000 / 30.500 / 3.472 St/B/G1; HL STD Ø 104.000 / 111.000 / 36.000 / 3.472 St/B/S 78 921 610 0,25 , Dolna panewka jest oznakowana 'SPUTTER'.
	79 443 600	[para] PL STD Ø 90.000 / 95.000 / 31.000 / 2.473 St/B/S, SPUTTER: u góry i u dołu, zastosowanie GAS
	77 250 600	[komplet] HL STD Ø 104.000 / 111.000 / 36.000 / 3.472 St/B/S; HL STD Ø 104.000 / 111.000 / 30.500 / 3.472 St/B/G1; PASS-L STD Ø 104.000 / 111.000 / 37.810 / 3.474 St/B/G 77 250 610 0,25 , Dolna panewka jest oznakowana 'SPUTTER'.
	87 346 690	[komplet] PL-B SEMI Ø 46.000 / 50.600 / 38.700 / St/B
	87 366 600	[komplet] NW-L STD Ø 69.940 / 76.000 / 35.000 / 3.000 St/B; NW-L STD Ø 69.940 / 75.000 / 28.000 / 2.500 St/A

	20 0602 G2801	Długo: 256; rednica otworu lepego duej główki korbowodu: 95; rednica małej główki korbowodu: 46; Szeroko stopy korbowodu: 33; Szeroko łba korbowodu: 39; korbowód trapezowy; krakowany		
	20 0303 44400	bez tulei cylindra		
	16150	EX; 51 x 12 x 142.5 x RA/S - Cr - 45° - 5 - III	 81-16100	IN/EX; 18.03/ x 12 x 67 G2
	16202	IN; 58.9 x 12 x 142.5 x RA/S - Cr - 20° - 5 - III	 92-16126	EX; 53.11 x 43 x 9.15; G1; 45°
			 92-16150	IN; 60.11 x 49.3 x 8.4; G1; 30°

6		130						
	E 3042 D		G	LA	12	22617 cm ³		 142



	41 791 600	Ø cylindra: 130; KH: 80.7; MT: -25.07; MØ: 92.96; GL: 125.7; sworze tłokowy: 46x105; Liczba pierieni: 3 RTK T6 3 CK G6 M 3 CR G3 DSF 4 CK → 80 01232 1 0 ...
		



cont...

	80 01232 1 0 000	Ø130; STD; Zestaw: 1; [T6 G6 IF CK 3] [M G3 CR 3] [DSF CK 4]		
	89 396 120	N - Mokra tuleja cylindra; skoczony; A=144.5 C=153.8 L=253 H+F=9.92+1		
	78 693 600	[para] HL STD Ø 104.000 / 111.000 / 30.500 / 3.472 St/B/G1 78 693 610 0,25 / 78 693 620 0,50 / 78 693 630 0,75 / 78 693 640 1,00		
	78 694 604	[para] PASS-L STD Ø 104.000 / 111.000 / 37.810 / 3.474 St/B/G 78 694 614 0,25 / 78 694 624 0,50 / 78 694 634 0,75 / 78 694 644 1,00		
	78 897 600	[para] PL STD Ø 90.000 / 95.000 / 31.000 / 2.473 St/B/S; PL STD Ø 90.000 / 95.000 / 31.000 / 2.473 St/B/G1 78 897 605 0,10 / 78 897 610 0,25 / 78 897 620 0,50 / 78 897 630 0,75 / 78 897 640 1,00 , Górna panewka jest oznakowana 'SPUTTER'.		
	79 443 600	[para] PL STD Ø 90.000 / 95.000 / 31.000 / 2.473 St/B/S, SPUTTER: u góry i u dołu, zastosowanie GAS		
	87 346 690	[komplet] PL-B SEMI Ø 46.000 / 50.600 / 38.700 / St/B		
	87 366 600	[komplet] NW-L STD Ø 69.940 / 76.000 / 35.000 / 3.000 St/B; NW-L STD Ø 69.940 / 75.000 / 28.000 / 2.500 St/A		
	87 397 604	[komplet] HL STD Ø 104.000 / 111.000 / 30.500 / 3.472 St/B/G1; PASS-L STD Ø 104.000 / 111.000 / 37.810 / 3.474 St/B/G 87 397 614 0,25 / 87 397 624 0,50		
	20 0602 G2801	Długo: 256; rednica otworu lepego duej główki korbowodu: 95; rednica małej główki korbowodu: 46; Szeroko stopy korbowodu: 33; Szeroko łba korbowodu: 39; korbowód trapezowy; krakowany		
	20 0302 28420	bez tulei cylindra		
	20 0802 G2828	- V - G - S - - - - ; element gotowy do montau		
	25311	EX; 51 x 12 x 142.5 x I/S - Cr - 30° - VS - 1 - III		81-25103 EX; 18/ x 12 x 70 G2, Długo rowka olejowego jest różna w zależności od głowicy! 81-25103 ma krótki rowek olejowy. Dopiero po wymontowaniu przewodnicy zaworu można stwierdzić jej wersję. Nie można odróżnić wersji po numerach silnika.
	25310	IN; 58 x 12 x 142.5 x I/S - Cr - 30° - VS - 1 - III		81-25113 EX; 18/ x 12.01 x 70 G2
	92-25018	EX; 53.11 x 43 x 9.5; HWR		81-25101 IN; 18/ x 12.02 x 59.5 G2
	92-25019	IN; 61.11 x 49 x 8.8; HWR		81-2536 IN/EX; 18/ x 12 x 64 G2, W przypadku stosowania gazu używać tylko w obszarze dolotu.



























M

7		130		
	E 3042 L	G LA 12 22617 cm ³ 48V	£ 13,5:1	142

	41 883 600	Ø cylindra: 130; KH: 80.7; MT: -26.2; MØ: 74.4; GL: 125.7; sworze tłokowy: 46x105; Liczba pierścieni: 3 RTK T6 3 CK G6 M 3 CR G3 DSF 4 CK → 80 01232 1 0 ...
	42 176 600	Ø cylindra: 130; KH: 80.7; MT: -32; MØ: 72.3; GL: 125.7; sworze tłokowy: 46x105; Liczba pierścieni: 3 RTK T6 3 CK G6 M 3 CR G3 DSF 4 CK → 80 01232 1 0 ...

	80 01232 1 0 000	Ø130; STD; Zestaw: 1; [T6 G6 IF CK 3] [M G3 CR 3] [DSF CK 4]
	89 396 120	N - Mokra tuleja cylindra; skoczony; A=144.5 C=153.8 L=253 H+F=9.92+1
	78 693 600	[para] HL STD Ø 104.000 / 111.000 / 30.500 / 3.472 St/B/G1 78 693 610 0,25 / 78 693 620 0,50 / 78 693 630 0,75 / 78 693 640 1,00
	78 694 604	[para] PASS-L STD Ø 104.000 / 111.000 / 37.810 / 3.474 St/B/G 78 694 614 0,25 / 78 694 624 0,50 / 78 694 634 0,75 / 78 694 644 1,00
	78 897 600	[para] PL STD Ø 90.000 / 95.000 / 31.000 / 2.473 St/B/S; PL STD Ø 90.000 / 95.000 / 31.000 / 2.473 St/B/G1 78 897 605 0,10 / 78 897 610 0,25 / 78 897 620 0,50 / 78 897 630 0,75 / 78 897 640 1,00 , Górna panewka jest oznakowana 'SPUTTER'.
	79 443 600	[para] PL STD Ø 90.000 / 95.000 / 31.000 / 2.473 St/B/S, SPUTTER: u góry i u dołu, zastosowanie GAS
	87 346 690	[komplet] PL-B SEMI Ø 46.000 / 50.600 / 38.700 / St/B
	87 366 600	[komplet] NW-L STD Ø 69.940 / 76.000 / 35.000 / 3.000 St/B; NW-L STD Ø 69.940 / 75.000 / 28.000 / 2.500 St/A

cont...

87 397 604	[komplet] HL STD Ø 104.000 / 111.000 / 30.500 / 3.472 St/B/G1; PASS-L STD Ø 104.000 / 111.000 / 37.810 / 3.474 St/B/G 87 397 614 0,25 / 87 397 624 0,50		
 20 0602 G2801	Długo: 256; rednica otworu lepego duej główki korbowodu: 95; rednica małej główki korbowodu: 46; Szeroko stopy korbowodu: 33; Szeroko łba korbowodu: 39; korbowód trapezowy; krakowany		
 20 0302 28420	bez tulei cylindra		
 20 0802 G2820	- V - G - S - - - - -; element gotowy do montau, Uywaj do wiecy zapłonowej M14		
 20 0802 G2828	- V - G - S - - - - -; element gotowy do montau		
 20 0802 G2840	- V - G - S - - - - -; element gotowy do montau, Uywaj do wiecy zapłonowej M14		
 25311	EX; 51 x 12 x 142.5 x I/S - Cr - 30° - VS - 1 - III	 81-25103	EX; 18/ x 12 x 70 G2, Długo rowka olejowego jest różna w zalenoci od głowicy! 81-25103 ma krótki rowek olejowy. Dopiero po wymontowaniu przewodnicy zaworu mona stwierdzi jej wersj. Nie mona odróni wersji po numerach silnika.
25310	IN; 58 x 12 x 142.5 x I/S - Cr - 30° - VS - 1 - III	81-25113	EX; 18/ x 12.01 x 70 G2
 92-25018	EX; 53.11 x 43 x 9.5; HWR	81-25101	IN; 18/ x 12.02 x 59.5 G2
 92-25019	IN; 61.11 x 49 x 8.8; HWR	81-2536	IN/EX; 18/ x 12 x 64 G2, W przypadku stosowania gazu uywa tylko w obszarze dolotu.
8	 130		
 E 3042 LH	G LA 12 22617 cm ³		⊘ 13,5:1  142
E 3042 Z	G LA 12 22617 cm ³		⊘ 13,5:1  142
E 3042 ZH	G LA 12 22617 cm ³		⊘ 13,5:1  142
 41 883 600	Ø cylindra: 130; KH: 80.7; MT: -26.2; MØ: 74.4; GL: 125.7; sworze tłokowy: 46x105; Liczba piercieni: 3 RTK T6 3 CK G6 M 3 CR G3 DSF 4 CK → 80 01232 1 0 ...		
 80 01232 1 0 000	Ø130; STD; Zestaw: 1; [T6 G6 IF CK 3] [M G3 CR 3] [DSF CK 4]		
 89 396 120	N - Mokra tuleja cylindra; skoczony; A=144.5 C=153.8 L=253 H+F=9.92+1		
 78 693 600	[para] HL STD Ø 104.000 / 111.000 / 30.500 / 3.472 St/B/G1 78 693 610 0,25 / 78 693 620 0,50 / 78 693 630 0,75 / 78 693 640 1,00		
 78 694 604	[para] PASS-L STD Ø 104.000 / 111.000 / 37.810 / 3.474 St/B/G 78 694 614 0,25 / 78 694 624 0,50 / 78 694 634 0,75 / 78 694 644 1,00		
78 897 600	[para] PL STD Ø 90.000 / 95.000 / 31.000 / 2.473 St/B/S; PL STD Ø 90.000 / 95.000 / 31.000 / 2.473 St/B/G1 78 897 605 0,10 / 78 897 610 0,25 / 78 897 620 0,50 / 78 897 630 0,75 / 78 897 640 1,00 , Górna panewka jest oznakowana 'SPUTTER'.		
79 443 600	[para] PL STD Ø 90.000 / 95.000 / 31.000 / 2.473 St/B/S, SPUTTER: u góry i u dołu, zastosowanie GAS		
87 346 690	[komplet] PL-B SEMI Ø 46.000 / 50.600 / 38.700 / St/B		
87 366 600	[komplet] NW-L STD Ø 69.940 / 76.000 / 35.000 / 3.000 St/B; NW-L STD Ø 69.940 / 75.000 / 28.000 / 2.500 St/A		
87 397 604	[komplet] HL STD Ø 104.000 / 111.000 / 30.500 / 3.472 St/B/G1; PASS-L STD Ø 104.000 / 111.000 / 37.810 / 3.474 St/B/G 87 397 614 0,25 / 87 397 624 0,50		
 20 0602 G2801	Długo: 256; rednica otworu lepego duej główki korbowodu: 95; rednica małej główki korbowodu: 46; Szeroko stopy korbowodu: 33; Szeroko łba korbowodu: 39; korbowód trapezowy; krakowany		
 20 0302 28420	bez tulei cylindra		
 20 0802 G2820	- V - G - S - - - - -; element gotowy do montau, Uywaj do wiecy zapłonowej M14		
 20 0802 G2828	- V - G - S - - - - -; element gotowy do montau		
 20 0802 G2840	- V - G - S - - - - -; element gotowy do montau, Uywaj do wiecy zapłonowej M14		
 25311	EX; 51 x 12 x 142.5 x I/S - Cr - 30° - VS - 1 - III	 81-25103	EX; 18/ x 12 x 70 G2, Długo rowka olejowego jest różna w zalenoci od głowicy! 81-25103 ma krótki rowek olejowy. Dopiero po wymontowaniu przewodnicy zaworu mona stwierdzi jej wersj. Nie mona odróni wersji po numerach silnika.
25310	IN; 58 x 12 x 142.5 x I/S - Cr - 30° - VS - 1 - III	81-25113	EX; 18/ x 12.01 x 70 G2

cont...

	92-25018	EX; 53.11 x 43 x 9.5; HWR	81-25101	IN; 18/ x 12.02 x 59.5 G2
	92-25019	IN; 61.11 x 49 x 8.8; HWR	81-2536	IN/EX; 18/ x 12 x 64 G2, W przypadku stosowania gazu uywa tylko w obszarze dolotu.

9		130			
	E 3066 Z8		G	6	12344 cm ³
					



	78 586 600	[para] HL STD Ø 104.000 / 111.000 / 36.000 / 3.478 St/B/G1 78 586 605 0,10 / 78 586 610 0,25 / 78 586 620 0,50 / 78 586 630 0,75
	78 587 604	[para] PASS-L STD Ø 104.000 / 111.000 / 45.810 / 3.478 St/B/G 78 587 614 0,25 / 78 587 624 0,50
	79 237 600	[para] PL STD Ø 90.000 / 95.000 / 36.200 / 2.478 St/B/G1; PL STD Ø 90.000 / 95.000 / 36.200 / 2.479 St/B/S 79 237 610 0,25 / 79 237 620 0,50 / 79 237 630 0,75 , Górna panewka jest oznakowana 'SPUTTER'.
	79 261 600	[para] AS STD Ø 114.750 / 137.650 // 3.400 St/A 79 261 610 0,40 / 79 261 620 0,80
	79 444 600	[para] PL STD Ø 90.000 / 95.000 / 36.200 / 2.479 St/B/S, SPUTTER: u góry i u dołu, zastosowanie GAS
	77 682 600	[komplet] HL STD Ø 104.000 / 111.000 / 36.000 / 3.478 St/B/G1 77 682 610 0,25 / 77 682 620 0,50
	77 682 700	[komplet] HL STD Ø 104.000 / 111.500 / 36.000 / 3.728 St/B/G1 77 682 710 0,25 , Nadwymiar zewnętrzny + 0,50 mm
	77 812 690	[komplet] PL-B SEMI Ø 50.000 / 54.000 / 38.700 / St/B
	87 501 600	[komplet] NW-L STD Ø 69.940 / 76.000 / 39.000 / 3.000 St/B; NW-L STD Ø 69.940 / 75.000 / 36.000 / 2.500 St/A; NW-L STD Ø 69.940 / 75.000 / 28.000 / 2.500 St/A

	20 0802 G2820	- V - G - S - - - - ; element gotowy do montau, Uywaj do wicy zapłonowej M14
	20 0802 G2828	- V - G - S - - - - ; element gotowy do montau
	20 0802 G2840	- V - G - S - - - - ; element gotowy do montau, Uywaj do wicy zapłonowej M14

	25311	EX; 51 x 12 x 142.5 x I/S - Cr - 30° - VS - 1 - III		81-25103	EX; 18/ x 12 x 70 G2, Długo rowka olejowego jest różna w zależności od głowicy! 81-25103 ma krótki rowek olejowy. Dopiero po wymontowaniu przewodnicy zaworu można stwierdzić jej wersję. Nie można odróżnić wersji po numerach silnika.
--	--------------	---	--	-----------------	---



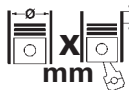



M

	25310	IN; 58 x 12 x 142.5 x I/S - Cr - 30° - VS - 1 - III	81-25113	EX; 18/ x 12.01 x 70 G2
	92-25018	EX; 53.11 x 43 x 9.5; HWR	81-25101	IN; 18/ x 12.02 x 59.5 G2
	92-25019	IN; 61.11 x 49 x 8.8; HWR	81-2536	IN/EX; 18/ x 12 x 64 G2, W przypadku stosowania gazu uywa tylko w obszarze dolotu.
			81-2537	IN/EX; 18.2/ x 12 x 64 G2, W przypadku stosowania gazu uywa tylko w obszarze dolotu.
			81-2538	IN/EX; 18.4/ x 12 x 64 G2, W przypadku stosowania gazu uywa tylko w obszarze dolotu.





		Cyl.	 mm	cm ³		Comp. Ratio ε	kW	PS	Pos
DC 16 Gas		G (LA) 8	127 x 154	15600	4	12:1			2
DSC 12 Gas		G (LA) 6	127 x 154	11716	4	12:1			1
OC 09 Euro 5	101	G (LA) 5	130 x 140	9291	20	12.6	206	280	3
OC 09 Euro 6	104, 105	G (LA) 5	130 x 140	9291	20	12.6	206-250	280-340	5
OC 09 Euro 5	102	G (LA) 5	130 x 140	9291	20	12.6	250	340	4
OC 13 Euro 6	101	G (LA) 6	130 x 160	12742	24	12.6	302	410	6
OC16 071A		G 6	130 x 154	16400	4	12,2:1	333-426	453-580	7

S

1  **127**
DSC 12 Gas G LA 6 11716 cm³ 4V €12:1  154





	40 335 600	Ø cylindra: 127; KH: 84.54; MT: -25.4; MØ: 94; GL: 128.54; sworze tłokowy: 54x106; Liczba piercieni: 3 RTK T15 3.5 CK G6 M 2.385 G3 DSF 3.5 CR → 80 00364 1 0 ... , 80 00364 1 1 ...
	80 00364 1 0 000 80 00364 1 1 000	Ø127; STD; Zestaw: 1; [T15 G6 IW CR 3.5] [M IW 2.385] [DSF CR 3.5] Ø127; STD; Zestaw: 1; [T15 G6 IW CK 3.5] [M G3 IW 2.385] [DSF CR 3.5]
	89 541 110	N - Mokra tuleja cylindra; skoczony; A=139 C=150 L=271.1 H=194.27 Y=8.75
	79 279 600 77 710 600	[para] AS STD Ø 119.050 / 143.700 // 3.430 St/B [komplet] HL STD Ø 108.000 / 112.200 / 34.300 / 2.065 St/B/G 77 710 610 0,25 / 77 710 620 0,50 / 77 710 630 0,75
	77 711 600	[komplet] PL STD Ø 87.000 / 91.230 / 45.000 / 2.085 St/B/G 77 711 610 0,25 / 77 711 620 0,50 / 77 711 630 0,75 , bez otworu olejowego
	77 722 690	[komplet] PL-B SEMI Ø 54.000 / 57.800 / 48.260 / St/B
	105-35654 105-35639	EX; 41 x 10 x 171.5 x RA/S - Cr - 29.5° - VS - 23 - III IN; 44 x 10 x 171.4 x RA/S - Cr - 19.5° - 23 - III
	20 1407 12001	

2  **127**
DC 16 Gas G LA 8 15600 cm³ 4V €12:1  154































	40 335 600	Ø cylindra: 127; KH: 84.54; MT: -25.4; MØ: 94; GL: 128.54; sworze tłokowy: 54x106; Liczba piercieni: 3 RTK T15 3.5 CK G6 M 2.385 G3 DSF 3.5 CR → 80 00364 1 0 ... , 80 00364 1 1 ...
	80 00364 1 0 000 80 00364 1 1 000	Ø127; STD; Zestaw: 1; [T15 G6 IW CR 3.5] [M IW 2.385] [DSF CR 3.5] Ø127; STD; Zestaw: 1; [T15 G6 IW CK 3.5] [M G3 IW 2.385] [DSF CR 3.5]
	79 279 600 77 942 600	[para] AS STD Ø 119.050 / 143.700 // 3.430 St/B [komplet] HL STD Ø 108.000 / 112.200 / 34.300 / 2.065 St/B/G 77 942 620 0,50
	77 943 600	[komplet] PL STD Ø 93.000 / 97.230 / 40.350 / 2.090 St/B/G 77 943 610 0,25 / 77 943 620 0,50
	20 0907 12008	wieniec zbaty; Ø wewnetrzna: 430; Szeroko: 22; Liczba zębów: 158
	20 1007 12100 20 1007 12101	dwigienka zaworowa dwigienka zaworowa

S

3  **130**
OC 09 Euro 5 **101**
 01.2011 → G LA 5 9291 cm³ 20V 206 kW 280 PS €12.6  140
CITYWIDE, INTERLINK, P I, R II







	80 01228 1 0 000	Ø130; STD; Zestaw: 1; [T11 ST DL 2.5] [M G6 CR 1.75] [DSF DC 4]
	89 939 110	N - Mokra tuleja cylindra; skoczony; A=140 C=151 L=270.6 H=194.27
	79 279 600 79 525 600	[para] AS STD Ø 119.050 / 143.700 // 3.430 St/B [para] PL STD Ø 87.000 / 91.230 / 45.000 / 2.085 St/B/G 79 525 610 0,25 / 79 525 620 0,50 , z otworem olejowym
	77 864 600	[komplet] HL STD Ø 108.000 / 112.200 / 34.300 / 2.065 St/B/G 77 864 610 0,25 / 77 864 620 0,50
	20 0507 90000	

cont...

	81-34006	IN/EX; 16.01/ x 10 x 73 G2, dodatkowe napunktowanie na rednicy uszczelnienia trzonka zaworu											
	20 1607 09001	mech.; Tworzywo sztuczne; rednica wirnika pompy: 120											
									 20 1407 09000				
	7.00936.02.0	zawór regulacyjny ciśnienia doładowania; elektryczno-pneumatyczny											
4		130											
	OC 09 Euro 5	102	01.2011 → 05.2019	G	LA	5	9291 cm ³	20V	250 kW	340 PS	ξ12.6	140	
	P I												
	80 01228 1 0 000	Ø130; STD; Zestaw: 1; [T11 ST DL 2.5] [M G6 CR 1.75] [DSF DC 4]											
	89 939 110	N - Mokra tuleja cylindra; skoczony; A=140 C=151 L=270.6 H=194.27											
	79 279 600	[para] AS STD Ø 119.050 / 143.700 // 3.430 St/B											
	79 525 600	[para] PL STD Ø 87.000 / 91.230 / 45.000 / 2.085 St/B/G											
	77 864 600	[komplet] HL STD Ø 108.000 / 112.200 / 34.300 / 2.065 St/B/G											
	77 864 610 0,25 / 77 864 620 0,50	z otworem olejowym											
	20 0507 90000												
	20 0907 16000	koło zamachowe; Ø zewntrzna: 257; Ø wewntrzna: 468; Szeroko: 85; Liczba zębów: 158											
	81-34006	IN/EX; 16.01/ x 10 x 73 G2, dodatkowe napunktowanie na rednicy uszczelnienia trzonka zaworu											
											92-34009	EX; 44.08 x 35.5 x 7.8; G6; 30°	
											92-34008	IN; 46.08 x 41 x 7.9; G3; 20°	
	20 1607 09001	mech.; Tworzywo sztuczne; rednica wirnika pompy: 120										20 1407 09000	
											20 1407 09004		
	20 1907 14000	Długo: 394; Szeroko: 119; Wysoko: 52; Masa: 5.3 g											
	7.00936.02.0	zawór regulacyjny ciśnienia doładowania; elektryczno-pneumatyczny											
5		130											
	OC 09 Euro 6	104, 105	01.2011 →	G	LA	5	9291 cm ³	20V	206-250 kW	280-340 PS	ξ12.6	140	
	CITYWIDE, G II, L, P II, R II												
	80 01228 1 0 000	Ø130; STD; Zestaw: 1; [T11 ST DL 2.5] [M G6 CR 1.75] [DSF DC 4]											
	89 939 110	N - Mokra tuleja cylindra; skoczony; A=140 C=151 L=270.6 H=194.27											
	79 279 600	[para] AS STD Ø 119.050 / 143.700 // 3.430 St/B											
	79 525 600	[para] PL STD Ø 87.000 / 91.230 / 45.000 / 2.085 St/B/G											
	77 864 600	[komplet] HL STD Ø 108.000 / 112.200 / 34.300 / 2.065 St/B/G											
	77 864 610 0,25 / 77 864 620 0,50	z otworem olejowym											
	20 0507 90000												
	81-34006	IN/EX; 16.01/ x 10 x 73 G2, dodatkowe napunktowanie na rednicy uszczelnienia trzonka zaworu											
												92-34009	EX; 44.08 x 35.5 x 7.8; G6; 30°
												92-34008	IN; 46.08 x 41 x 7.9; G3; 20°
	20 1607 09001	mech.; Tworzywo sztuczne; rednica wirnika pompy: 120										20 1407 09000	
												20 1407 09004	

cont...

S

	7.12441.12.0								
	7.05717.06.0	zawór recyrkulacji powietrza; elektryczny							
6		130							
	OC 13 Euro 6	101							
	G II, P II, R II, S	12.2017→	G	LA	6	12742 cm ³	24V	302 kW	410 PS
								€ 12.6	 160
	80 01228 1 0 000	Ø130; STD; Zestaw: 1; [T11 ST DL 2.5] [M G6 CR 1.75] [DSF DC 4]							
	89 939 110	N - Mokra tuleja cylindra; skoczony; A=140 C=151 L=270.6 H=194.27							
	89 935 110	N - Mokra tuleja cylindra; skoczony; A=140 C=151 L=271.17 H=194.27 X=8.85							
	79 279 600	[para] AS STD Ø 119.050 / 143.700 // 3.430 St/B							
	77 710 600	[komplet] HL STD Ø 108.000 / 112.200 / 34.300 / 2.065 St/B/G 77 710 610 0,25 / 77 710 620 0,50 / 77 710 630 0,75							
	77 738 600	[komplet] NW-L STD Ø 84.950 / 89.000 / 35.000 / 2.000 St/B							
	77 971 600	[komplet] PL STD Ø 93.000 / 97.230 / 43.000 / 2.085 St/B/G 77 971 610 0,25 / 77 971 620 0,50							
	20 0607 DC130	Długo: 255; rednica otworu lepego duej główki korbowodu: 97.2; rednica małej główki korbowodu: 58; Szeroko stopy korbowodu: 53.7; Szeroko łba korbowodu: 47; Korbowód stopniowy; piłowany							
	20 0507 13000								
	20 0907 DC130	koło zamachowe; Ø zewnttrzna: 470; Ø wewnttrzna: 257; Szeroko: 84							
	81-34006	IN/EX; 16.01/ x 10 x 73 G2, dodatkowe napunktowanie na rednicy uszczelnienia trzonka zaworu		92-34009	EX; 44.08 x 35.5 x 7.8; G6; 30°				
				92-34008	IN; 46.08 x 41 x 7.9; G3; 20°				
	20 1007 12008								
	20 1607 13001	mech.; Tworzywo sztuczne; rednica wirnika pompy: 120		20 1407 13000					
				20 1407 13001					
	7.12441.12.0								
7		130							
	OC16 071A		G	6	16400 cm ³	4V	333-426 kW	453-580 PS	€ 12,2:1  154
	80 01228 1 0 000	Ø130; STD; Zestaw: 1; [T11 ST DL 2.5] [M G6 CR 1.75] [DSF DC 4]							
	89 935 110	N - Mokra tuleja cylindra; skoczony; A=140 C=151 L=271.17 H=194.27 X=8.85							
	81-34005	IN/EX; 16.01/ x 10 x 73 G2, dodatkowe napunktowanie na rednicy uszczelnienia trzonka zaworu							
	81-34006	IN/EX; 16.01/ x 10 x 73 G2, dodatkowe napunktowanie na rednicy uszczelnienia trzonka zaworu							
	20 1007 16002								
	20 1007 16003	z lewej							
	20 1407 16002								
	20 1907 14003	Długo: 400; Szeroko: 160; Wysoko: 52							

LISTA PORÓWNAWCZA

REF-No.	ITEM No.	Pos (→ )
DEUTZ		
0116 8818	KK-10H	
0292 9724	20050510156	1 (→ 23)
0293 1396		
0293 1430		
0293 1444		
0293 1446		
0293 1466		
0420 0194	20010510150	1 (→ 23), 2 (→ 23)
0422 0142	22210	1 (→ 23), 2 (→ 23)
0422 0708	81-22111	1 (→ 23), 2 (→ 23)
0422 1553	89 443 110	1 (→ 23), 2 (→ 23)
0422 1744	20010510150	1 (→ 23), 2 (→ 23)
0422 5353	22321	1 (→ 23), 2 (→ 23)
0422 6412	22210	1 (→ 23), 2 (→ 23)
0422 6518	89 443 110	1 (→ 23), 2 (→ 23)
0422 6562	22321	1 (→ 23), 2 (→ 23)
0422 7079	89 443 110	1 (→ 23), 2 (→ 23)
0425 7888	7.01268.03.0	
0426 6334	94 728 600	1 (→ 23), 2 (→ 23)
0426 7453	22321	1 (→ 23), 2 (→ 23)
0426 7455	22210	1 (→ 23), 2 (→ 23)
0426 8370	22321	1 (→ 23), 2 (→ 23)
0426 8373	22210	1 (→ 23), 2 (→ 23)
1216 4698	MK-9H	
9136/00	94 728 600	1 (→ 23), 2 (→ 23)
DOOSAN		
150117-00026	89 935 110	
451144	79 279 600	
502760	80 00364 1 0 000	
509122	77 710 610	
509122	77 864 610	
509123	77 710 620	
509123	77 864 620	
512037	105-35639	
512045	89 541 110	
514123	77 710 600	
516496	77 864 600	
ENERGIE 2G		
31010-00077	79 261 600	10 (→ 34), 11 (→ 35), 12 (→ 36)
31010-00093	200602G2801	3 (→ 28), 4 (→ 29), 6 (→ 30), 7 (→ 31), 9 (→ 33)
31010-00095	200602G2876	1 (→ 28), 5 (→ 29), 10 (→ 34), 11 (→ 35), 12 (→ 36)
31010-00421	20030228661	1 (→ 28), 5 (→ 29), 10 (→ 34), 11 (→ 35), 12 (→ 36)
31010-00422	20140344400	3 (→ 28), 9 (→ 33)
31010-00730	20030228420	4 (→ 29), 6 (→ 30), 7 (→ 31), 8 (→ 32)
31010-00901-AT	20050228760	1 (→ 28), 5 (→ 29), 10 (→ 34), 11 (→ 35), 12 (→ 36)
31010-00934	201002G2866	1 (→ 28), 5 (→ 29), 10 (→ 34), 11 (→ 35), 12 (→ 36)
31010-10306	41 498 600	11 (→ 35), 12 (→ 36)
31030-00125	94 943 600	6 (→ 30)
31030-00157	41 000 600	7 (→ 31), 8 (→ 32), 9 (→ 33)
61014-03060	77 682 600	10 (→ 34), 11 (→ 35), 12 (→ 36)
71000-00014	79 444 600	1 (→ 28), 5 (→ 29), 10 (→ 34), 11 (→ 35), 12 (→ 36)
IVECO		
2996836	42 352 600	1 (→ 39)
LIEBHERR		
10116008	89 958 110	2 (→ 41), 3 (→ 41)
10119587		
10125680	92-23002	1 (→ 41), 2 (→ 41), 3 (→ 41)
10128065	81-23001	1 (→ 41), 2 (→ 41), 3 (→ 41)
10129346	81-23002	4 (→ 41), 5 (→ 41)
10129365	105-35671	5 (→ 41)
10131700	105-35670	5 (→ 41)
10131894	105-46000	3 (→ 41)
10131985	92-23001	1 (→ 41), 2 (→ 41), 3 (→ 41)
10133117	89 959 110	4 (→ 41), 5 (→ 41)
10136751	105-46001	3 (→ 41)

LISTA PORÓWNAWCZA

REF-No.	ITEM No.	Pos (→ )
LIEBHERR		
12453900	89 959 110	4 (→ 41), 5 (→ 41)
740167760	78 693 600	
MAN		
04.10160-9164	20140208260	3 (→ 44), 4 (→ 44), 5 (→ 45)
04.10160-9164	20140208340	1 (→ 43), 2 (→ 43), 6 (→ 45)
04.90300-9025	20140208260	3 (→ 44), 4 (→ 44), 5 (→ 45)
04.90300-9025	20140208340	1 (→ 43), 2 (→ 43), 6 (→ 45)
06.01284-5113	20140208260	3 (→ 44), 4 (→ 44), 5 (→ 45)
06.01284-5113	20140208340	1 (→ 43), 2 (→ 43), 6 (→ 45)
06.02094-4511	20140220660	7 (→ 46), 9 (→ 47)
06.02094-4511	20140226760	9 (→ 47)
06.02094-4511	20140226761	8 (→ 46), 9 (→ 47)
06.02099-0380	20140220660	7 (→ 46), 9 (→ 47)
06.02099-0380	20140226760	9 (→ 47)
06.02099-0380	20140226761	8 (→ 46), 9 (→ 47)
06.03216-6204	20140220660	7 (→ 46), 9 (→ 47)
06.03216-6204	20140226760	9 (→ 47)
06.03216-6204	20140226761	8 (→ 46), 9 (→ 47)
06.03216-8204	20140220660	7 (→ 46), 9 (→ 47)
06.03216-8204	20140226760	9 (→ 47)
06.03216-8204	20140226761	8 (→ 46), 9 (→ 47)
06.11271-6405	20140208260	3 (→ 44), 4 (→ 44), 5 (→ 45)
06.11271-6405	20140208340	1 (→ 43), 2 (→ 43), 6 (→ 45)
06.15015-0411	20140208260	3 (→ 44), 4 (→ 44), 5 (→ 45)
06.15015-0411	20140208340	1 (→ 43), 2 (→ 43), 6 (→ 45)
06.16049-0024	20140208260	3 (→ 44), 4 (→ 44), 5 (→ 45)
06.16049-0024	20140208340	1 (→ 43), 2 (→ 43), 6 (→ 45)
06.21641-0604	20140220660	7 (→ 46), 9 (→ 47)
06.21641-0604	20140226760	9 (→ 47)
06.21641-0604	20140226761	8 (→ 46), 9 (→ 47)
06.21649-0003	20140220660	7 (→ 46), 9 (→ 47)
06.21649-0003	20140226760	9 (→ 47)
06.21649-0003	20140226761	8 (→ 46), 9 (→ 47)
06.56331-0251	20140220660	7 (→ 46), 9 (→ 47)
06.56331-0251	20140226760	9 (→ 47)
06.56331-0251	20140226761	8 (→ 46), 9 (→ 47)
06.56333-4245	20140208260	3 (→ 44), 4 (→ 44), 5 (→ 45)
06.56333-4245	20140208340	1 (→ 43), 2 (→ 43), 6 (→ 45)
06.56936-1150	20140220660	7 (→ 46), 9 (→ 47)
06.56936-1150	20140226760	9 (→ 47)
06.56936-1150	20140226761	8 (→ 46), 9 (→ 47)
06.56936-1328	20140226760	9 (→ 47)
06.56936-1328	20140226761	8 (→ 46), 9 (→ 47)
50.02500-6002	41 260 600	14 (→ 51), 19 (→ 57)
50.02500-6008	41 498 600	15 (→ 52)
50.03100-6001	200802G2840	11 (→ 48), 12 (→ 49) ... 23 (→ 61), 24 (→ 63)
50.04101-0002	25324	11 (→ 48), 12 (→ 49) ... 23 (→ 61), 24 (→ 63)
51.01100-6153	20030225380	13 (→ 50)
51.01100-6164	20030228420	11 (→ 48), 12 (→ 49) ... 23 (→ 61), 24 (→ 63)
51.01100-6283		
51.01101-6802	20030225380	13 (→ 50)
51.01101-6906	20030228420	11 (→ 48), 12 (→ 49) ... 23 (→ 61), 24 (→ 63)
51.01101-6960		
51.01102-6035	20030225380	13 (→ 50)
51.01102-6039	20030228420	11 (→ 48), 12 (→ 49) ... 23 (→ 61), 24 (→ 63)
51.01102-6056		
51.01102-6232	20030228661	14 (→ 51), 15 (→ 52) ... 19 (→ 57), 20 (→ 58)
51.01102-6235	20030228420	11 (→ 48), 12 (→ 49) ... 23 (→ 61), 24 (→ 63)
51.01102-6270	20030228661	14 (→ 51), 15 (→ 52) ... 19 (→ 57), 20 (→ 58)
51.01102-6289		
51.01102-6333		
51.01102-6334		
51.01102-6398		
51.01110-0711	78 586 600	8 (→ 46), 9 (→ 47) ... 18 (→ 56), 19 (→ 57)
51.01110-0712		
51.01110-0729	78 586 605	8 (→ 46), 9 (→ 47) ... 18 (→ 56), 19 (→ 57)
51.01110-0730		

LISTA PORÓWNAWCZA

REF-No.	ITEM No.	Pos (→ )
MAN		
51.01110-0747	78 586 610	8 (→ 46), 9 (→ 47) ... 18 (→ 56), 19 (→ 57)
51.01110-0748		
51.01110-0749	78 586 620	8 (→ 46), 9 (→ 47) ... 18 (→ 56), 19 (→ 57)
51.01110-0750		
51.01110-0751	78 586 630	8 (→ 46), 9 (→ 47) ... 18 (→ 56), 19 (→ 57)
51.01110-0752		
51.01110-6372	78 586 600	8 (→ 46), 9 (→ 47) ... 18 (→ 56), 19 (→ 57)
51.01110-6373	78 586 605	8 (→ 46), 9 (→ 47) ... 18 (→ 56), 19 (→ 57)
51.01110-6374	78 586 610	8 (→ 46), 9 (→ 47) ... 18 (→ 56), 19 (→ 57)
51.01110-6375	78 586 620	8 (→ 46), 9 (→ 47) ... 18 (→ 56), 19 (→ 57)
51.01110-6376	78 586 630	8 (→ 46), 9 (→ 47) ... 18 (→ 56), 19 (→ 57)
51.01110-6407	78 586 600	8 (→ 46), 9 (→ 47) ... 18 (→ 56), 19 (→ 57)
51.01110-6408	78 586 605	8 (→ 46), 9 (→ 47) ... 18 (→ 56), 19 (→ 57)
51.01110-6409	78 586 610	8 (→ 46), 9 (→ 47) ... 18 (→ 56), 19 (→ 57)
51.01110-6410	78 586 620	8 (→ 46), 9 (→ 47) ... 18 (→ 56), 19 (→ 57)
51.01110-6411	78 586 630	8 (→ 46), 9 (→ 47) ... 18 (→ 56), 19 (→ 57)
51.01110-6413	78 586 600	8 (→ 46), 9 (→ 47) ... 18 (→ 56), 19 (→ 57)
51.01110-6415	78 586 605	8 (→ 46), 9 (→ 47) ... 18 (→ 56), 19 (→ 57)
51.01110-6416	78 586 610	8 (→ 46), 9 (→ 47) ... 18 (→ 56), 19 (→ 57)
51.01110-6417	78 586 620	8 (→ 46), 9 (→ 47) ... 18 (→ 56), 19 (→ 57)
51.01110-6418	78 586 630	8 (→ 46), 9 (→ 47) ... 18 (→ 56), 19 (→ 57)
51.01110-6503	77 743 600	1 (→ 43), 2 (→ 43), 3 (→ 44)
51.01110-6503	77 744 600	4 (→ 44), 5 (→ 45)
51.01110-6503	79 234 600	1 (→ 43), 2 (→ 43) ... 6 (→ 45), 7 (→ 46)
51.01111-0719	78 587 604	
51.01111-0720		
51.01111-0747	78 587 614	
51.01111-0748		
51.01111-0749	78 587 624	
51.01111-0750		
51.01111-0773	78 694 614	11 (→ 48), 12 (→ 49) ... 23 (→ 61), 24 (→ 63)
51.01111-0774		
51.01111-0777	78 694 634	11 (→ 48), 12 (→ 49) ... 23 (→ 61), 24 (→ 63)
51.01111-0778		
51.01111-0779	78 694 644	11 (→ 48), 12 (→ 49) ... 23 (→ 61), 24 (→ 63)
51.01111-0780		
51.01111-6019	78 587 604	
51.01111-6372		
51.01111-6374	78 587 614	
51.01111-6375	78 587 624	
51.01111-6380	78 694 614	11 (→ 48), 12 (→ 49) ... 23 (→ 61), 24 (→ 63)
51.01111-6395		
51.01111-6397	78 694 634	11 (→ 48), 12 (→ 49) ... 23 (→ 61), 24 (→ 63)
51.01111-6398	78 694 644	11 (→ 48), 12 (→ 49) ... 23 (→ 61), 24 (→ 63)
51.01111-6407	78 587 604	
51.01111-6409	78 587 614	
51.01111-6410	78 587 624	
51.01111-6413	78 587 604	
51.01111-6416	78 587 614	
51.01111-6417	78 587 624	
51.01111-6421	78 694 614	11 (→ 48), 12 (→ 49) ... 23 (→ 61), 24 (→ 63)
51.01111-6423	78 694 634	11 (→ 48), 12 (→ 49) ... 23 (→ 61), 24 (→ 63)
51.01111-6424	78 694 644	11 (→ 48), 12 (→ 49) ... 23 (→ 61), 24 (→ 63)
51.01111-6431	78 694 614	11 (→ 48), 12 (→ 49) ... 23 (→ 61), 24 (→ 63)
51.01111-6433	78 694 634	11 (→ 48), 12 (→ 49) ... 23 (→ 61), 24 (→ 63)
51.01111-6434	78 694 644	11 (→ 48), 12 (→ 49) ... 23 (→ 61), 24 (→ 63)
51.01111-6467	78 694 614	11 (→ 48), 12 (→ 49) ... 23 (→ 61), 24 (→ 63)
51.01111-6524		
51.01111-6526	78 694 634	11 (→ 48), 12 (→ 49) ... 23 (→ 61), 24 (→ 63)
51.01111-6527	78 694 644	11 (→ 48), 12 (→ 49) ... 23 (→ 61), 24 (→ 63)
51.01111-6536	78 694 614	11 (→ 48), 12 (→ 49) ... 23 (→ 61), 24 (→ 63)
51.01111-6538	78 694 634	11 (→ 48), 12 (→ 49) ... 23 (→ 61), 24 (→ 63)
51.01111-6539	78 694 644	11 (→ 48), 12 (→ 49) ... 23 (→ 61), 24 (→ 63)
51.01113-6001	79 234 600	1 (→ 43), 2 (→ 43) ... 6 (→ 45), 7 (→ 46)
51.01113-6010	78 586 600	8 (→ 46), 9 (→ 47) ... 18 (→ 56), 19 (→ 57)
51.01113-6012	78 586 605	8 (→ 46), 9 (→ 47) ... 18 (→ 56), 19 (→ 57)
51.01113-6013	78 586 610	8 (→ 46), 9 (→ 47) ... 18 (→ 56), 19 (→ 57)
51.01113-6014	78 586 620	8 (→ 46), 9 (→ 47) ... 18 (→ 56), 19 (→ 57)

LISTA PORÓWNAWCZA

REF-No.	ITEM No.	Pos (→ )
MAN		
51.01113-6015	78 586 630	8 (→ 46), 9 (→ 47) ... 18 (→ 56), 19 (→ 57)
51.01113-6019	79 234 610	1 (→ 43), 2 (→ 43) ... 6 (→ 45), 7 (→ 46)
51.01113-6029	79 234 600	1 (→ 43), 2 (→ 43) ... 6 (→ 45), 7 (→ 46)
51.01113-6031	79 234 610	1 (→ 43), 2 (→ 43) ... 6 (→ 45), 7 (→ 46)
51.01113-6032	79 234 620	1 (→ 43), 2 (→ 43) ... 6 (→ 45), 7 (→ 46)
51.01113-6035	78 586 600	8 (→ 46), 9 (→ 47) ... 18 (→ 56), 19 (→ 57)
51.01113-6037	78 586 605	8 (→ 46), 9 (→ 47) ... 18 (→ 56), 19 (→ 57)
51.01113-6038	78 586 610	8 (→ 46), 9 (→ 47) ... 18 (→ 56), 19 (→ 57)
51.01113-6039	78 586 620	8 (→ 46), 9 (→ 47) ... 18 (→ 56), 19 (→ 57)
51.01113-6042	79 234 600	1 (→ 43), 2 (→ 43) ... 6 (→ 45), 7 (→ 46)
51.01113-6044	78 586 600	8 (→ 46), 9 (→ 47) ... 18 (→ 56), 19 (→ 57)
51.01113-6045	78 586 605	8 (→ 46), 9 (→ 47) ... 18 (→ 56), 19 (→ 57)
51.01113-6046	78 586 610	8 (→ 46), 9 (→ 47) ... 18 (→ 56), 19 (→ 57)
51.01113-6051	79 234 610	1 (→ 43), 2 (→ 43) ... 6 (→ 45), 7 (→ 46)
51.01113-6052	79 234 620	1 (→ 43), 2 (→ 43) ... 6 (→ 45), 7 (→ 46)
51.01113-6066	79 341 600	20 (→ 58)
51.01113-6072	78 586 600	8 (→ 46), 9 (→ 47) ... 18 (→ 56), 19 (→ 57)
51.01113-6073		
51.01113-6074	78 586 605	8 (→ 46), 9 (→ 47) ... 18 (→ 56), 19 (→ 57)
51.01113-6075	78 586 610	8 (→ 46), 9 (→ 47) ... 18 (→ 56), 19 (→ 57)
51.01113-6076	78 586 620	8 (→ 46), 9 (→ 47) ... 18 (→ 56), 19 (→ 57)
51.01113-6077	78 586 630	8 (→ 46), 9 (→ 47) ... 18 (→ 56), 19 (→ 57)
51.01113-6081	78 586 600	8 (→ 46), 9 (→ 47) ... 18 (→ 56), 19 (→ 57)
51.01113-6082		
51.01113-6090	78 586 605	8 (→ 46), 9 (→ 47) ... 18 (→ 56), 19 (→ 57)
51.01113-6091	78 586 610	8 (→ 46), 9 (→ 47) ... 18 (→ 56), 19 (→ 57)
51.01113-6092	78 586 620	8 (→ 46), 9 (→ 47) ... 18 (→ 56), 19 (→ 57)
51.01113-6127	78 586 605	8 (→ 46), 9 (→ 47) ... 18 (→ 56), 19 (→ 57)
51.01113-6128	78 586 610	8 (→ 46), 9 (→ 47) ... 18 (→ 56), 19 (→ 57)
51.01113-6129	78 586 620	8 (→ 46), 9 (→ 47) ... 18 (→ 56), 19 (→ 57)
51.01113-6173	78 586 600	8 (→ 46), 9 (→ 47) ... 18 (→ 56), 19 (→ 57)
51.01113-6175		
51.01113-6198		
51.01113-6199		
51.01114-4048	79 235 600	6 (→ 45), 7 (→ 46)
51.01114-6010	78 587 604	
51.01114-6013	78 587 614	
51.01114-6014	78 587 624	
51.01114-6019	78 587 604	
51.01114-6021	78 587 614	
51.01114-6022	78 587 624	
51.01114-6049	77 586 600	6 (→ 45)
51.01114-6049	77 587 600	7 (→ 46)
51.01114-6049	79 235 600	6 (→ 45), 7 (→ 46)
51.01114-6058	79 235 610	6 (→ 45), 7 (→ 46)
51.01114-6072	79 235 600	6 (→ 45), 7 (→ 46)
51.01114-6074	79 235 610	6 (→ 45), 7 (→ 46)
51.01114-6078	79 235 600	6 (→ 45), 7 (→ 46)
51.01114-6080	79 235 610	6 (→ 45), 7 (→ 46)
51.01114-6087	78 694 614	11 (→ 48), 12 (→ 49) ... 23 (→ 61), 24 (→ 63)
51.01114-6089	78 694 634	11 (→ 48), 12 (→ 49) ... 23 (→ 61), 24 (→ 63)
51.01114-6090	78 694 644	11 (→ 48), 12 (→ 49) ... 23 (→ 61), 24 (→ 63)
51.01114-6091	79 235 600	6 (→ 45), 7 (→ 46)
51.01114-6094	79 235 610	6 (→ 45), 7 (→ 46)
51.01114-6110	79 261 600	8 (→ 46), 9 (→ 47) ... 19 (→ 57), 20 (→ 58)
51.01114-6111	79 261 610	8 (→ 46), 9 (→ 47) ... 19 (→ 57), 20 (→ 58)
51.01114-6112	79 261 620	8 (→ 46), 9 (→ 47) ... 19 (→ 57), 20 (→ 58)
51.01114-6116	79 261 600	8 (→ 46), 9 (→ 47) ... 19 (→ 57), 20 (→ 58)
51.01201-0305	89 092 110	
51.01201-0318	89 470 110	1 (→ 43), 3 (→ 44) ... 6 (→ 45), 7 (→ 46)
51.01201-0321	89 453 110	1 (→ 43), 4 (→ 44), 5 (→ 45), 6 (→ 45), 7 (→ 46)
51.01201-0378	89 470 110	1 (→ 43), 3 (→ 44) ... 6 (→ 45), 7 (→ 46)
51.01201-0379	89 453 110	1 (→ 43), 4 (→ 44), 5 (→ 45), 6 (→ 45), 7 (→ 46)
51.01201-0386	89 470 110	1 (→ 43), 3 (→ 44) ... 6 (→ 45), 7 (→ 46)
51.01201-0400	89 453 110	1 (→ 43), 4 (→ 44), 5 (→ 45), 6 (→ 45), 7 (→ 46)
51.01201-0456	89 856 111	8 (→ 46), 9 (→ 47)
51.01201-0459		
51.01201-0465	89 955 110	25 (→ 64), 26 (→ 64), 28 (→ 65), 29 (→ 65)

LISTA PORÓWNAWCZA

REF-No.	ITEM No.	Pos (→ )
MAN		
51.01201-0467	89 092 110	
51.01201-0477	89 856 111	8 (→ 46), 9 (→ 47)
51.02100-6018	20050228760	14 (→ 51), 15 (→ 52) ... 19 (→ 57), 20 (→ 58)
51.02100-6022	20050208362	4 (→ 44), 5 (→ 45)
51.02100-6028	20050208343	1 (→ 43), 2 (→ 43), 3 (→ 44)
51.02100-6058	20050228760	14 (→ 51), 15 (→ 52) ... 19 (→ 57), 20 (→ 58)
51.02100-6068	20050208362	4 (→ 44), 5 (→ 45)
51.02100-9022		
51.02100-9028	20050208343	1 (→ 43), 2 (→ 43), 3 (→ 44)
51.02101-0536	20050228760	14 (→ 51), 15 (→ 52) ... 19 (→ 57), 20 (→ 58)
51.02101-0573		
51.02101-0581		
51.02101-0608	20050208360	4 (→ 44), 5 (→ 45)
51.02101-0632	20050226760	8 (→ 46), 9 (→ 47)
51.02101-0640	20050208343	1 (→ 43), 2 (→ 43), 3 (→ 44)
51.02101-0801	20050226760	8 (→ 46), 9 (→ 47)
51.02101-6021	20050228760	14 (→ 51), 15 (→ 52) ... 19 (→ 57), 20 (→ 58)
51.02101-6022	20050208360	4 (→ 44), 5 (→ 45)
51.02101-6038	20050228760	14 (→ 51), 15 (→ 52) ... 19 (→ 57), 20 (→ 58)
51.02101-6044		
51.02101-6050	20050208360	4 (→ 44), 5 (→ 45)
51.02101-6056		
51.02101-6082	20050228760	14 (→ 51), 15 (→ 52) ... 19 (→ 57), 20 (→ 58)
51.02101-6090	20050208360	4 (→ 44), 5 (→ 45)
51.02101-6101	20050228760	14 (→ 51), 15 (→ 52) ... 19 (→ 57), 20 (→ 58)
51.02101-7706		
51.02400-6011	200602G2876	14 (→ 51), 15 (→ 52) ... 19 (→ 57), 20 (→ 58)
51.02400-6012		
51.02400-6015	20060208261	6 (→ 45), 7 (→ 46)
51.02400-6034	200602G2801	11 (→ 48), 12 (→ 49) ... 23 (→ 61), 24 (→ 63)
51.02400-6049	200602G2876	14 (→ 51), 15 (→ 52) ... 19 (→ 57), 20 (→ 58)
51.02400-6050		
51.02400-6051		
51.02400-6121	20060226760	8 (→ 46), 9 (→ 47)
51.02400-6151		
51.02400-6156	20060226761	8 (→ 46), 9 (→ 47)
51.02400-6176		
51.02401-6221	20060208261	6 (→ 45), 7 (→ 46)
51.02401-6242	200602G2876	14 (→ 51), 15 (→ 52) ... 19 (→ 57), 20 (→ 58)
51.02401-6243		
51.02401-6267	20060208261	6 (→ 45), 7 (→ 46)
51.02401-6277		
51.02401-6288	200602G2876	14 (→ 51), 15 (→ 52) ... 19 (→ 57), 20 (→ 58)
51.02410-0470	78 897 630	11 (→ 48), 12 (→ 49) ... 23 (→ 61), 24 (→ 63)
51.02410-0491	79 236 600	6 (→ 45), 7 (→ 46)
51.02410-0638	79 237 610	14 (→ 51), 15 (→ 52) ... 19 (→ 57), 20 (→ 58)
51.02410-6481	79 236 600	6 (→ 45), 7 (→ 46)
51.02410-6483	79 236 610	6 (→ 45), 7 (→ 46)
51.02410-6484	79 236 620	6 (→ 45), 7 (→ 46)
51.02410-6488	78 897 600	11 (→ 48), 12 (→ 49) ... 23 (→ 61), 24 (→ 63)
51.02410-6491	79 236 600	6 (→ 45), 7 (→ 46)
51.02410-6493	79 236 610	6 (→ 45), 7 (→ 46)
51.02410-6494	79 236 620	6 (→ 45), 7 (→ 46)
51.02410-6509	79 236 600	6 (→ 45), 7 (→ 46)
51.02410-6510		
51.02410-6516	78 897 610	11 (→ 48), 12 (→ 49) ... 23 (→ 61), 24 (→ 63)
51.02410-6517	78 897 620	11 (→ 48), 12 (→ 49) ... 23 (→ 61), 24 (→ 63)
51.02410-6518	78 897 630	11 (→ 48), 12 (→ 49) ... 23 (→ 61), 24 (→ 63)
51.02410-6519	78 897 640	11 (→ 48), 12 (→ 49) ... 23 (→ 61), 24 (→ 63)
51.02410-6521	79 236 610	6 (→ 45), 7 (→ 46)
51.02410-6522	79 236 620	6 (→ 45), 7 (→ 46)
51.02410-6526	79 236 610	6 (→ 45), 7 (→ 46)
51.02410-6527	79 236 620	6 (→ 45), 7 (→ 46)
51.02410-6551	78 897 600	11 (→ 48), 12 (→ 49) ... 23 (→ 61), 24 (→ 63)
51.02410-6553	78 897 610	11 (→ 48), 12 (→ 49) ... 23 (→ 61), 24 (→ 63)
51.02410-6554	78 897 620	11 (→ 48), 12 (→ 49) ... 23 (→ 61), 24 (→ 63)
51.02410-6555	78 897 630	11 (→ 48), 12 (→ 49) ... 23 (→ 61), 24 (→ 63)
51.02410-6556	78 897 640	11 (→ 48), 12 (→ 49) ... 23 (→ 61), 24 (→ 63)
51.02410-6606	79 237 600	14 (→ 51), 15 (→ 52) ... 19 (→ 57), 20 (→ 58)

LISTA PORÓWNAWCZA

REF-No.	ITEM No.	Pos (→ )
MAN		
51.02410-6622	79 237 610	14 (→ 51), 15 (→ 52) ... 19 (→ 57), 20 (→ 58)
51.02410-6632	79 237 600	14 (→ 51), 15 (→ 52) ... 19 (→ 57), 20 (→ 58)
51.02410-6634	79 237 610	14 (→ 51), 15 (→ 52) ... 19 (→ 57), 20 (→ 58)
51.02410-6635	79 237 620	14 (→ 51), 15 (→ 52) ... 19 (→ 57), 20 (→ 58)
51.02410-6636	79 237 630	14 (→ 51), 15 (→ 52) ... 19 (→ 57), 20 (→ 58)
51.02410-6638	79 333 600	1 (→ 43), 2 (→ 43), 3 (→ 44), 4 (→ 44), 5 (→ 45)
51.02410-6639		
51.02410-6655	79 236 600	6 (→ 45), 7 (→ 46)
51.02410-6658	79 237 600	14 (→ 51), 15 (→ 52) ... 19 (→ 57), 20 (→ 58)
51.02410-6662	77 588 600	6 (→ 45)
51.02410-6662	77 589 600	7 (→ 46)
51.02410-6662	79 236 600	6 (→ 45), 7 (→ 46)
51.02410-6668	79 333 610	1 (→ 43), 2 (→ 43), 3 (→ 44), 4 (→ 44), 5 (→ 45)
51.02410-6672	79 237 600	14 (→ 51), 15 (→ 52) ... 19 (→ 57), 20 (→ 58)
51.02410-6674	79 405 600	8 (→ 46), 9 (→ 47)
51.02410-6683	79 237 610	14 (→ 51), 15 (→ 52) ... 19 (→ 57), 20 (→ 58)
51.02410-6684	79 237 620	14 (→ 51), 15 (→ 52) ... 19 (→ 57), 20 (→ 58)
51.02410-6692	37 280 600	8 (→ 46), 9 (→ 47)
51.02410-6692	79 405 600	8 (→ 46), 9 (→ 47)
51.02410-6692	79 600 600	8 (→ 46), 9 (→ 47)
51.02410-6698	37 280 600	8 (→ 46), 9 (→ 47)
51.02410-6698	79 405 600	8 (→ 46), 9 (→ 47)
51.02410-6698	79 600 600	8 (→ 46), 9 (→ 47)
51.02410-6700	37 280 610	8 (→ 46), 9 (→ 47)
51.02410-6700	79 405 610	8 (→ 46), 9 (→ 47)
51.02410-6700	79 600 610	8 (→ 46), 9 (→ 47)
51.02410-6701	37 280 620	8 (→ 46), 9 (→ 47)
51.02410-6701	79 405 620	8 (→ 46), 9 (→ 47)
51.02410-6701	79 600 620	8 (→ 46), 9 (→ 47)
51.02410-6767	79 405 600	8 (→ 46), 9 (→ 47)
51.02410-6774	77 879 600	8 (→ 46), 9 (→ 47)
51.02410-6785	79 405 600	8 (→ 46), 9 (→ 47)
51.02500-6046	40 208 600	11 (→ 48), 12 (→ 49), 21 (→ 59), 23 (→ 61)
51.02500-6157	41 000 600	11 (→ 48), 12 (→ 49) ... 23 (→ 61), 24 (→ 63)
51.02500-6232	41 259 600	1 (→ 43), 2 (→ 43), 3 (→ 44), 4 (→ 44)
51.02500-6353	41 260 960	14 (→ 51), 19 (→ 57)
51.02500-6356	41 000 960	11 (→ 48), 12 (→ 49), 13 (→ 50), 24 (→ 63)
51.02500-6363	42 089 600	26 (→ 64), 27 (→ 65), 28 (→ 65), 29 (→ 65)
51.02500-6364	42 090 600	26 (→ 64), 27 (→ 65), 28 (→ 65), 29 (→ 65)
51.02500-6369	42 089 600	26 (→ 64), 27 (→ 65), 28 (→ 65), 29 (→ 65)
51.02500-6372	42 090 600	26 (→ 64), 27 (→ 65), 28 (→ 65), 29 (→ 65)
51.02500-6422	41 259 600	1 (→ 43), 2 (→ 43), 3 (→ 44), 4 (→ 44)
51.02500-6535		
51.02500-6544	42 090 600	26 (→ 64), 27 (→ 65), 28 (→ 65), 29 (→ 65)
51.02500-6554	41 259 600	1 (→ 43), 2 (→ 43), 3 (→ 44), 4 (→ 44)
51.02500-6573		
51.02501-0851	94 943 600	21 (→ 59), 23 (→ 61), 24 (→ 63)
51.02501-0852	94 942 600	21 (→ 59)
51.02501-0868		
51.02501-6089	41 260 600	14 (→ 51), 19 (→ 57)
51.02501-7534	94 942 600	21 (→ 59)
51.02501-7535	94 943 600	21 (→ 59), 23 (→ 61), 24 (→ 63)
51.02503-0661	80 01269 1 0 000	17 (→ 55), 18 (→ 56), 20 (→ 58)
51.02503-0764		
51.02503-0806	80 00300 1 0 000	13 (→ 50), 14 (→ 51), 15 (→ 52), 16 (→ 54), 19 (→ 57)
51.02503-0998	80 01265 1 0 000	26 (→ 64), 28 (→ 65)
51.02503-7002	80 00155 1 0 000	11 (→ 48), 12 (→ 49) ... 22 (→ 60), 23 (→ 61)
51.03100-6140	200802G2840	11 (→ 48), 12 (→ 49) ... 23 (→ 61), 24 (→ 63)
51.03100-6179		
51.03100-6859		
51.03101-6923		
51.03201-0087	81-2536	11 (→ 48), 12 (→ 49) ... 23 (→ 61), 24 (→ 63)
51.03201-0088		
51.03201-0093	81-2537	11 (→ 48), 12 (→ 49) ... 23 (→ 61), 24 (→ 63)
51.03201-0098	81-25104	1 (→ 43), 2 (→ 43) ... 6 (→ 45), 7 (→ 46)
51.03201-0102	81-25102	14 (→ 51), 15 (→ 52) ... 20 (→ 58), 21 (→ 59)
51.03201-0103	81-25107	11 (→ 48), 12 (→ 49) ... 23 (→ 61), 24 (→ 63)
51.03201-0106	81-25105	1 (→ 43), 2 (→ 43) ... 6 (→ 45), 7 (→ 46)

LISTA PORÓWNAWCZA

REF-No.	ITEM No.	Pos (→ )
MAN		
51.03201-0108	81-25101	11 (→ 48), 12 (→ 49) ... 23 (→ 61), 24 (→ 63)
51.03201-0115	81-25106	8 (→ 46), 9 (→ 47)
51.03201-0126		
51.03201-0131	81-25112	25 (→ 64), 26 (→ 64), 28 (→ 65), 29 (→ 65)
51.03201-0136		
51.03201-1034	81-2536	11 (→ 48), 12 (→ 49) ... 23 (→ 61), 24 (→ 63)
51.03201-1035	81-2537	11 (→ 48), 12 (→ 49) ... 23 (→ 61), 24 (→ 63)
51.03201-1037	81-2538	11 (→ 48), 12 (→ 49) ... 23 (→ 61), 24 (→ 63)
51.03201-1077	81-25106	8 (→ 46), 9 (→ 47)
51.03201-1079		
51.03201-1090		
51.03201-1143	81-25112	25 (→ 64), 26 (→ 64), 28 (→ 65), 29 (→ 65)
51.03201-1152		
51.03203-0182	92-25003	
51.03203-0184		
51.03203-0220		
51.03203-0242	92-25002	
51.03203-0267	92-25004	11 (→ 48), 12 (→ 49) ... 23 (→ 61), 24 (→ 63)
51.03203-0269	92-25005	11 (→ 48), 12 (→ 49) ... 23 (→ 61), 24 (→ 63)
51.03203-0311	92-25003	
51.03210-1040	81-2536	11 (→ 48), 12 (→ 49) ... 23 (→ 61), 24 (→ 63)
51.04101-0438	25310	11 (→ 48), 12 (→ 49) ... 23 (→ 61), 24 (→ 63)
51.04101-0439	25311	11 (→ 48), 12 (→ 49) ... 23 (→ 61), 24 (→ 63)
51.04101-0607	25322	25 (→ 64), 26 (→ 64), 29 (→ 65)
51.04101-0637	25323	25 (→ 64), 26 (→ 64), 29 (→ 65)
51.04101-0720	25322	25 (→ 64), 26 (→ 64), 29 (→ 65)
51.04101-0721	25323	25 (→ 64), 26 (→ 64), 29 (→ 65)
51.04101-0750		
51.04104-0023	KK-12H	11 (→ 48), 12 (→ 49) ... 23 (→ 61), 24 (→ 63)
51.04104-0024	KK-10H	12 (→ 49)
51.04104-0034	MK-9H	25 (→ 64), 26 (→ 64), 28 (→ 65), 29 (→ 65)
51.04202-0081	20100225020	17 (→ 55), 18 (→ 56), 20 (→ 58)
51.04202-5034		
51.04202-5036		
51.04401-0787	20100208361	4 (→ 44), 5 (→ 45)
51.04401-6338	201002G2866	14 (→ 51), 15 (→ 52) ... 19 (→ 57), 20 (→ 58)
51.04401-6371	20100208361	4 (→ 44), 5 (→ 45)
51.04401-6391	20100208341	1 (→ 43), 2 (→ 43)
51.04401-6397	20100208361	4 (→ 44), 5 (→ 45)
51.04401-6421	20100208341	1 (→ 43), 2 (→ 43)
51.04410-0118	87 366 600	11 (→ 48), 12 (→ 49) ... 23 (→ 61), 24 (→ 63)
51.04410-0119		
51.04410-0148		
51.04410-0149		
51.05100-6150	20140228000	
51.05100-6188		
51.05100-6189		
51.05100-6191	20140344300	11 (→ 48), 12 (→ 49) ... 23 (→ 61), 24 (→ 63)
51.05100-6215	20140228000	
51.05100-6250	20140228760	14 (→ 51), 15 (→ 52) ... 19 (→ 57), 20 (→ 58)
51.05100-6252		
51.05100-6253	20140344400	11 (→ 48), 12 (→ 49) ... 23 (→ 61), 24 (→ 63)
51.05100-6260	20140228760	14 (→ 51), 15 (→ 52) ... 19 (→ 57), 20 (→ 58)
51.05100-6262		
51.05100-6279	20140228000	
51.05101-6004	20140228761	14 (→ 51), 15 (→ 52), 16 (→ 54), 19 (→ 57)
51.05101-6006		
51.05101-6008		
51.05102-0085	20140208340	1 (→ 43), 2 (→ 43), 6 (→ 45)
51.05102-0101	20140208260	3 (→ 44), 4 (→ 44), 5 (→ 45)
51.05103-0129	20140220660	7 (→ 46), 9 (→ 47)
51.05103-0132		
51.05103-5036		
51.05103-5037	20140226760	9 (→ 47)
51.05103-5038	20140226761	8 (→ 46), 9 (→ 47)
51.05104-0233	20140220660	7 (→ 46), 9 (→ 47)
51.05104-0233	20140226761	8 (→ 46), 9 (→ 47)
51.05104-0234	20140220660	7 (→ 46), 9 (→ 47)
51.05104-0234	20140226761	8 (→ 46), 9 (→ 47)

LISTA PORÓWNAWCZA

REF-No.	ITEM No.	Pos (→ )
MAN		
51.05104-0244	20140226760	9 (→ 47)
51.05104-0245		
51.05104-0246	20140220660	7 (→ 46), 9 (→ 47)
51.05104-0246	20140226761	8 (→ 46), 9 (→ 47)
51.05104-0251	20140220660	7 (→ 46), 9 (→ 47)
51.05104-0251	20140226761	8 (→ 46), 9 (→ 47)
51.05104-0252	20140226760	9 (→ 47)
51.05104-6195	20140208260	3 (→ 44), 4 (→ 44), 5 (→ 45)
51.05104-6196		
51.05104-6197	20140208340	1 (→ 43), 2 (→ 43), 6 (→ 45)
51.05104-6198		
51.05105-0070	20140220660	7 (→ 46), 9 (→ 47)
51.05105-0070	20140226761	8 (→ 46), 9 (→ 47)
51.05105-5000	20140220660	7 (→ 46), 9 (→ 47)
51.05105-5000	20140226761	8 (→ 46), 9 (→ 47)
51.05105-5002	20140226760	9 (→ 47)
51.05207-0010	20140208260	3 (→ 44), 4 (→ 44), 5 (→ 45)
51.05207-0010	20140208340	1 (→ 43), 2 (→ 43), 6 (→ 45)
51.05601-0031	20190225000	17 (→ 55), 18 (→ 56)
51.05601-0047		
51.05601-0060		
51.05601-0068		
51.05601-0106	20190208360	5 (→ 45)
51.05601-0107		
51.05601-0108		
51.05601-0118		
51.05601-0121	20190225000	17 (→ 55), 18 (→ 56)
51.05601-0133	20190228760	17 (→ 55), 18 (→ 56), 20 (→ 58)
51.05601-0138	20190208360	5 (→ 45)
51.05601-0148	20190228760	17 (→ 55), 18 (→ 56), 20 (→ 58)
51.05601-0152	20190208360	5 (→ 45)
51.05601-0166	20190220661	9 (→ 47)
51.05601-0167		
51.05601-0169	20190228420	10 (→ 48), 11 (→ 48) ... 23 (→ 61), 24 (→ 63)
51.05601-0192	20190220661	9 (→ 47)
51.05601-7164	20190228420	10 (→ 48), 11 (→ 48) ... 23 (→ 61), 24 (→ 63)
51.05601-7176	20190220661	9 (→ 47)
51.06500-6426	20160228661	17 (→ 55), 18 (→ 56), 20 (→ 58)
51.06500-6490		
51.06500-6708		
51.06500-9426		
51.08150-0029	7.01268.03.0	18 (→ 56)
51.09413-0004	7.00380.04.0	18 (→ 56)
51.09413-0006		
51.09413-0007	7.00380.11.0	18 (→ 56)
51.09413-0009		
51.09413-0017		
51.09413-0022		
51.09413-6010		
51.09413-6012	7.00380.04.0	18 (→ 56)
51.09413-6036	7.00380.11.0	18 (→ 56)
51.09413-6049		
51.54121-0003	78 709 600	11 (→ 48), 12 (→ 49) ... 23 (→ 61), 24 (→ 63)
51.54121-0004		
51.54121-6001		
51.54210-0141	20050225001	17 (→ 55), 18 (→ 56)
51.90310-0257	20140220660	7 (→ 46), 9 (→ 47)
51.90310-0257	20140226760	9 (→ 47)
51.90310-0257	20140226761	8 (→ 46), 9 (→ 47)
51.93020-0389	36 099 600	8 (→ 46), 9 (→ 47)
51.93020-0405	36 100 600	8 (→ 46), 9 (→ 47)
64.01113-6001	79 234 610	1 (→ 43), 2 (→ 43) ... 6 (→ 45), 7 (→ 46)
64.01113-6002	79 234 620	1 (→ 43), 2 (→ 43) ... 6 (→ 45), 7 (→ 46)
64.01113-6005	79 234 600	1 (→ 43), 2 (→ 43) ... 6 (→ 45), 7 (→ 46)
64.90490-0050	20140220660	7 (→ 46), 9 (→ 47)
64.90490-0050	20140226760	9 (→ 47)
64.90490-0050	20140226761	8 (→ 46), 9 (→ 47)
64.90490-0065	20140220660	7 (→ 46), 9 (→ 47)
64.90490-0065	20140226760	9 (→ 47)

LISTA PORÓWNAWCZA

REF-No.	ITEM No.	Pos (→ )
MAN		
64.90490-0065	20140226761	8 (→ 46), 9 (→ 47)
81.54121-6001	78 709 600	11 (→ 48), 12 (→ 49) ... 23 (→ 61), 24 (→ 63)
81.54121-6002		
93.21014-0030	41 260 600	14 (→ 51), 19 (→ 57)
93.21014-0055	41 791 600	
93.21014-0063		
93.21014-0081	41883600	
93.21014-0082		
93.21114-0061	81-25103	11 (→ 48), 12 (→ 49) ... 23 (→ 61), 24 (→ 63)
93.21167-0040	89 396 120	
MITSUBISHI		
3750403600	829901	1 (→ 67)
MTU		
D93211140061	81-25103	2 (→ 69), 3 (→ 70) ... 8 (→ 74), 9 (→ 75)
D93211140285	81-25113	1 (→ 69), 2 (→ 69) ... 8 (→ 74), 9 (→ 75)
93.21014-0090	42 176 600	7 (→ 73)
SCANIA		
0550480	77 943 600	2 (→ 77)
0550494	79 525 600	3 (→ 77), 4 (→ 78), 5 (→ 78)
10570177	20140712001	1 (→ 77)
1304642	80 00364 1 0 000	1 (→ 77), 2 (→ 77)
1333183	20190714000	4 (→ 78)
1350815	79 279 600	1 (→ 77), 2 (→ 77) ... 5 (→ 78), 6 (→ 79)
1363056	77 710 600	1 (→ 77), 6 (→ 79)
1363056	77 864 600	3 (→ 77), 4 (→ 78), 5 (→ 78)
1382183	89 541 110	1 (→ 77)
1400861	20190714000	4 (→ 78)
1403613	77 943 600	2 (→ 77)
1409268	20090716000	4 (→ 78)
1438752	20100712100	2 (→ 77)
1438755	20100712101	2 (→ 77)
1444618	77 711 600	1 (→ 77)
1444619	79 279 600	1 (→ 77), 2 (→ 77) ... 5 (→ 78), 6 (→ 79)
1447060	20100712100	2 (→ 77)
1447065	20100712101	2 (→ 77)
1448933	20190714000	4 (→ 78)
1449203	77 864 600	3 (→ 77), 4 (→ 78), 5 (→ 78)
1449203	77 864 610	3 (→ 77), 4 (→ 78), 5 (→ 78)
1461895	89 541 110	1 (→ 77)
1465337	77 710 610	1 (→ 77), 6 (→ 79)
1465338	77 710 620	1 (→ 77), 6 (→ 79)
1465409	20090712008	2 (→ 77)
1465419	20090716000	4 (→ 78)
1484492	89 541 110	1 (→ 77)
1487564	20090716000	4 (→ 78)
1487566	20090712008	2 (→ 77)
1487775	89 541 110	1 (→ 77)
1500108	20140709000	3 (→ 77), 4 (→ 78), 5 (→ 78)
1527913	20090712008	2 (→ 77)
1539450	20090716000	4 (→ 78)
1543688	20190714000	4 (→ 78)
1720083	7.00936.02.0	3 (→ 77), 4 (→ 78)
1723174	80 00364 1 1 000	1 (→ 77), 2 (→ 77)
1729991	77 711 600	1 (→ 77)
1729991	79 525 600	3 (→ 77), 4 (→ 78), 5 (→ 78)
1729992	77 943 600	2 (→ 77)
1730312	20140713000	6 (→ 79)
1734508	20100716002	7 (→ 79)
1745175	79 525 600	3 (→ 77), 4 (→ 78), 5 (→ 78)
1747749		
1748794	20100712008	6 (→ 79)
1775233	20050790000	3 (→ 77), 4 (→ 78), 5 (→ 78)
1776466	200907DC130	6 (→ 79)
1777779	77 710 610	1 (→ 77), 6 (→ 79)
1777780	77 710 620	1 (→ 77), 6 (→ 79)
1777780	77 942 620	2 (→ 77)

LISTA PORÓWNAWCZA

REF-No.	ITEM No.	Pos (→ )
SCANIA		
1777781	77 710 630	1 (→ 77), 6 (→ 79)
1778923	20160713001	6 (→ 79)
1779130	77 710 600	1 (→ 77), 6 (→ 79)
1779130	77 864 600	3 (→ 77), 4 (→ 78), 5 (→ 78)
1779130	77 942 600	2 (→ 77)
1785692	77 711 600	1 (→ 77)
1785692	79 525 600	3 (→ 77), 4 (→ 78), 5 (→ 78)
1786249	77 711 610	1 (→ 77)
1786250	77 711 620	1 (→ 77)
1786251	77 711 630	1 (→ 77)
1789555	20160709001	3 (→ 77), 4 (→ 78), 5 (→ 78)
1789726	200607DC130	6 (→ 79)
1798722	80 00364 1 1 000	1 (→ 77), 2 (→ 77)
1805085	20090716000	4 (→ 78)
1850688	89 939 110	3 (→ 77), 4 (→ 78), 5 (→ 78), 6 (→ 79)
1854798	105-35639	1 (→ 77)
1854799		
1860961	20140713000	6 (→ 79)
1865230	20100712008	6 (→ 79)
1868157	89 541 110	1 (→ 77)
1868606	79 525 610	3 (→ 77), 4 (→ 78), 5 (→ 78)
1868607	79 525 620	3 (→ 77), 4 (→ 78), 5 (→ 78)
1884327	20160709001	3 (→ 77), 4 (→ 78), 5 (→ 78)
1886246	105-35639	1 (→ 77)
1886946		
1887056		
1888024	20140709000	3 (→ 77), 4 (→ 78), 5 (→ 78)
1888025	20140712001	1 (→ 77)
1900032	20190714000	4 (→ 78)
1908172	20100716003	7 (→ 79)
1917105	89 939 110	3 (→ 77), 4 (→ 78), 5 (→ 78), 6 (→ 79)
1920163	200607DC130	6 (→ 79)
1929265		
1939481	20160713001	6 (→ 79)
1940008	81-34005	7 (→ 79)
1945965	20190714003	7 (→ 79)
2006210	20160713001	6 (→ 79)
2006397	20160709001	3 (→ 77), 4 (→ 78), 5 (→ 78)
2023341	105-35654	1 (→ 77)
2023345		
2026052		
2028986	20140709000	3 (→ 77), 4 (→ 78), 5 (→ 78)
2028987	20140712001	1 (→ 77)
2037887	92-34008	4 (→ 78), 5 (→ 78), 6 (→ 79)
2040258	92-34009	4 (→ 78), 5 (→ 78), 6 (→ 79)
2043067	89 935 110	6 (→ 79), 7 (→ 79)
2055915	20140709004	3 (→ 77), 4 (→ 78), 5 (→ 78)
2068259	20100716002	7 (→ 79)
2068433	20100716003	7 (→ 79)
2079956	77 710 600	1 (→ 77), 6 (→ 79)
2105497	20140713000	6 (→ 79)
2106275	20140713001	6 (→ 79)
2110655	105-35639	1 (→ 77)
2133515	20050713000	6 (→ 79)
2145520	20050790000	3 (→ 77), 4 (→ 78), 5 (→ 78)
2161493	105-35639	1 (→ 77)
2183352	89 939 110	3 (→ 77), 4 (→ 78), 5 (→ 78), 6 (→ 79)
2190306	200607DC130	6 (→ 79)
2206260	89 939 110	3 (→ 77), 4 (→ 78), 5 (→ 78), 6 (→ 79)
2209508	20140709000	3 (→ 77), 4 (→ 78), 5 (→ 78)
2209509	20140712001	1 (→ 77)
2224045	20160713001	6 (→ 79)
2224112	20160709001	3 (→ 77), 4 (→ 78), 5 (→ 78)
2254875	89 935 110	6 (→ 79), 7 (→ 79)
2263286	200607DC130	6 (→ 79)
2301849	7.12441.12.0	5 (→ 78), 6 (→ 79)
2310611	20160713001	6 (→ 79)
2310615	20160709001	3 (→ 77), 4 (→ 78), 5 (→ 78)

LISTA PORÓWNAWCZA

REF-No.	ITEM No.	Pos (→ )
SCANIA		
2385389	7.05717.06.0	5 (→ 78)
2507706	20050713000	6 (→ 79)
2527395	20050790000	3 (→ 77), 4 (→ 78), 5 (→ 78)
2547925	20140716002	7 (→ 79)
2579258	77 971 600	6 (→ 79)
2686288	20140713000	6 (→ 79)
2793574	20190714000	4 (→ 78)
2819310	81-34006	3 (→ 77), 4 (→ 78), 5 (→ 78), 6 (→ 79), 7 (→ 79)
2827104	81-34005	7 (→ 79)
2985692	77 710 600	1 (→ 77), 6 (→ 79)
550255	80 00364 1 0 000	1 (→ 77), 2 (→ 77)
550494	77 711 600	1 (→ 77)
550495		
550495	77 711 610	1 (→ 77)
550496	77 711 620	1 (→ 77)
550497	77 711 630	1 (→ 77)
570193	20160713001	6 (→ 79)
570194	20160709001	3 (→ 77), 4 (→ 78), 5 (→ 78)
570196	200607DC130	6 (→ 79)
575052	20160709001	3 (→ 77), 4 (→ 78), 5 (→ 78)
575053	20160713001	6 (→ 79)
576662	20160709001	3 (→ 77), 4 (→ 78), 5 (→ 78)
576663	20160713001	6 (→ 79)
576664		
576665	20160709001	3 (→ 77), 4 (→ 78), 5 (→ 78)



TRANSFER WIEDZY

WIEDZA FACHOWA OD EKSPERTA

SZKOLENIA NA CAŁYM ŚWIECIE

Bezpośrednio od producenta

Co roku około 4 500 mechaników i techników korzysta z naszych szkoleń i seminariów, które przeprowadzamy w każdym miejscu na świecie oraz w naszych centrach szkoleniowych w Neuenstadt, Dormagen i Tamm (Niemcy).

INFORMACJE TECHNICZNE

Od praktyków dla praktyków

Dzięki naszym Product Information, Service Information, broszurom technicznym oraz plakatom zawsze jesteś na aktualnym poziomie techniki.

WIDEOKLIPY TECHNICZNE

Wiedza z wideoklipów

W naszych wideoklipach technicznych można znaleźć praktyczne wskazówki montażowe i opisy systemowe naszych produktów.



PREZENTACJA PRODUKTÓW ONLINE

Przejrzyste objaśnienie naszych rozwiązań

Elementy interaktywne, animacje i filmy przekazują cenne informacje na temat naszych produktów związanych z silnikiem.

SKLEP INTERNETOWY

Bezpośredni dostęp do naszych produktów

Składanie zamówień przez całą dobę. Szybkie sprawdzanie dostępności towaru. Rozbudowane wyszukiwanie produktów poprzez silnik, pojazd, wymiary itp.

NOWOŚCI

Regularne informacje pocztą elektroniczną

Zaprenumeruj online nasz bezpłatny biuletyn, a będziesz regularnie otrzymywał informacje na temat nowych produktów, publikacji technicznych i wiele więcej.

INDYWIDUALNE INFORMACJE

Specjalnie dla naszych klientów

Otrzymasz od nas obszerne informacje na temat naszej szerokiej oferty: jak np. spersonalizowane materiały promocyjne, wsparcie sprzedaży, pomoc techniczną i wiele więcej.



TECHNIPEDIA

Informacje techniczne związane z silnikiem

Nasze know-how udostępniamy w dziale Technipedia.

Tutaj znajdziesz wiedzę fachową pochodzącą od ekspertów.

APLIKACJA MOTORSERVICE

Mobilny dostęp do wiedzy technicznej

Tutaj otrzymasz szybko i łatwo najbardziej aktualne informacje oraz materiały na temat naszych produktów.

MEDIA SPOŁECZNOŚCIOWE

Zawsze na bieżąco

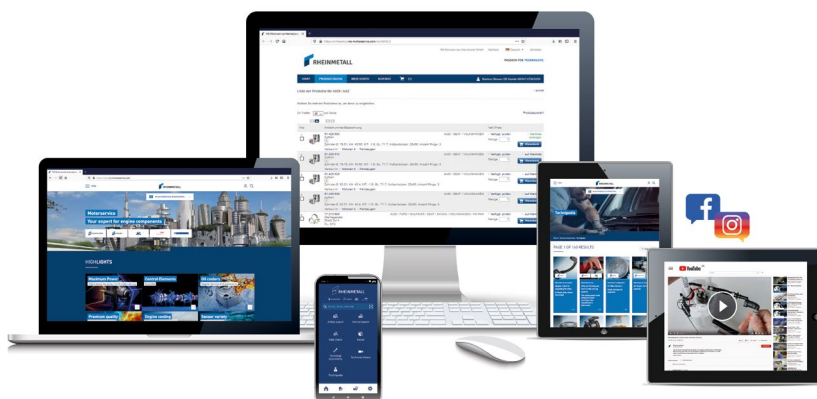

www.ms-motorservice.com



POSTĘPOWANIE W PRZYPADKU ROSZCZEŃ GWARANCYJNYCH

Szanowny Partnerze Biznesowy,
w celu szybkiego i bezproblemowego przetworzenia uprzejmie prosimy o przestrzeganie następujących punktów:

Wymagania dotyczące roszczeń gwarancyjnych

Partner biznesowy firmy Motorservice zapewnia firmę Motorservice, że spełnione są wymagania dotyczące roszczenia gwarancyjnego. Zostało wcześniej sprawdzone, czy reklamowana część pochodzi z programu dostaw Motorservice. Zastrzeżenia do części można zgłaszać tylko w okresie gwarancji.

Zgłoszenie za pośrednictwem sklepu internetowego

Jeśli ma Pan(i) dostęp do sklepu internetowego Motorservice, może Pan(i) wprowadzić zgłoszenie bezpośrednio przez sklep internetowy. W tym celu należy wybrać pozycję „Reklamacje” w menu „Moje konto” i wprowadzić dane w udostępnionym formularzu internetowym.

W zasadzie należy przesłać wszystkie uszkodzone części.

Wskazówka: Wszystkie pozostałe uszkodzone części należy zabezpieczyć do czasu zakończenia roszczeń gwarancyjnych.

Przesłanie roszczeń do MS Motorservice International GmbH

Oszacowanie szkody nie jest możliwe bez przedłożenia części. Roszczenia gwarancyjne dotyczące zużytych części muszą być zawsze wysyłane oddzielnie od zwrotów towarów i reklamacji nowych części do naszego **centrum logistycznego w Neuenstadt (części silnikowe) lub CompetenceCenter Dormagen (Pierburg)** i wyraźnie zadeklarowane (w naszych biurach sprzedaży nie przyjmujemy zwrotów). Transport odbywa się na ryzyko i niebezpieczeństwo klienta. Firma Motorservice nie ponosi odpowiedzialności za reklamowane części, których nie można zdiagnozować ze względu na uszkodzenia transportowe lub które mogą zostać utracone podczas transportu.

Kontrola niszcząca części

W tym kontekście chcielibyśmy zwrócić uwagę, że różne produkty, np. turbosprężarki spalinowe i pompy wodne, muszą być poddane tzw. kontroli niszczącej, aby było możliwe postawienie diagnozy. W tym celu prosimy o wyrażenie zgody poprzez zaznaczenie odpowiedniego pola na załączonym formularzu zgłoszenia gwarancyjnego.

NAJWAŻNIEJSZE INFORMACJE W SKRÓCIE

Zgłoszenie za pośrednictwem sklepu internetowego
„Moje konto” / „Reklamacje”

Adresy do zwrotu części

Części uszkodzone Pierburg:
**MS Motorservice International GmbH
S-CQM
Hamburger Straße 15
41540 Dormagen, Germany**

Części uszkodzone części silnika
**MS Motorservice International GmbH
S-CQM
Wilhelm-Maybach-Straße 14–18
74196 Neuenstadt, Germany**

Osoba kontaktowa

W razie jakichkolwiek pytań prosimy o kontakt z odpowiednią osobą kontaktową z zespołu sprzedaży Motorservice.

Osoba kontaktowa ds. części Pierburg:

Zarządzanie reklamacjami S-CQM
pg-warranties@de.rheinmetall.com

POSTĘPOWANIE W PRZYPADKU REKLAMACJI NOWYCH CZĘŚCI

Szanowny Partnerze Biznesowy,
w celu szybkiego i bezproblemowego przetworzenia, uprzejmie prosimy o przestrzeganie następujących punktów:

Zgłoszenie za pośrednictwem sklepu internetowego

Jeśli ma Pan(i) dostęp do sklepu internetowego Motorservice, może Pan(i) wprowadzić zgłoszenie bezpośrednio przez sklep internetowy. W tym celu należy wybrać pozycję „Reklamacje” w menu „Moje konto” i wprowadzić dane w udostępnionym formularzu internetowym.

Przesłanie do MS International GmbH

- Zwrot towaru w jak najkrótszym czasie po stwierdzeniu wady.
- Bezpłatny zwrot do centrum logistycznego w Neuenstadt (w naszych biurach sprzedaży nie przyjmujemy zwrotów)
- Transport powrotny odbywa się na ryzyko i niebezpieczeństwo klienta. Firma Motorservice nie ponosi odpowiedzialności za ewentualną utratę lub uszkodzenia w transporcie.

NAJWAŻNIEJSZE INFORMACJE W SKRÓCIE

Zgłoszenie za pośrednictwem sklepu internetowego
„Moje konto” / „Reklamacje”

Adresy do zwrotu części

Reklamacje nowych części
MS Motorservice International GmbH
Reklamacja nowej części
Wilhelm-Maybach-Straße 14-18
74196 Neuenstadt, Germany

Osoba kontaktowa

W razie jakichkolwiek pytań prosimy o kontakt z odpowiednią osobą kontaktową z zespołu sprzedaży Motorservice.

1. Zakres obowiązywania

- 1.1** Warunki Sprzedaży i Dostawy firmy MS Motorservice International GmbH (zwanej dalej „Sprzedawcą”) mają wyłączną moc obowiązującą. Nie uznajemy warunków Nabywcy odmiennych lub sprzecznych z naszymi Warunkami Sprzedaży i Dostawy, chyba że Sprzedawca wyraźnie zgodził się na piśmie na obowiązywanie odmiennych warunków. Niższe Warunki Sprzedaży i Dostawy obowiązują również wtedy, gdy Sprzedawca bez zastrzeżeń realizuje dostawy na rzecz Nabywcy, znając warunki Nabywcy sprzeczne lub odmienne od własnych Warunków Sprzedaży i Dostawy.
- 1.2** Oddzielne porozumienia pomiędzy Stronami, odbiegające od niniejszych Warunków Sprzedaży i Dostawy lub je uzupełniające, mają pierwszeństwo. Zostaną one uzupełnione niniejszymi Warunkami Sprzedaży i Dostawy, o ile nie zawarto szczególnych postanowień. Treść takich postanowień będzie regulowana na podstawie pisemnej umowy lub pisemnego potwierdzenia Sprzedawcy.
- 1.3** Warunki Sprzedaży i Dostawy obowiązują również w odniesieniu do wszystkich przyszłych transakcji z Nabywcą. Nabywca akceptuje niniejsze Warunki Sprzedaży i Dostawy przez złożenie zamówienia, najpóźniej jednak przez przyjęcie towaru.
- 1.4** Niższe Warunki Sprzedaży i Dostawy obowiązują tylko wobec przedsiębiorców.

2. Oferta i potwierdzenie zamówienia

- 2.1** Oferty Sprzedawcy są zawsze niewiązące. Jeśli zamówienie Nabywcy zostanie zgodnie z prawem zakwalifikowane jako oferta, zostanie ono uznane za przyjęte tylko wtedy, gdy zostanie potwierdzone na piśmie przez Sprzedawcę w ciągu czterech tygodni. Umowa zostanie zawarta najpóźniej w momencie wysyłki lub powiadomienia o przygotowaniu zamówionych towarów, w przypadku dostawy częściowej w momencie wysyłki pierwszej dostawy.
- 2.2** Zmiany i pozostałe porozumienia są wiążące wyłącznie pod warunkiem, że zostały potwierdzone przez Sprzedawcę na piśmie.
- 2.3** Dokumenty, rysunki, dane wymiarowe i masowe, wzory itp. zawarte w ofertach stanowią wyłącznie informacje przybliżone i nie stanowią określeń właściwości. Sprzedawca jest upoważniony do odstępstwa od opisów w ofercie, jeżeli odchylenia nie mają podstawowej lub zasadniczej natury i nie ograniczają w znacznym stopniu celu umowy.
- 2.4** Jeżeli towary zostaną wytworzone w oparciu o rysunki Nabywcy, to miarodajne są rysunki zatwierdzone przez Kupującego. Odstępstwa od zatwierdzonych rysunków muszą zostać oddzielnie uzgodnione, a Sprzedawca musi otrzymać wynagrodzenie za ewentualne koszty dodatkowe.

3. Prawa ochronne

- 3.1** Sprzedawca zastrzega sobie prawa własności i autorskie do wszystkich ilustracji, rysunków, kalkulacji i pozostałych dokumentów. Bez uzyskania wcześniejszej pisemnej zgody Sprzedawcy nie wolno ich wykorzystywać do celów innych niż podane przez Sprzedawcę ani udostępniać osobom trzecim. Dotyczy to zwłaszcza dokumentów pisemnych, które są określone jako „poufne” lub „tajne”.
- 3.2** Sprzedawca odpowiada wyłącznie za roszczenia, które w przypadku zgodnego z umową wykorzystania towarów wynikają z naruszenia praw ochronnych i zgłoszonych praw ochronnych (praw ochronnych), spośród których co najmniej jedno z praw zostało opublikowane przez Europejski Urząd Patentowy lub w jednym z państw Republika Federalna Niemiec, Francja, Wielka Brytania, Austria, Chiny, Japonia lub USA.
- 3.3** Jeżeli dostawy są realizowane zgodnie z rysunkami lub innymi informacjami Nabywcy i spowoduje to naruszenie praw ochronnych osób trzecich, Nabywca zwołni Sprzedawcę ze wszystkich związanych z tym roszczeń.

4. Zalecenia, informacje i wiadomości

Zalecenia, informacje i wiadomości są niewiązące, jeżeli nie dotyczą samego towaru.

5. Ceny

- 5.1** Wszystkie ceny są cenami netto i obowiązują „ex works” (Incoterms®2020, „EXW”) z wyłączeniem opakowania, frachtu, kosztów wysyłki i gwarancji wartości. Zostanie doliczony ustawowy podatek od wartości dodanej (VAT) według obowiązującej stawki.
- 5.2** Ewentualne nakłady dodatkowe spowodowane życzeniami zmian mogą być naliczane Nabywcy przez Sprzedawcę.
- 5.3** Jeżeli po zawarciu umowy wystąpią zdarzenia, powodujące podroźnienie kosztów własnych Sprzedawcy po stronie zaopatrzenia, produkcji lub wysyłki towarów, to Sprzedawca ma prawo do odpowiedniego podwyższenia ceny.

6. Warunki płatności

- 6.1** Faktury są płatne w terminie do 14 dni od daty wystawienia faktury bez potrąceń. Sprzedawca jest uprawniony, również w ramach trwających umów handlowych, do dokonania dostawy w całości lub w części wyłącznie za zapłatą z góry. Rabat obowiązuje wyłącznie za wyraźnym porozumieniem na piśmie.
- 6.2** Nawet w razie sprzecznego powiązania celowego przez Nabywcę, Sprzedawca ma prawo do zaliczenia płatności każdorazowo na najstarsze zobowiązanie bez tytułu wykonawczego. Jeżeli powstały już koszty lub wystąpiły odsetki, Sprzedawca ma prawo do zaliczenia płatności w pierwszej kolejności na koszty, następnie na odsetki i ostatecznie na świadczenia główne.
- 6.3** Nabywca ma prawo do potrącenia jedynie w zakresie i w przypadku, gdy jego roszczenia stwierdzone są prawomocnym wyrokiem, są bezsporne albo uznane przez Sprzedawcę. Prawo zatrzymania przez Nabywcę jest ograniczone do jego roszczeń z tytułu stosunku umownego.
- 6.4** Sprzedawca jest upoważniony do żądania odsetek za zwłokę w wysokości każdorazowo obowiązującej ustawowej stawki procentowej za zwłokę. Wyraźnie zastrzega się prawo do udokumentowania wyższej szkody wskutek zwłoki.

7. Dostawa, termin dostawy, opóźnienie

- 7.1** Okresy i terminy dostawy są uznawane za wiążące uzgodnione tylko pod warunkiem, że zostały one wyraźnie potwierdzone na piśmie przez Sprzedawcę. Sprzedawca nie jest związany terminem dostawy lub okresem dostawy, jeżeli Nabywca nie wypełni swoich zobowiązań (płatność rat, dostarczenie niezbędnych dokumentów, dostarczenie materiałów do produkcji itp.). Zastrzega się prawo do zarzutu niewykonania umowy.
- 7.2** Terminy dostawy rozpoczynają się najwcześniej w dniu zawarcia umowy na piśmie i wyjaśnienia wszystkich kwestii technicznych.
- 7.3** W przypadku żądania zmiany przez Nabywcę Sprzedający będzie zwolniony z przestrzegania uzgodnionego terminu dostawy lub okresu dostawy. W tym przypadku Strony uzgadniają nowy termin lub okres dostawy.
- 7.4** Jeżeli nie uzgodniono inaczej, termin lub okres dostawy są spełnione, jeżeli Sprzedawca udostępni towary w uzgodnionym miejscu.
- 7.5** Nabywca nie może dochodzić żadnych roszczeń, które nie są oparte na umyślnym działaniu lub rażącym zaniedbaniu ze strony Sprzedawcy. Obowiązuje to również w przypadku innych zakłóceń, w szczególności opóźnienie w dostawie spowodowanych siłą wyższą, sporami pracowniczymi, zamieszkami, epidemiami i/lub pandemią, cyberatakami, środkami urzędowymi, brakiem dostaw ze strony dostawców oraz innymi nieprzewidywalnymi, nieuniknionymi i poważnymi zdarzeniami. W takich przypadkach uzgodniony termin dostawy lub okres dostawy zostanie przesunięty zgodnie z czasem trwania przeszkody w dostawie; Sprzedawca poinformuje o tym Nabywcę i, jeśli to możliwe, poda nowy przewidywany termin dostawy. Odszkodowanie za utraty zysk oraz szkody wskutek przerwania działalności gospodarczej są ograniczone do działania umyślnego.
- 7.6** Jeżeli Nabywca spóźnia się z przyjęciem lub w sposób zawiniony narusza pozostałe obowiązki współdziałania, to jesteśmy uprawnieni do żądania odszkodowania za powstałe w związku z tym szkody, włącznie z ewentualnymi dodatkowymi kosztami. Sprzedawca ma ponadto prawo do wyznaczenia Nabywcy adekwatnego terminu odbioru, a po jego bezskutecznym upływie – do odstąpienia od umowy i żądania odszkodowania w miejsce świadczenia.
- 7.7** Dopuszcza się dostawę częściową w ilości możliwej do realizacji. Dlatego roszczenia Nabywcy ze względu na dostawę częściową lub opóźnioną dostawę pozostałej ilości są wykluczone.

8. Zastrzeżenie własności

- 8.1** Sprzedawca zastrzega sobie własność wszystkich dostarczonych towarów aż do chwili otrzymania wszystkich płatności wynikających ze stosunku dostawy, włącznie z zobowiązaniami powstałymi w przyszłości. W przypadku niezgodnego z umową postępowania Nabywcy, zwłaszcza w przypadku zwłoki płatności, Sprzedawca jest uprawniony do żądania zwrotu towarów.
- 8.2** Nabywca zobowiązany jest do ostrożnego obchodzenia się z towarami, a w okresie obowiązywania zastrzeżenia własności jest on zobowiązany do ich wystarczającego ubezpieczenia na własny koszt w wysokości równej cenie zakupu od każdej postaci zniszczenia bądź utraty. Sprzedawca pozostaje uprawniony do ubezpieczenia towarów we własnym zakresie na koszt Nabywcy.
- 8.3** W przypadku zajęć lub innych ingerencji osób trzecich Nabywca musi niezwłocznie poinformować Sprzedawcę o tym na piśmie, aby Sprzedawca mógł wycofać powództwo interwencyjne lub podjąć inne środki prawne. O ile osoba trzecia nie zwróci powstałych w związku z tym kosztów sądowych lub pozasądowych, to odpowiada za nie Nabywca.
- 8.4** Nabywca jest uprawniony do sprzedania zakupionych towarów w toku zwykłej działalności gospodarczej, jednakże już teraz ceduje na Sprzedawcę wszystkie należności w wysokości końcowej faktury VAT (włącznie z ustawowym podatkiem VAT), które przysługują mu od jego odbiorców lub osób trzecich z odpłatnością, a mianowicie niezależnie od tego, czy towary zostały odsprzedane bez lub po przetworzeniu. Do ściągania tej należności Nabywca pozostaje upoważniony również po tej cesji. Nie narusza to uprawnień Sprzedawcy do ściągania tej należności samemu.
- 8.5** Jeżeli zakupione towary zostaną zmieszane lub połączone nierozdzielnie z innymi przedmiotami, nienależącymi do Sprzedawcy, to Sprzedawca nabywa prawo współwłasności nowej rzeczy w stosunku wartości zakupionej rzeczy (końcowa kwota na fakturze, włącznie z podatkiem VAT) do innych zmieszanych przedmiotów w chwili zmieszania lub połączenia. Kupujący będzie nieodpłatnie przechowywał dla Sprzedawcy powstałą w ten sposób własność wyłączną lub współwłasność.

8.6 Jeśli wartość istniejących zabezpieczeń przekracza wartość należności Sprzedawcy łącznie o ponad 20%, to Sprzedawca na żądanie Nabywcy jest zobowiązany do zwolnienia nadmiarowych zabezpieczeń według własnego uznania.

8.7 Jeżeli wiążący porządek prawny nie dopuszcza zastrzeżenia własności, to w przypadku korzystania z kredytu towarowego Sprzedawca i Nabywca udostępniają inne zabezpieczenia.

9. Wysyłka, przeniesienie ryzyka

- 9.1** Wysyłka odbywa się na ryzyko Nabywcy. Ryzyko przechodzi na Nabywcę najpóźniej w chwili wysyłki towarów, nawet jeżeli Sprzedawca świadczy dalsze usługi.
- 9.2** Jeżeli wysyłka opóźnia się wskutek okoliczności, za które Sprzedawca nie ponosi odpowiedzialności, to ryzyko przechodzi na Nabywcę z dniem zgłoszenia gotowości do wysyłki przez Sprzedawcę. Na piśmie żądanie Nabywcy Sprzedawca ubezpieczy przesyłkę na koszt Nabywcy od zniszczenia, szkód powstałych wskutek transportu, pożaru lub wady.
- 9.3** Opakowania transportowe i wszystkie inne opakowania zgodnie z ustawą o opakowaniach nie będą odbierane, z wyjątkiem palet. Nabywca jest zobowiązany do zapewnienia utylizacji opakowania na własny koszt.

10. Środki produkcji

- 10.1** Jeżeli Nabywca udostępnia Sprzedawcy środki produkcji (np. narzędzia, formy), to muszą one zostać wysłane do Sprzedawcy bezpłatnie. Za ich utratę, pogorszenie stanu lub niekompletną dostawę zwrotną i wszelkie wynikające z tego szkody Sprzedawca ponosi odpowiedzialność tylko w przypadku rażącego zaniedbania lub umyślnego działania. Nie obowiązują to w przypadku występowania ustawowego obowiązku przejęcia odpowiedzialności.
- 10.2** Jeżeli środki produkcji są wytwarzane lub nabywane przez Sprzedawcę w imieniu Nabywcy, Sprzedawca wystawi Nabywcy odrębną fakturę uwzględniając poniesione z tego tytułu koszty. Środki produkcji pozostają własnością Sprzedawcy. Sprzedawca nie jest zobowiązany do wydania ich Nabywcy. To samo dotyczy narzędzi następných. Nie narusza to postanowień poniższego punktu 10.3.
- 10.3** W przypadku amortyzacji kosztów środków produkcji poprzez cenę części, w razie niezamortyzowania się narzędzia Nabywca przejmuje niepokryte koszty włącznie z kosztami pozostałych elementów wyposażenia związanych z danym typem. Koszty modeli są zawsze w całości naliczane Nabywcy.
- 10.4** Rysunki i dokumenty przekazane Nabywcy przez Sprzedawcę oraz propozycje Sprzedawcy w zakresie konstrukcji i produkcji towarów nie mogą być ujawniane osobom trzecim, a Sprzedawca może w każdej chwili żądać ich zwrotu.

11. Odpowiedzialność za wady i odpowiedzialność

- 11.1** Sprzedawca nie odpowiada za szkody spowodowane przez naruszenie przepisów w zakresie obsługi, konserwacji i montażu, wykorzystania w niewłaściwy sposób, niezgodnie z przeznaczeniem lub nieodpowiednio, nieprawidłowy lub niestaranny sposób obchodzenia się, naturalne zużycie, niewłaściwe składowanie lub zmiany towaru dokonane przez Nabywcę bądź osoby trzecie. Nabywca lub osoby trzecie mogą zlecać montaż towarów wyłącznie przeszkolonemu i wykwalifikowanemu personelowi.
- 11.2** Sprzedawca ma prawo do wyboru pomiędzy naprawą lub ponową dostawą. Nabywca przekaże wadliwe towary Sprzedawcy w celu ich sprawdzenia na jego żądanie. W przypadku poniesienia przez Sprzedawcę kosztów w związku z nieuzasadnionym żądaniem Nabywcy usunięcia wady (w szczególności kosztów kontroli i transportu) Sprzedawca może żądać zwrotu tych kosztów.
- 11.3** Nakłady niezbędne do działań naprawczych nie są ponoszone przez Sprzedawcę, jeżeli nakłady te ulegną zwiększeniu wskutek faktu przeniesienia towarów w miejsce inne niż pierwotne miejsce ich dostawy.
- 11.4** Jeżeli Nabywca wystąpi z roszczeniem regresowym przeciwko Sprzedawcy po tym, jak sam kupujący zostanie pociągnięty do odpowiedzialności za wady przez swojego klienta, do egzekwowania praw stosuje się § 445a niemieckiego kodeksu cywilnego (BGB).
- 11.5** Roszczenia z tytułu odpowiedzialności za wady ulegają przedawnieniu po upływie jednego roku od chwili przekazania towaru, chyba że roszczenia z tytułu odpowiedzialności za wady wynikają z rażąco niedbałego lub umyślnego naruszenia obowiązków przez Sprzedawcę lub przez osoby wykonujące jego zobowiązania bądź z uszczerbku na zdrowiu, obrażeń ciała albo utraty życia. W przypadku roszczeń z tytułu rekojmi za wady, których Nabywca dochodzi od Sprzedawcy w drodze regresu zgodnie z § 445a BGB, przepis o przedawnieniu § 445b BGB ma zastosowanie bez ograniczeń.
- 11.6** Nabywca jest zobowiązany do spełnienia swojego obowiązku badania zgodnie z § 377 niemieckiego kodeksu handlowego również w przypadku odsprzedaży towarów.
- 11.7** Prawo Nabywcy do roszczeń zwrotnych wobec Sprzedawcy ze względu na takie roszczenia z tytułu odpowiedzialności za wady, które są wnoszone przeciwko Nabywcy przez jego odbiorców, pozostaje wykluczone, jeżeli Nabywca nie spełni swojego obowiązku badania i upominania albo jeżeli towar został zmieniony przez dalsze przetwarzanie.
- 11.8** Odpowiedzialność Sprzedawcy w zakresie odszkodowania zgodnie z wymaganiami ustawowymi pozostaje nieograniczona, jeżeli naruszenie obowiązków po stronie Sprzedawcy jest wynikiem umyślnego działania lub rażącego zaniedbania. Jeżeli naruszenia obowiązków leżące w zakresie Sprzedawcy wynikają ze zwykłej niedbałości przy jednoczesnym zawinionym naruszeniu jednego z ważnych obowiązków umownych, odpowiedzialność odszkodowawcza jest ograniczona do przewidywalnej szkody występującej w porównywalnych przypadkach. W pozostałym zakresie odpowiedzialność jest wykluczona.
- 11.9** Odszkodowanie za utratę zysku i szkody spowodowane przerwaniem działalności jest ograniczone do umyślnego działania i rażącego niedbalstwa.
- 11.10** Odpowiedzialność zgodnie z przepisami ustawy o odpowiedzialności za produkt lub porównywalnymi, niezbędnymi prawami, w tym zagranicznymi systemami prawnymi, pozostaje nienaruszona. Nie narusza to ponadto odpowiedzialności ze względu na uszczerbek na zdrowiu, obrażenia ciała lub utratę życia.
- 11.11** O ile odpowiedzialność jest wynikiem stanu faktycznego zgodnie z punktem 11.9, odpowiedzialność Sprzedawcy wobec Nabywcy w przypadku zagranicznych porządków prawnych jest ograniczona na tyle, na ile jest to dopuszczalne prawem zagranicznym.
- 11.12** O ile odpowiedzialność odszkodowawcza Sprzedawcy jest wykluczona lub ograniczona, dotyczy to również osobistej odpowiedzialności odszkodowawczej pracowników, przedstawicieli i osób wykonujących zobowiązania Sprzedawcy.

12. Zakaz cesji

- 12.1** Żadne roszczenia Nabywcy wobec Sprzedawcy nie mogą podlegać cesji.
- 12.2** Sprzedawca ma prawo w każdej chwili, nawet bez zgody Nabywcy, zaangażować w szczególności spółki z nim powiązane (w rozumieniu § 15 niemieckiej ustawy o spółkach akcyjnych (AktG)) jako pomoc w przygotowaniu oferty i wykonaniu umowy.

13. Odpowiedzialność za produkt, obowiązki informowania

- 13.1** Nabywca może użytkować towary tylko zgodnie z przeznaczeniem i musi zadbać o to, aby towary były odsprzedawane wyłącznie osobom zapoznanym z zagrożeniami i ryzykiem powodowanym przez produkty.
- 13.2** W przypadku wykorzystania towarów jako materiału wsadowy i półproduktu do własnych produktów Nabywca przy wprowadzaniu produktu końcowego na rynek jest zobowiązany do spełnienia obowiązków na nim obowiązujących ostrzeżenia także w odniesieniu do towarów dostarczonych przez Sprzedawcę. W stosunkach krajowych Nabywca na pierwsze żądanie zwalnia Sprzedawcę z dochodzenia roszczeń w przypadku naruszenia tego obowiązku.

14. Poufność

Nabywca musi traktować wszystkie otrzymane od Sprzedawcy informacje handlowe i techniczne jako tajemnice handlowe i tajemnice przedsiębiorstwa, jeśli nie są one ogólnie znane. Tego rodzaju informacje mogą być przekazywane osobom trzecim wyłącznie do celów związanych z umową pod warunkiem objęcia tych osób odpowiednim porozumieniem o zachowaniu poufności.

15. Ochrona danych

Sprzedawca gromadzi, przetwarza i wykorzystuje dane osobowe Nabywcy wyłącznie zgodnie z odpowiednimi przepisami o ochronie danych. W związku z tym dane osobowe Nabywcy będą wykorzystywane wyłącznie w przypadku uzyskania prawnego zezwolenia lub zgody.

16. Pozostałe

- 16.1** Miejsce wykonania jest lokalizacją danego zakładu Sprzedawcy.
- 16.2** Wszystkie spory wynikające z niniejszej umowy lub związane z nią będą rozstrzygane przez sąd w Heilbronn. Sprzedawca ma ponadto prawo do wniesienia powództwa przeciwko Nabywcy w sądzie właściwym miejscowo dla niego.
- 16.3** W odniesieniu do realizacji umów na bazie niniejszych Warunków Sprzedaży i Dostawy obowiązują wyłącznie niemieckie prawo państwa z wyłączeniem międzynarodowego prawa prywatnego oraz prawa handlowego ONZ (CISG).
- 16.4** W ramach realizacji stosunków umownych Strony zobowiązane są do przestrzegania wszystkich wymagań ustawowych.
- 16.5** Jeżeli jedno lub kilka powyższych postanowień okazało się bezskuteczne w części lub w całości, to nie narusza to skuteczności pozostałych postanowień. Nieważne postanowienie musi zostać zastąpione przez ustawowo dopuszczalne postanowienie, pozwalające na osiągnięcie sensu i celu niniejszych Warunków Sprzedaży i Dostawy w możliwie taki sam sposób.

HEADQUARTERS:

MS Motorservice International GmbH

Wilhelm-Maybach-Straße 14–18

74196 Neuenstadt, Germany

www.ms-motorservice.com



www.rheinmetall.com

© MS Motorservice International GmbH – BR 2035-13 – PL – 11/23 (072025)